



integration with integrity

User's Manual

Single Board Computer 3308870

Version 1.0 March 2009

---

---

## **Copyrights**

This manual is copyrighted and all rights are reserved. It does not allow any non authorization in copied, photocopied, translated or reproduced to any electronic or machine readable form in whole or in part without prior written consent from the manufacturer.

In general, the manufacturer will not be liable for any direct, indirect, special, incidental or consequential damages arising from the use of inability to use the product or documentation, even if advised of the possibility of such damages. The manufacturer keeps the rights in the subject to change the contents of this manual without prior notices in order to improve the function design, performance, quality and reliability. The author assumes no responsibility for any errors or omissions, which may appear in this manual, nor does it make a commitment to update the information contained herein.

## **Trademarks**

Intel is a registered trademark of Intel Corporation.

Award is a registered trademark of Award Software, Inc.

All other trademarks, products and or product's name mentioned herein are mentioned for identification purposes only, and may be trademarks and/or registered trademarks of their respective companies or owners.

---

---

## Packing List:

Please check the package content before you starting using the board.

### Hardware:

3308870 Half-size PCI CPU Card x 1

### Cable Kit:



SATA Cable x 2



4-pin to 3-pin ATX cable x 1



PS2 Keyboard / Mouse Y-cable x 1

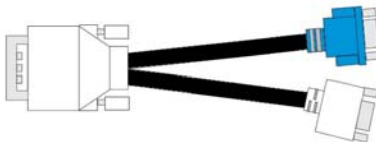

DVI VGA Cable x 1

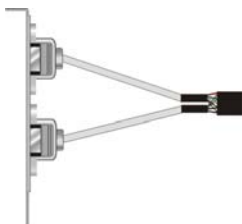

USB Cable x 1

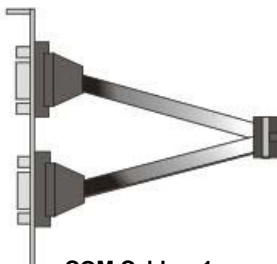

COM Cable x 1



CPU Cooler x 1

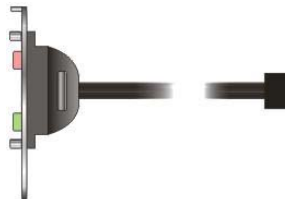

AUDIO Cable x 1



YPbPr Cable (Optional)

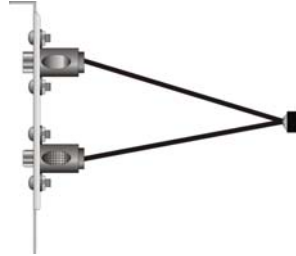

SDTV Cable (Optional)

## Printed Matters:

Driver CD x 1 (Including User's Manual)

---

---

# Chapter 1 <Introduction>

## 1.1 <Product Overview>

**3308870**the new generation of the Half-size PCI CPU Card, supports Intel Penryn Processor for 667/800/1066 MHz front side bus and features Intel GM45 and ICH9M chipset, integrated GMA 4500MHD graphics up to 1024MB shared with system memory, DDR3 memory, REALTEK High Definition Audio, Serial ATA and two Intel Gigabit LAN.

### Intel Penryn Processor

The board supports Intel Penryn Processors with 667/800/1066 MHz front side bus, 6MB L2 cache, to provide more powerful performance than before.

### New features for Intel GM45 chipset

The board integrates Intel GM45 and ICH9M chipset, to provide new generation of the mobile solution, supports Intel GMA 4500MHD graphics up to 1024MB shared with system memory, DDR3 800/1066 MHz memory, built-in high speed mass storage interface of serial ATA, High Definition Audio with 2 channels surrounding sound.

### All in One multimedia solution

Based on Intel GM45 and ICH9M chipset, the board provides high performance onboard graphics, 18/24-bit dual channel LVDS interface, DVI, HDTV and 2 channels High Definition Audio, to meet the very requirement of the multimedia application.

### Flexible Extension Interface

The board provides one mini-PCI socket and one PCI Express Mini card.

---

---

## 1.2 <Product Specification>

Form Factor	Half-size PCI Bus CPU Card
CPU	Support Intel Penryn Processor Package type: <b>Micro-FCPGA478 (Socket-P)</b> Front side bus: 667/800/1066 MHz
Memory	2 x DDRIII SO-DIMM 800/1066 up to 4GB
Chipset	Intel GM45 & ICH9M
Real Time Clock	Chipset integrated RTC with onboard lithium battery
Watchdog Timer	Generates a system reset with internal timer for 1min/s ~255min/s
Power Management	ACPI 2.0 compliant, supports power saving mode
Serial ATA Interface	4 x serial ATAI interface with 300MB/s transfer rate
VGA Interface	Intel integrated extreme GMA 4500MHD (Graphic Media Accelerator) Technology
Video Memory	Up to 1024MB shared with system memory
LVDS interface	Onboard 18/24-bit dual channel LVDS connector with +3.3V/+5V/+12V supply
Audio Interface	Intel integrated ICH9M with Realtek HD Audio codec
LAN Interface	2 x Intel 82574L Gigabit Ethernet
GPIO interface	Onboard programmable 8-bit Digital I/O interface
Extended Interface	1 x PCI express Mini card and 1 x Mini PCI socket
Internal I/O Port	1 x RS232/422/485, 1 x RS232, 1 x ATKB, 1 x SMBUS, 1 x GPIO, 1 x HDTV, 8 x USB ports, 1 x IrDA, 1 x LVDS, 4 x Serial ATA, 1 x LCD inverter, 1 x Front panel Audio, 1 x CDIN and 1 x VGA
External I/O Port	2 x RJ45 LAN ports, 1 x DVI-I port and 1 x PS/2 Keyboard/Mouse Port
Power Requirement	DC 5V/12V power required, optional 5VSB for ATX Onboard 4-pin power connector & 3-pin ATX connector
Dimension	185mm x 122mm (L x W)
Temperature	Operating within 0~60 centigrade Storage within -20~85 centigrade

---

### 1.3 <Mechanical Drawing>

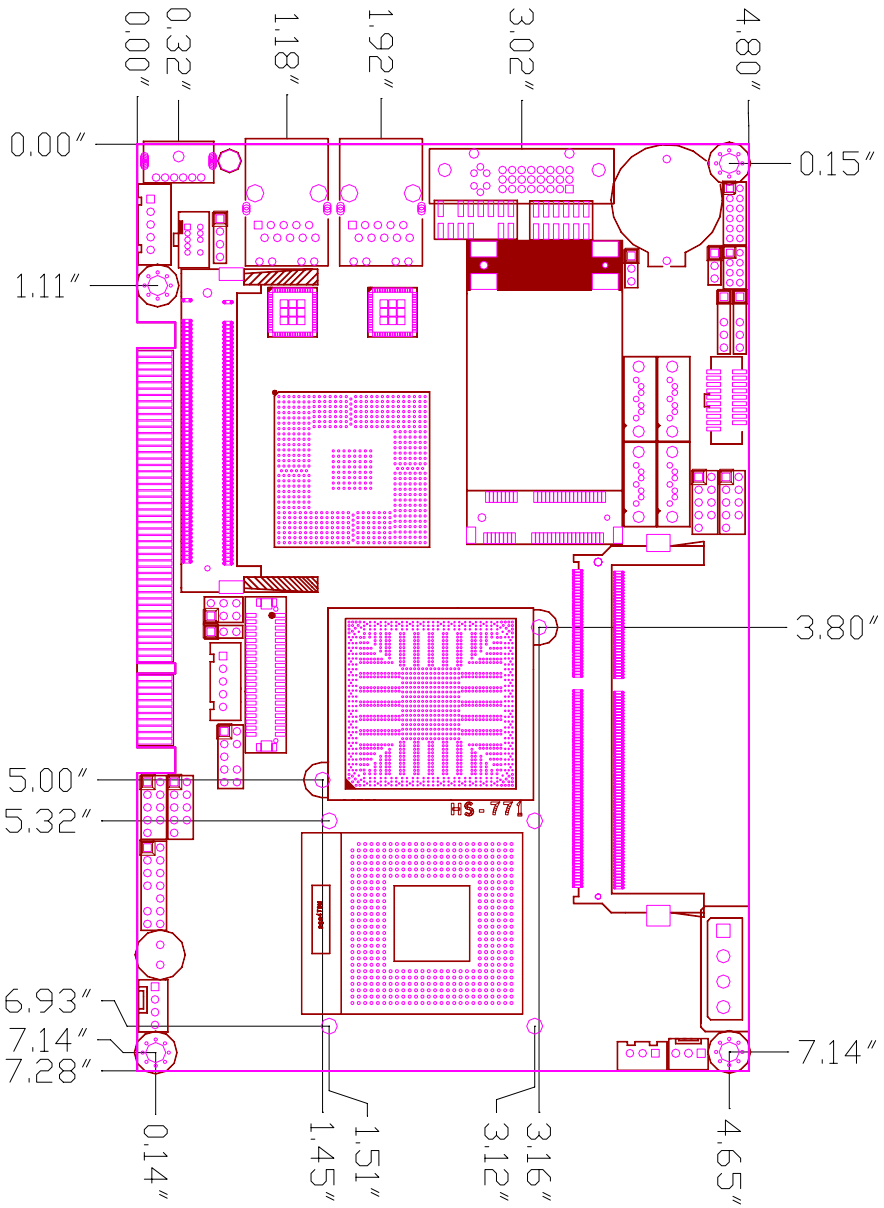

## 1.4 <Block Diagram>

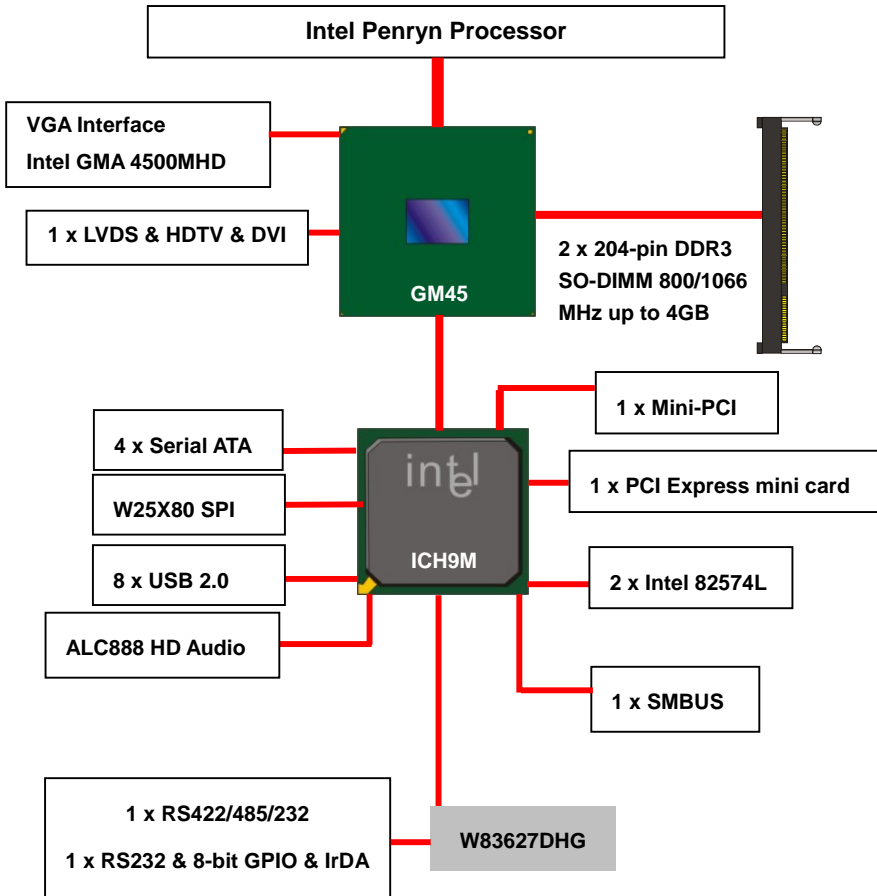

# Chapter 2 <Hardware Setup>

## 2.1 <Connector Location>

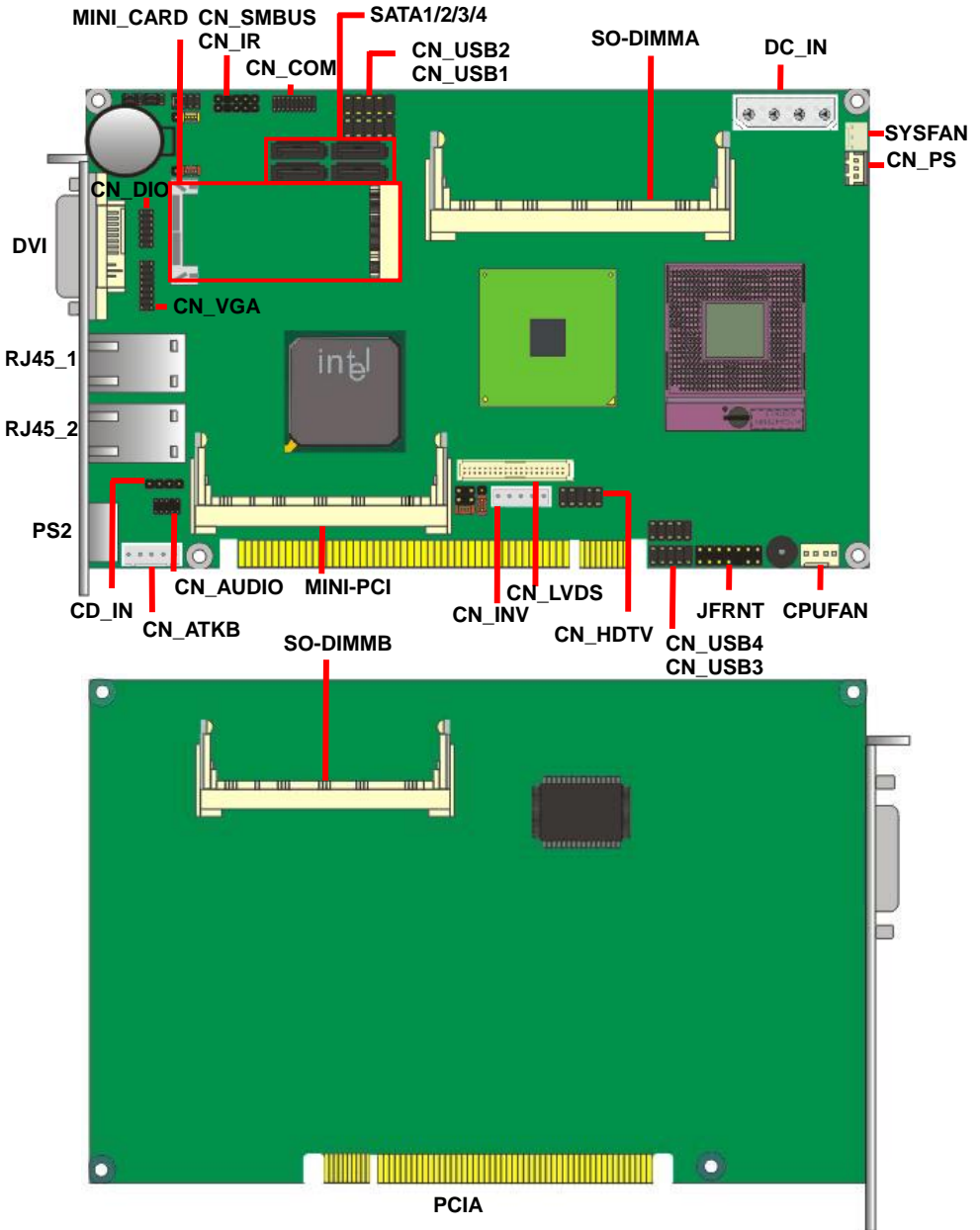

## 2.2 <Jumper Location & Reference>

Jumper	Function
JRTC	CMOS Operating/Clear Setting
JAT	AT/ATX Mode Setting
JVLCD	Panel Voltage Setting
JVINV	Inverter Voltage Setting
JCSEL1	Com2 RS-232/RS-422/RS-485/IR Setting
JCSEL2	Com2 RS-232/RS-422/RS-485/IR Setting

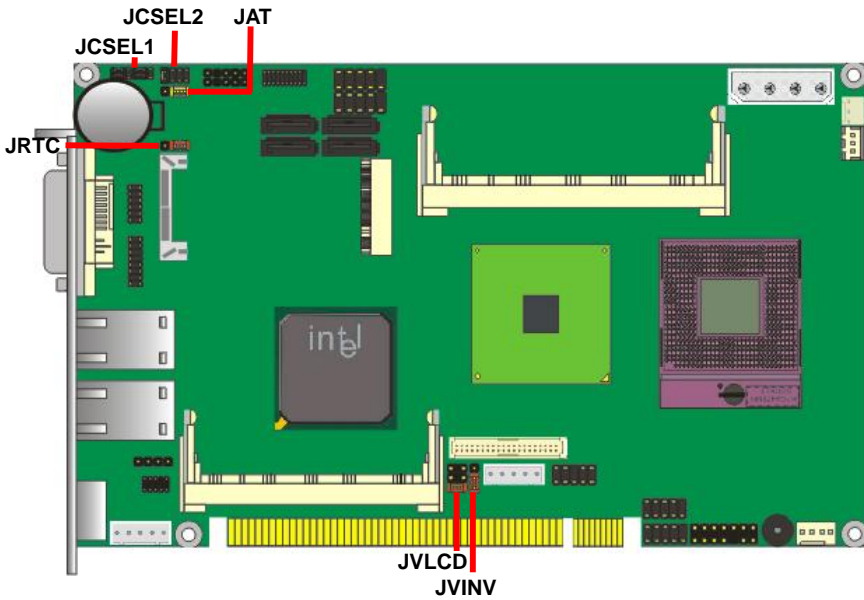

## 2.2.1 <CMOS Setup>

The board's data of CMOS can be setting in BIOS. If the board refuses to boot due to inappropriate CMOS settings, here is how to proceed to clear (reset) the CMOS to its default values.

**Jumper: JRTC**



**Type: Onboard 3-pin jumper**

JRTC	Mode
1-2	Clear CMOS
2-3	Normal Operation

Default setting: 2-3

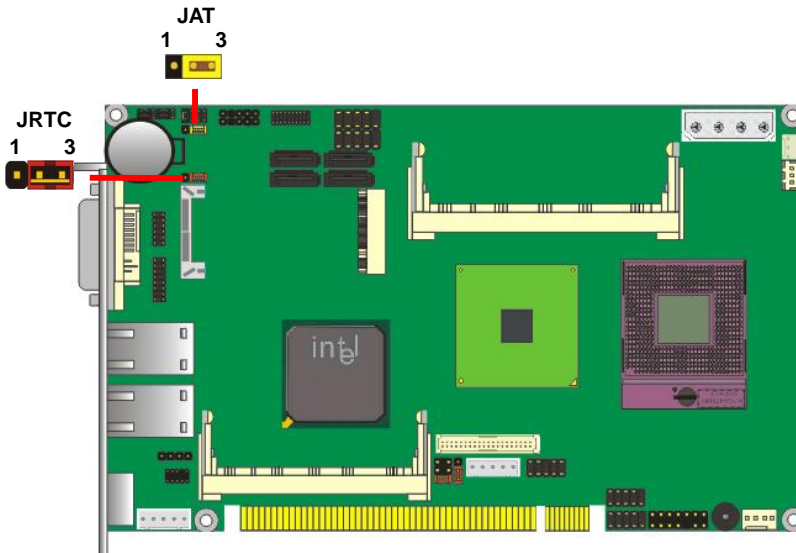

## 2.2.2 <JAT Setup>

**Jumper: JAT**



**Type: Onboard 3-pin jumper**

JRTC	Mode
1-2	AT Mode
2-3	ATX Mode

Default setting: 2-3

---

## 2.3 <Connector Reference>

### 2.3.1 <Internal Connectors>

Connector	Function	Remark
CPU	Socket478 for <b>socket-P</b> CPU	
SO-DIMMA/B	204 -pin DDR3 SO-DIMM socket	
SATA1/2/3/4	7-pin Serial ATA connector	
DC_IN	4-pin power supply connector	
CN_AUDIO	5 x 2-pin audio connector	
CD_IN	4-pin CD-ROM audio input connector	
CN_DIO	6 x 2-pin digital I/O connector	
CN_USB1/2/3/4	5 x 2-pin USB connector	
CPUFAN	4-pin CPU cooler fan connector	
SYSFAN	3-pin system cooler fan connector	
CN_HDTV	5 x 2-pin HDTV interface	
CN_LVDS	20 x 2-pin LVDS connector	
CN_INV	5-pin LCD inverter connector	
CN_IR	5-pin IrDA connector	
CN_SMBUS	5-pin SMBUS connector	
CN_PS	3-pin ATX function connector	
CN_INV	5-pin LCD inverter connector	
CN_ATKB	5-pin AT keyboard connector	
JFRNT	14-pin front panel switch/indicator connector	
Mini-PCI	124-pin Mini-PCI socket Type IIIA	
PCIE Mini card	52-pin PCIE Mini card	
CN_COM	20-pin RS232 & RS422/485/232 connector	

### 2.3.2 <External Connectors>

Connector	Function	Remark
DVI	DVI Digital VGA connector	
RJ45_1/2	RJ45 LAN connector	
PS/2	PS/2 keyboard and mouse connector	

---

---

## 2.4 <CPU and Memory Setup>

### 2.4.1 <CPU Setup>

The board comes with the socket478 for Intel Penryn **socket-P** Processor 667/800/1066 MHz of front side bus and 6MB L2 cache. Please follow the instruction to install the CPU properly.

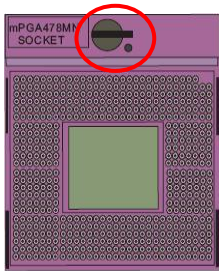

1. Use the flat-type screw drive to unlock the CPU socket

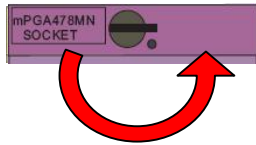

Unlock way

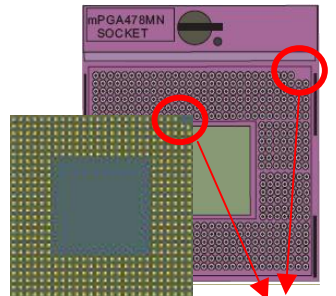

Check point

2. Follow the pin direction to install the processor on the socket

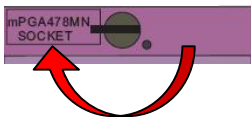

3. Lock the socket

4. Socket P has 478 pins, but is not pin-compatible with Socket M CPU.

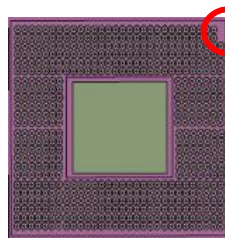

Socket-M CPU  
Check point

---

## 2.4.2 <Memory Setup>

It has two 204-pin DDR3 SO-DIMM supports up to 4GB of memory capacity. The memory frequency supports 800/1066MHz. Only Non-ECC memory is supported. Dual-Channel technology is supported while applying two same modules on one of each group.

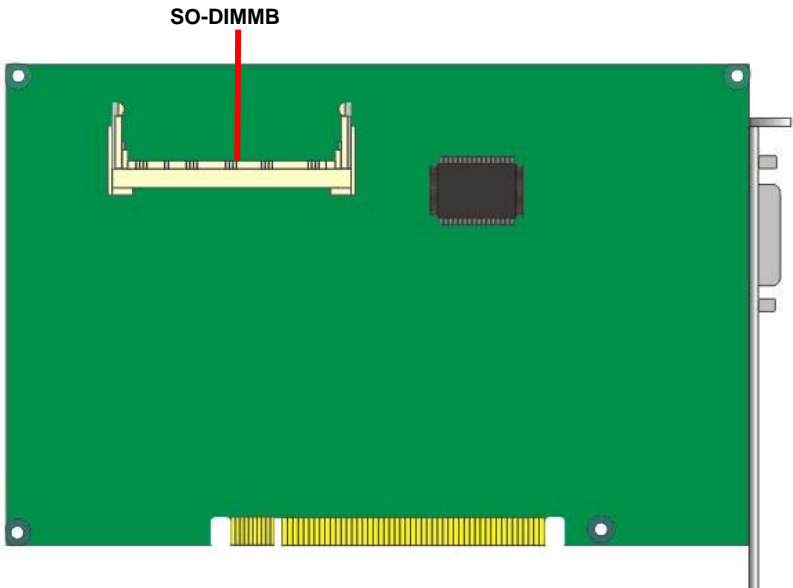
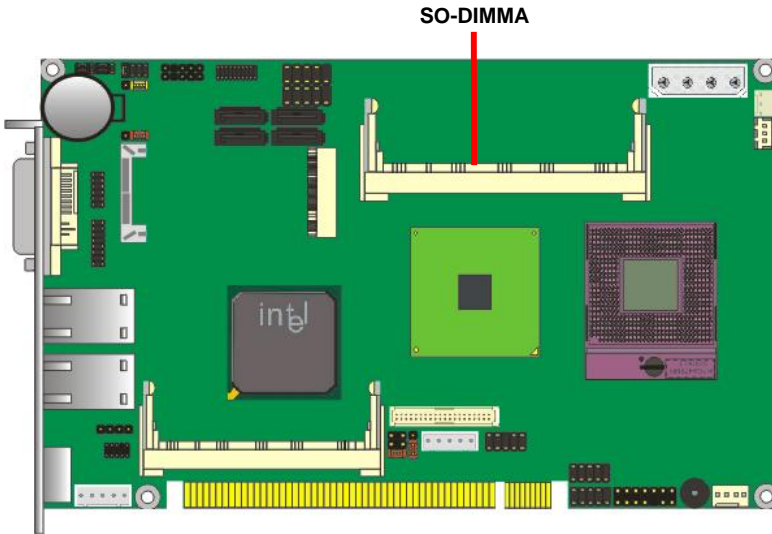

## 2.5 <Serial ATA Interface>

Based on Intel ICH9M, the board provides four Serial ATA interfaces with up to 300MB/s of transfer rate.

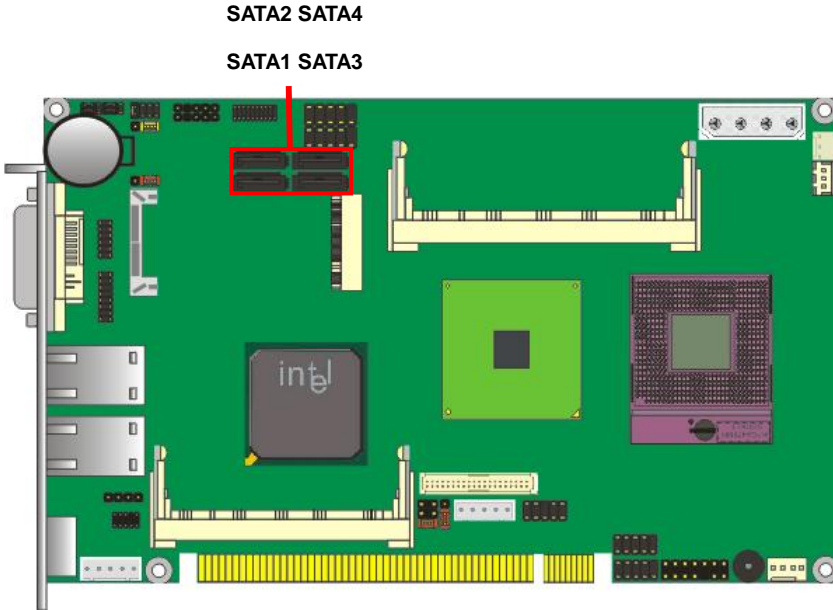

Connector: **SATA1/2/3/4**

Type: 7-pin wafer connector

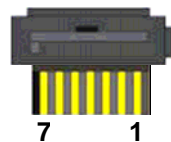

1	2	3	4	5	6	7
GND	SATA_TXP0	SATA_TXN0	GND	SATA_RXN0	SATA_RXP0	GND

## 2.6 <Ethernet Interface>

The board integrates with two Intel PCI Express Gigabit Ethernet controllers, as the PCI Express x1 can speed up to 250MB/s of transfer rate instead of late PCI bus with 133MB/s of transfer rate. The Intel Gigabit Ethernet supports triple speed of 10/100/1000Base-T, with IEEE802.3 compliance and Wake-On-LAN supported.

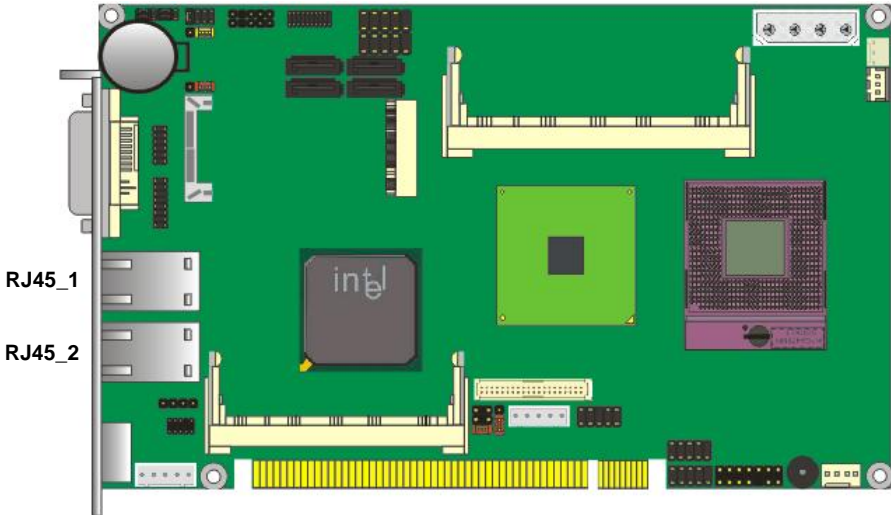

### 2.6.1 <LAN Port>

Connector: **RJ45\_1/2**

Type: RJ45 connector with LED



Pin	1	2	3	4	5	6	7	8
Description	MI0+	MI0-	MI1+	MI2+	MI2-	MI1-	MI3+	MI3-

## 2.7 <Onboard Display Interface>

Based on Intel GM45 chipset with built-in GMA (Graphic Media Accelerator) 4500MHD graphics up to 1024MB shared with system memory, the board provides one DB15 on DVI-I real external DVI VGA cable, one 40-pin LVDS interface with 5-pin LCD backlight inverter connector and one DVI-I on bracket. The board provides dual display function with clone mode and extended desktop mode for VGA, LVDS and HDTV.

### 2.7.1 <Analog Display>

Please connect your CRT or LCD monitor with DB15 to the DVI VGA cable DB15 female connector on rear I/O port.

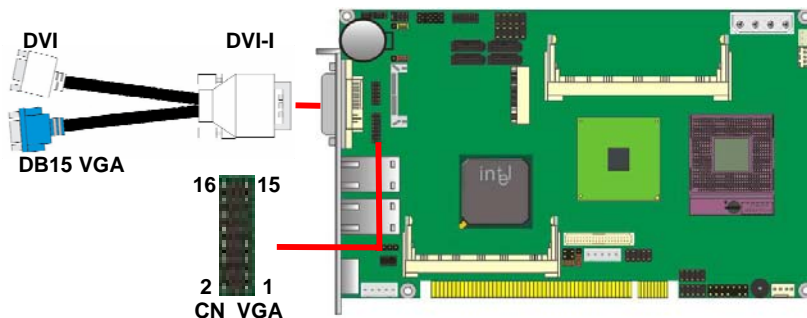

Connector: **CN\_VGA**

Type: onboard 16-pin connector for CN\_VGA connector pitch 2.00mm

Pin	Signal	Pin	Signal
1	BR	2	BG
3	BB	4	NC
5	-CRTATCH	6	VGAGND
7	-CRTATCH	8	VGAGND
9	NC	10	VGAGND
11	NC	12	5VCDA
13	5HSYNC	14	5VSYNC
15	5VCLK	16	NC

## 2.7.2 <Digital Display>

The board provides DVI external connector and one 40-pin LVDS connector for 18/24-bit dual channel panels, supports up to 1920 x 1200 (UXGA) resolution, with one LCD backlight inverter connector and one jumper for panel voltage setting.

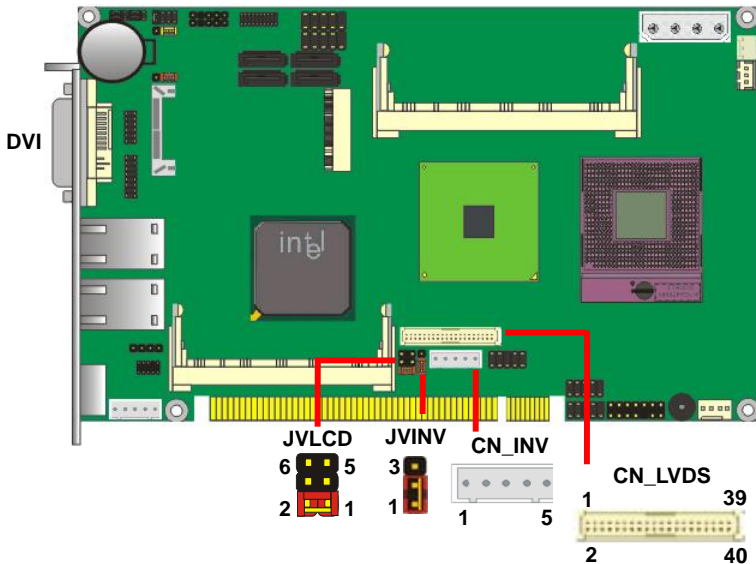

**Effective patterns of connection: 1-2 / 3-4 / 5-6**



**Warning: others cause damages**

Connector: **CN\_INV**

Type: 5-pin LVDS Power Header

Pin	Description
1	INV_VCC
2	N/C
3	GND
4	GND
5	ENABKL

Connector: **JVINV**

Type: 3-pin LVDS Power Header

Pin	Description
1-2	INV_VCC (+12V)
3-4	INV_VCC (+5V)

Default: 1-2

Connector: **JVLCD**

Type: 6-pin Power select Header

Pin	Description
1-2	LCDVCC (3.3V)
3-4	LCDVCC (5V)
5-6	LCDVCC (12V)

Default: 1-2

Connector: **CN\_LVDS**

Type: onboard 40-pin connector for LVDS connector

Connector model: **HIROSE DF13-40DP-1.25V**

Pin	Description	Pin	Description
2	LCDVCC	1	LCDVCC
4	GND	3	GND
6	ATX0-	5	BTX0-
8	ATX0+	7	BTX0+
10	GND	9	GND
12	ATX1-	11	BTX1-
14	ATX1+	13	BTX1+
16	GND	15	GND
18	ATX2-	17	BTX2-
20	ATX2+	19	BTX2+
22	GND	21	GND
24	ACLK-	23	BTX3-
26	ACLK+	25	BTX3+
28	GND	27	GND
30	ATX3-	29	BCLK-
32	ATX3+	31	BCLK+
34	GND	33	GND
36	DDCPCLK	35	N/C
38	DDCPDATA	37	N/C

To setup the LCD, you need the component below:

1. A panel with LVDS interfaces.
2. An inverter for panel's backlight power.
3. A LCD cable and an inverter cable.

For the cables, please follow the pin assignment of the connector to make a cable, because every panel has its own pin assignment, so we do not provide a standard cable; please find a local cable manufacture to make cables.

### LCD Installation Guide:

1. Preparing the **3308870**LCD panel and the **backlight inverter**.

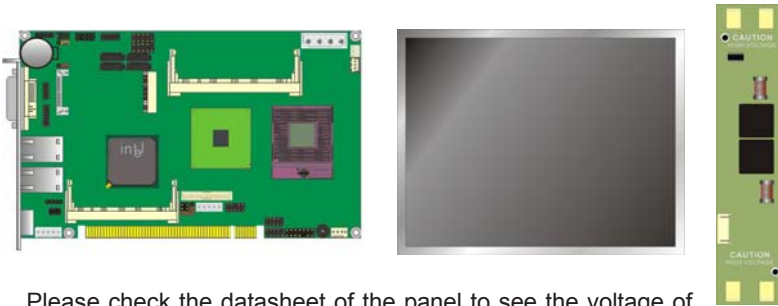

2. Please check the datasheet of the panel to see the voltage of the panel, and set the jumper **JVLCD** to +12V or +5V or +3.3V.
3. You would need a LVDS type cable.

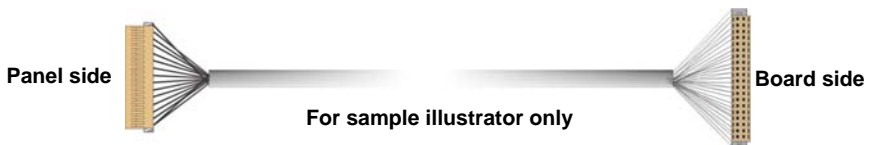

4. To connect all of the devices well.

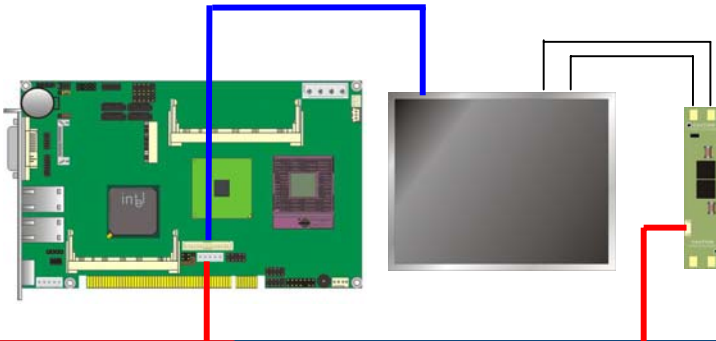

---

After setup the devices well, you need to select the LCD panel type in the BIOS.

The panel type mapping is list below:

<b>18-bit Single channel</b>		<b>24-bit Dual channel</b>	
<b>NO.</b>	<b>Output format</b>	<b>NO.</b>	<b>Output format</b>
1	640 x 480	1	1280 x 768
2	800 x 480	2	1280 x 1024
3	800 x 600	3	1600 x 1200
4	1024 x 768	4	1920 x 1080
5	1280 x 800	5	1920 x 1200
<b>18-bit Dual channel</b>			
1	1280 x 768		
<b>24-bit Single channel</b>			
1	1024 x 768		
2	1280 x 768		
3	1280 x 800		
4	1366 x 768		

## 2.7.2 <HDTV Interface>

The board provides an HDTV interface with Intel GM45, support PAL and NTSC of TV system, and display (clone or extended desktop) function with VGA, DVI and LVDS.

Connector: **CN\_HDTV**

Connector type: 10-pin header HDTV connector pitch 2.54mm (**Optional cable**)

Pin Number	Description	Pin Number	Description
1	GND	2	DACB_L
3	DACC_L	4	GND
5	GND	6	N/C
7	DACA_L	8	GND
9	N/C	10	N/C

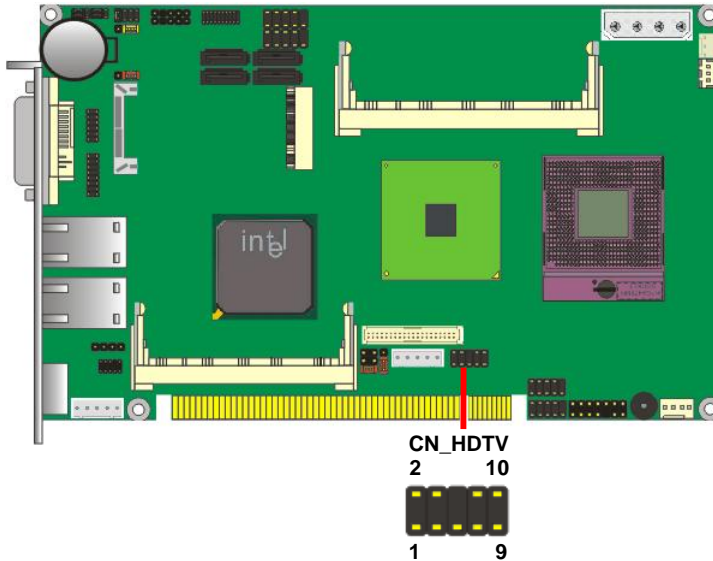

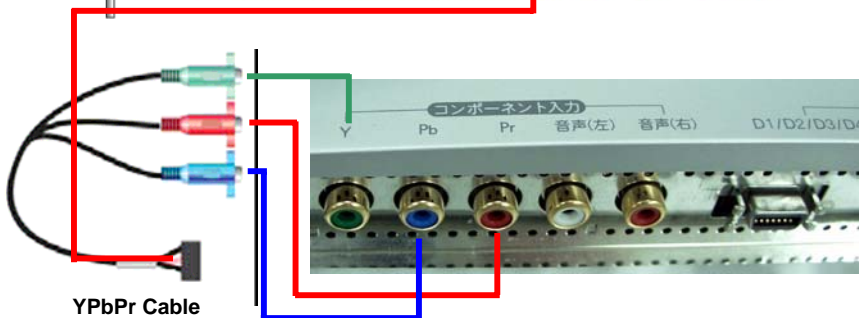
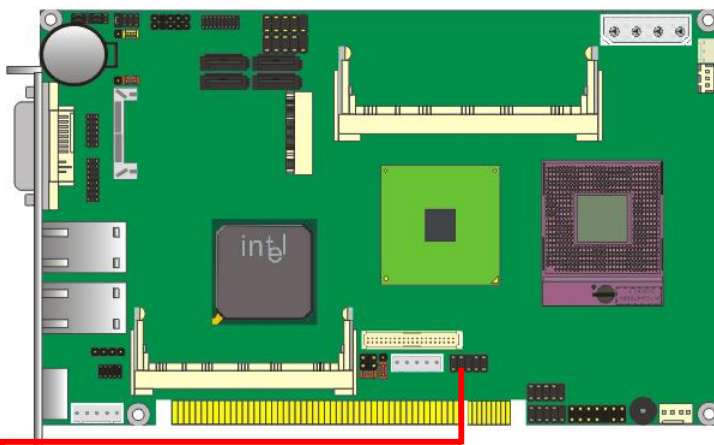

YPbPr Cable  
(Optional cable)

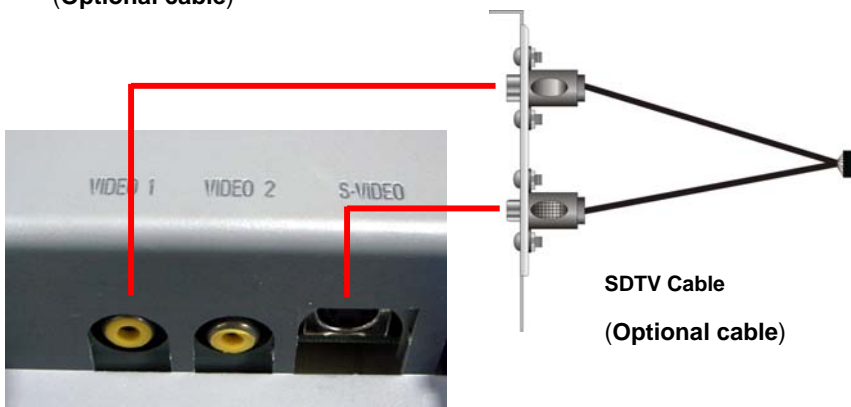

SDTV Cable  
(Optional cable)

---

## 2.8 <Integrated Audio Interface>

The board integrates onboard audio interface with REALTEK ALC888 codec, with Intel next generation of audio standard as High Definition Audio, it offers more sound and other advantages than former HD audio compliance.

The main specifications of ALC888 are:

- **High-performance DACs with 100dB S/N ratio**
- **2 DAC channels support 16/20/24-bit PCM format for 2 audio solution**
- **16Compatible with HD**
- **Meets Microsoft WHQL/WLP 2.0 audio requirements**

The board provides 2 channels audio phone jacks and MIC-in port for front I/O panel through audio cable.

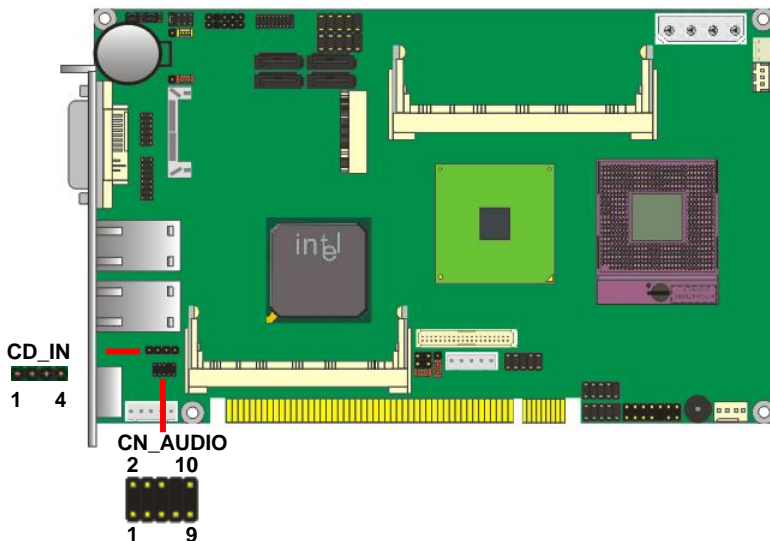

---

**Connector: CN\_AUDIO**

Type: 10-pin (2 x 5) header (pitch = 2.54mm x 1.27mm)

Pin	Description	Pin	Description
1	MIC_L	2	Ground
3	MIC_R	4	Reserve
5	Speaker_R	6	MIC Detect
7	SENSE	8	N/C
9	Speaker_L	10	Speaker Detect

**Connector: CD\_IN**

Type: 4-pin header (pitch = 2.54mm)

Pin	Description
1	CD – Left
2	Ground
3	Ground
4	CD – Right

---

## 2.9 <GPIO Interface>

The board provides a programmable 8-bit digital I/O interface; you can use this general purpose I/O port for system control like POS or KIOSK.

Connector: **CN\_DIO**

Type: 12-pin (6 x 2) header (pitch = 2.0mm)

Pin	Description	Pin	Description
1	Ground	2	Ground
3	GP10	4	GP14
5	GP11	6	GP15
7	GP12	8	GP16
9	GP13	10	GP17
11	VCC	12	+12V

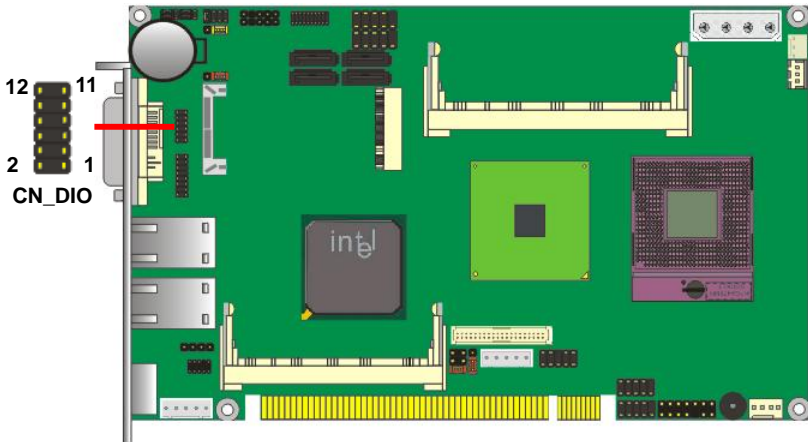

---

## 2.10 <Power Supply>

### 2.10.1 <Power Input>

The board requires onboard 4-pin DC 5V/12V power required, optional 5VSB for ATX.

Connector: **DC\_IN**

Type: 4-pin DC power connector

Pin	Description
1	+12V
2	Ground
3	Ground
4	+5V

Connector: **CN\_PS**

Type: 3-pin ATX function connector

Pin	Description
1	5VSTBY
2	Ground
3	-PSON

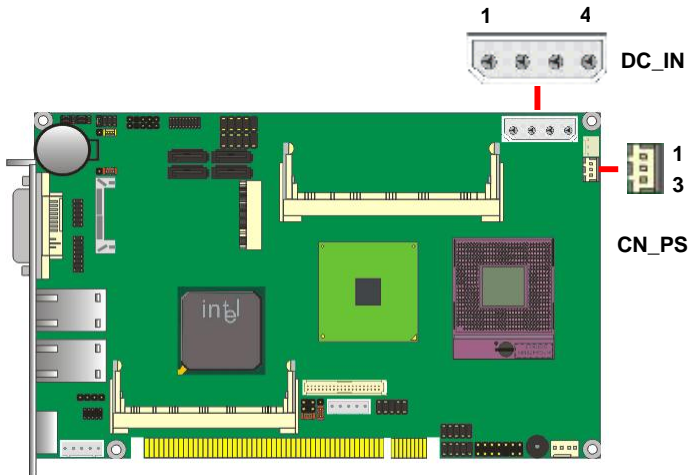

## 2.11 <Switch and Indicator>

The **JFRNT** provides front control panel of the board, such as power button, reset and beeper, etc. Please check well before you connecting the cables on the chassis.

Connector: **JFRNT**

Type: onboard 14-pin (2 x 7) header pitch = 2.54mm

Function	Signal	PIN		Signal	Function
<b>IDE LED</b>	HDLED+	1	2	PWRLED+	<b>Power LED</b>
	HDLED-	3	4	N/C	
<b>Reset</b>	Reset+	5	6	PWRLED-	<b>Speaker</b>
	Reset-	7	8	SPK+	
N/C		9	10	N/C	
<b>Power</b>	PWRBT-	11	12	N/C	
<b>Button</b>	PWRBT+	13	14	SPK-	

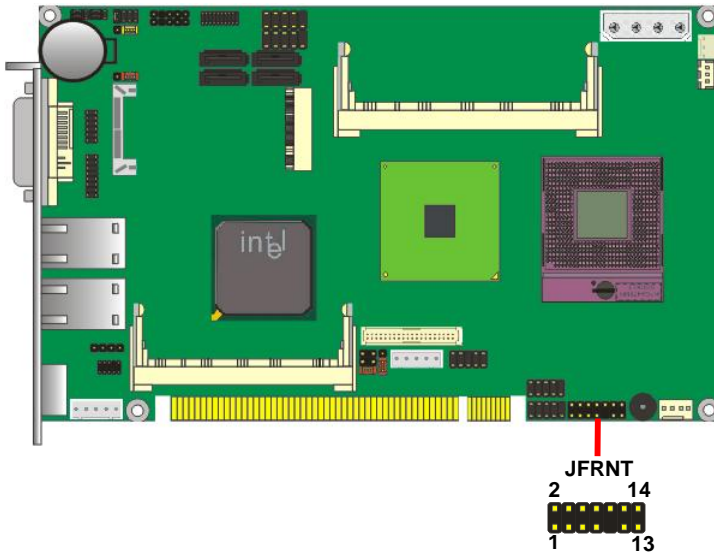

## 2.12 <Serial Port>

The board supports one RS232 serial port and one jumper selectable RS232/422/485 serial ports. The jumper JCSEL1 and JCSEL2 can let you configure the communicating modes for COM2.

Connector: **CN\_COM**

Type: 20-pin (2 x 10) header pitch = 2.54x1.27mm

Pin	Description	Pin	Description
1	DCD1	2	RXD1
3	TXD1	4	DTR1
5	Ground	6	DSR1
7	RTS1	8	CTS1
9	RI1	10	N/C
11	DCD2/422TX-/485-	12	RX2/422TX+/485+
13	TX2/422RX+	14	DTR2/422RX-
15	Ground	16	DSR2
17	RTS2	18	CTS2
19	RI2	20	N/C

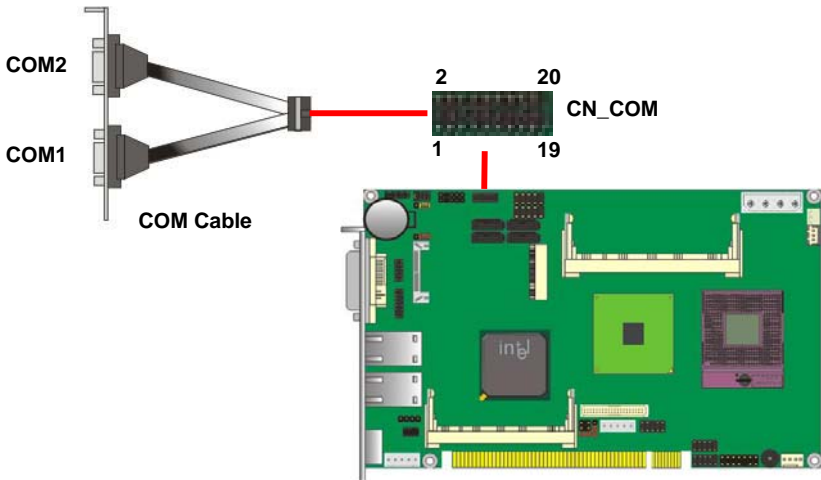

# Setting RS-232/RS-422/RS-485/IrDA:

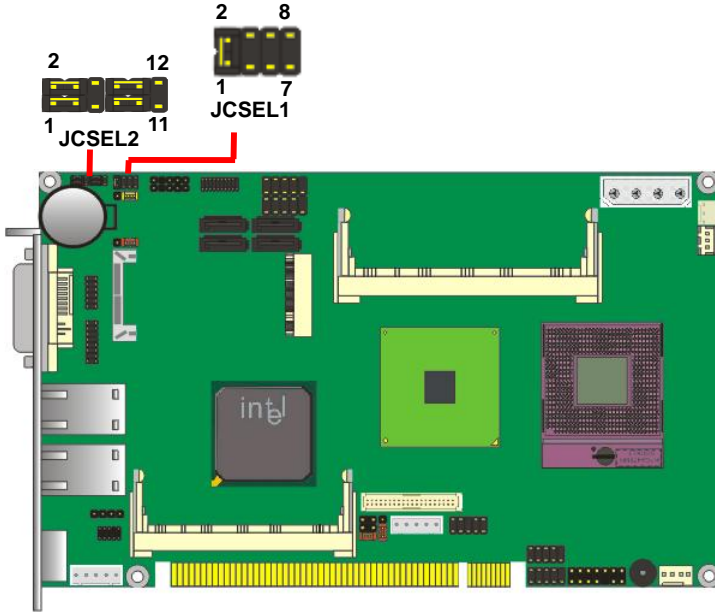

Function	JCSSEL1	JCSSEL2
IrDA		
RS-422		
RS-485		
RS-232		

Default: RS-232

## 2.13 <USB Ports>

Based on ICH9M, the board provides eight USB2.0 ports with provides up to 480Mbps of transferring rate.

Interface	USB2.0
Controller	ICH9M
Transfer Rate	Up to 480Mb/s
Output Current	500mA

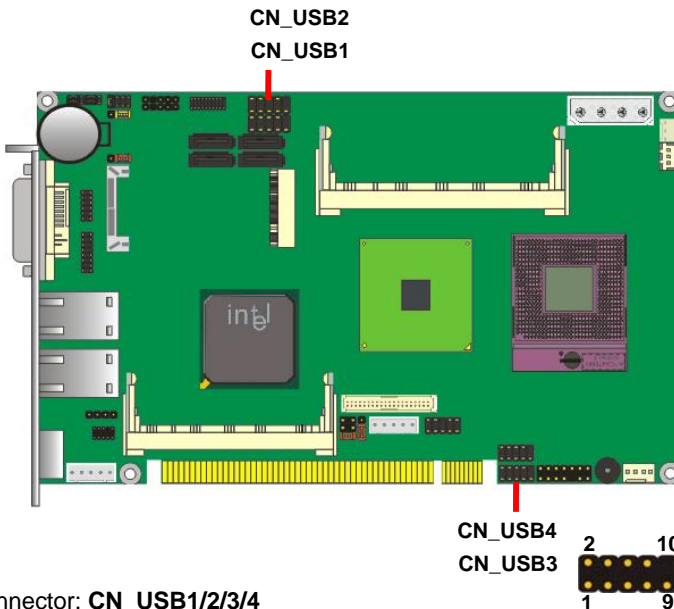

Connector: **CN\_USB1/2/3/4**

Type: 10-pin 5 x 2 header for dual USB Ports pitch = 2.54mm

Pin	Description	Pin	Description
1	VCC	2	VCC
3	Data0-	4	Data1-
5	Data0+	6	Data1+
7	Ground	8	Ground
9	Ground	10	N/C

PS: The USB2.0 will be only active when you connecting with the USB2.0 devices, if you insert an USB1.1 device, the port will be changed to USB1.1 protocol automatically. The transferring rate of USB2.0 as 480Mbps is depending on device capacity, exact transferring rate may not be up to 480Mbps.

## 2.14 <Keyboard & Mouse Port>

### 2.14.1 <PS2 Port>

The PS/2 connector supports standard PS/2 keyboard directly or both PS/2 keyboard and mouse through for PS/2 Y-cable.

Connector: **PS2**

Type: 6-pin Mini-DIN connector on bracket

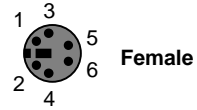

Pin	1	2	3	4	5	6
Description	KBCLK	MSCLK	Ground	VCC	KBDATA	MSDATA

### 2.14.2 <ATKB Port>

Connector: **CN\_ATKB**

Type: 5-pin box header

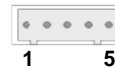

Pin	1	2	3	4	5
Description	VCC	Ground	N/C	KBDATA	KBCLK

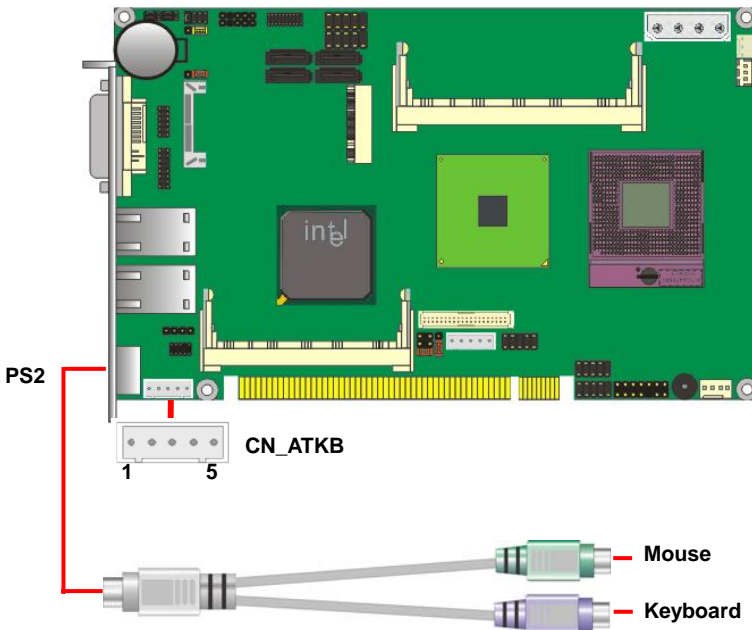

---

## 2.15 <PCI Express Mini Card>

The PCI Express Mini Cards are 30 x 56 mm. There is a 52 pin edge connector.

Connector: **MINI\_CARD**

Type: 52-pin edge connector

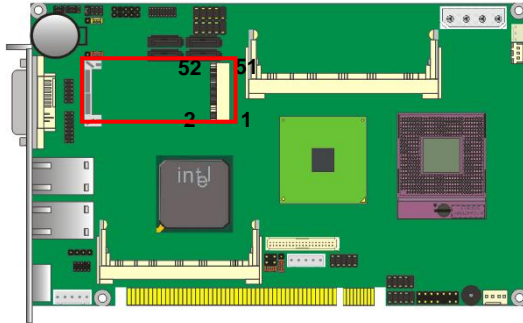

## 2.16 <Mini PCI Interface>

The system connector for Type III consists of a 124-pin card edge type connector.

Connector: **MINI-PCI**

Type: 124-pin Type III edge connector

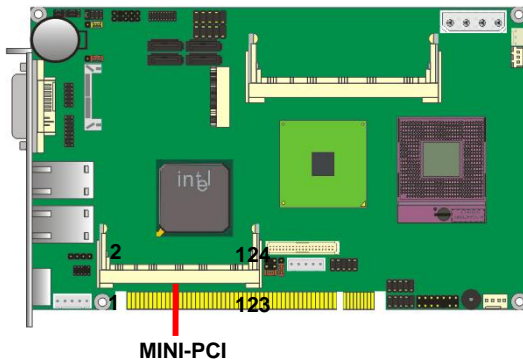

# Chapter 3 <System Setup>

## 3.1 <Audio Configuration>

The board integrates Intel® ICH9M with REALTEK® ALC888 codec. It can support 2-channel sound under system configuration. Please follow the steps below to setup your sound system.

1. Install REALTEK HD Audio driver.
2. Launch the control panel and Sound Effect Manager.

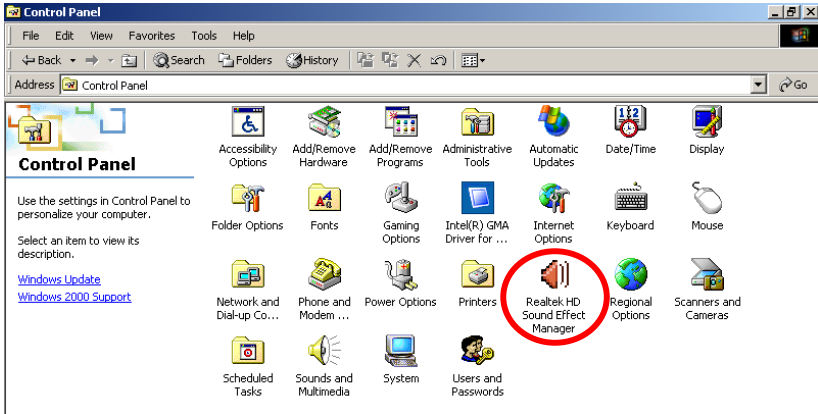

3. Select Speaker Configuration



## 3.2 <Display Properties Setting>

Based on Intel GM45 GMCH with GMA 4500MHD (Graphic Media Accelerator) up to 1024MB shared with system memory, the board supports two DACs for display device as different resolution and color bit.

Please install the Intel Graphic Driver before you starting setup display devices.

1. Click right button on the desktop to lunch **display properties**
2. Click **Advanced** button for more specificity setup.

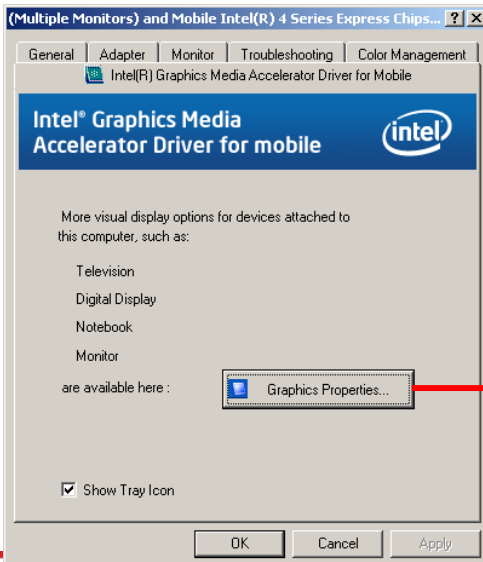
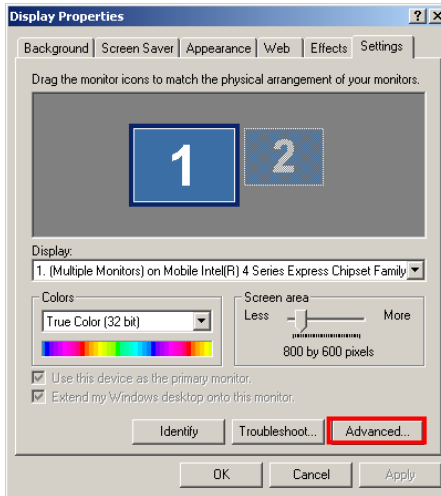

Click **Graphics Properties...** for advanced setup

3. This setup options can let you define each device settings.

Select **Intel(R) Dual Display Clone** for Colors, Resolution and Refresh Rate

Select **Dual Display Clone** to setup the dual display mode as same screen

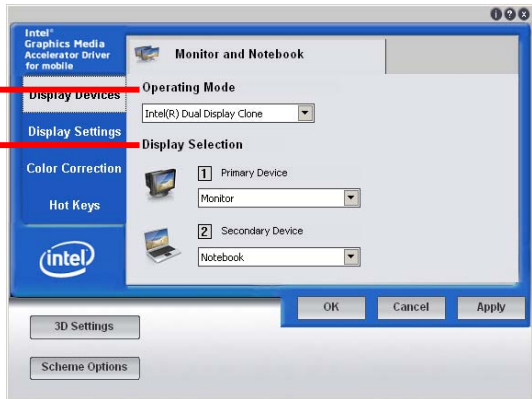

Select **Extended Desktop** for Colors, Resolution and Refresh Rate

Select **Extended Desktop** to setup the dual display mode as same screen

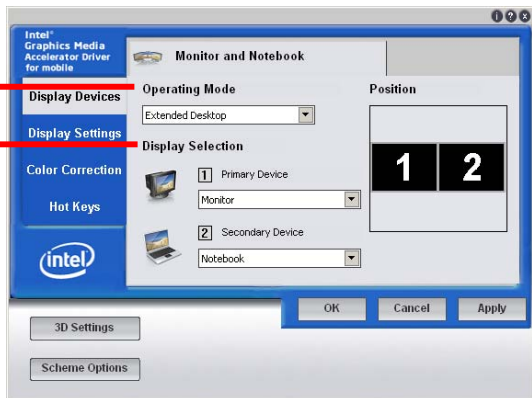

# Appendix A <I/O Port Pin Assignment>

## A.1 <SMBUS Port>

Connector: **CN\_SMBUS**

Type: 5-pin header for SMBUS Port

Pin	Description
1	VCC
2	N/C
3	SMBDATA
4	SMBCLK
5	Ground



## A.2 <IrDA Port>

Connector: **CN\_IR**

Type: 5-pin header for SIR Ports

Pin	Description
1	VCC
2	N/C
3	IRRX
4	Ground
5	IRTX



*JCSEL1 must jump to "SIR"*

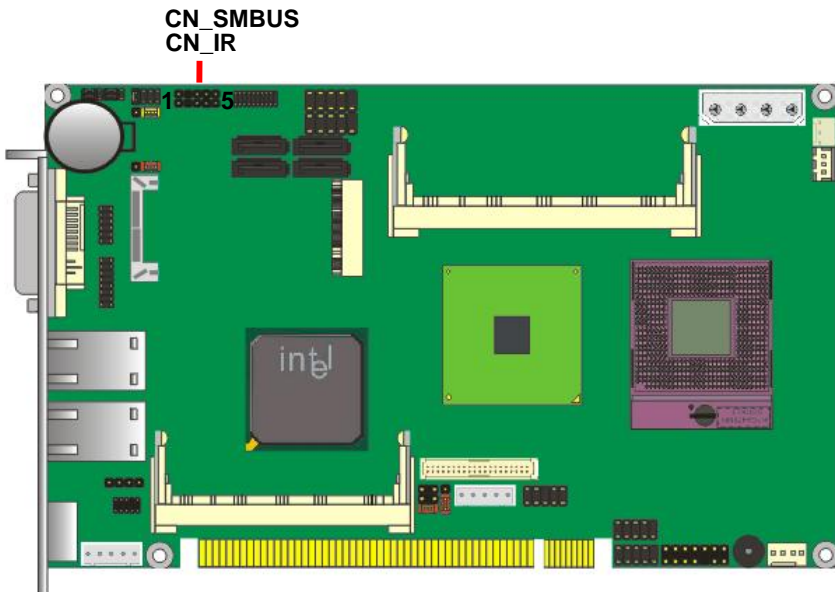

---

Any advice or comments about our products and service, or anything we can help you with please don't hesitate to contact us. We will do our best to support your products, projects and business.



Address: Global American, Inc.  
17 Hampshire Drive  
Hudson, NH 03051

Telephone: Toll Free (U.S. Only) 800-833-8999  
(603)886-3900

FAX: (603)886-4545

Website: <http://www.globalamericaninc.com>  
Support: Technical Support at Global American

