



integration with integrity

User's Manual

3.5" Embedded Controller 3307980

AMD Geode LX

Version 1.0

Copyrights

This manual is copyrighted and all rights are reserved. It does not allow any non authorization in copied, photocopied, translated or reproduced to any electronic or machine readable form in whole or in part without prior written consent from the manufacturer.

In general, the manufacturer will not be liable for any direct, indirect, special, incidental or consequential damages arising from the use of inability to use the product or documentation, even if advised of the possibility of such damages. The manufacturer keeps the rights in the subject to change the contents of this manual without prior notices in order to improve the function design, performance, quality and reliability. The author assumes no responsibility for any errors or omissions, which may appear in this manual, nor does it make a commitment to update the information contained herein.

Trademarks

Intel is a registered trademark of Intel Corporation.

Award is a registered trademark of Award Software, Inc.

All other trademarks, products and or product's name mentioned herein are mentioned for identification purposes only, and may be trademarks and/or registered trademarks of their respective companies or owners.

Table of Contents

Introduction	1
Product Description.....	1
Checklist.....	2
Specifications	3
Board Dimensions	4
Installations	5
Installing the Memory	6
Setting the Jumpers	7
Connectors on 3307980.....	10
Appendix	19
A. I/O Port Address Map.....	19
B. Interrupt Request Lines (IRQ).....	20
C. Watchdog Timer Configuration.....	21

Introduction

Product Description

The 3307980 3.5-inch disk size SBC incorporates the AMD Geode LX processor with speeds of 433MHz (LX700) or 500MHz (LX800). It comes with one DDR SO-DIMM socket that has a capacity of 1GB system memory. The board supports one 10/100Mbps Ethernet, using a Realtek RTL8100C controller. A 2D graphics controller comes integrated on the board that supports CRT and TFT LCD displays. Useful interface includes four USB 2.0 ports, 2 COM ports, and one PCI-104 expansion slot. Other expansion options are available with the Compact Flash socket and PCMCIA connector.

3307980

FEATURES:

- Embedded AMD Geode LX processor, 433MHz (LX700) / 500MHz (LX800)
- DDR SO-DIMM x 1, Max. 1GB
- Realtek RTL8100C 10/100Mbps Ethernet
- Integrated LX800/LX700 2D VGA controller, supports CRT and TFT LCD display
- 4 x USB 2.0, 2 x COM, CF socket, Watchdog timer, Digital I/O
- PCI-104 expansion, optional PCMCIA connector
- Dimensions: 145mm x 102mm (5.7" x 4")

Checklist

Your 3307980 package should include the items listed below.

- The 3307980 AMD Geode LX 3.5-inch Disk Size SBC
- This User's Manual
- 1 CD containing chipset drivers and flash memory utility
- Optional cables

Specifications

CPU	AMD Geode LX CPU, 481-ball BGA
CPU Internal Speed	LX800 @500MHz LX700 @433MHz
Power Management	APM
BIOS	Award BIOS
Chipset	AMD CS5536 I/O companion multi-function south bridge
Memory	One DDR SO-DIMM socket, Max. up to 1GB
Graphic	LX800/LX700 built-in high performance 2D graphic controller, supports TFT, LVDS LCD & CRT display
LVDS	24-bit single channel LVDS
Ethernet	Realtek RTL8100C-LF 10/100Mbps Ethernet chip
IDE	CS5536 built-in one channel UDMA100 IDE - 44-pin header x1 - Compact Flash (type II) connector x1
Audio	Realtek ALC203 AC97 audio codec, supports 2-CH Line-Out, Line-In & MIC
USB	CS5536 built-in USB2.0 controller, support 4 ports
PCMCIA	TI PCI1510 Card bus controller (3307980B only)
LPC I/O	Winbond W83627HF: KB/Mouse controller, Parallel, IrDA, Floppy, COM1, COM2 (RS232) & Hardware monitor (3 thermal inputs, 4 voltage monitor inputs, VIDO-4 & 2 Fan Headers)
PCI Arbiter	AT209S PCI arbiter/clock buffer, extend PCI devices (master) from 1 to 3
RTC	CS5536 built-in, with on board Lithium battery
Edge Connectors	DB-9 connector x1 for COM1 (RS232 only) 6-pins Mini-DIN connector x1 for PS/2 KB & Mouse (Y cable) USB connector x1 for USB0 DB-15 connector x1 for CRT RJ-45 connector x1 for LAN
Onboard Headers	PCMCIA connector x1 for Card Bus (3307980B only) DF13-20 header x1 for LVDS channel Compact Flash Socket x1 for CF card 10-pin header x1 for COM2 (RS232 only) 4-pin header for USB1 10-pin header x1 for USB2, 3 26-pin header x1 for LPT port 44-pin header x1 for IDE 34-pin header x1 for FDD 12-pin header x1 for Audio 4-pin header x1 for IrDA 10-pin header x1 for Digital I/O 44-pin header x1 for TFT LCD panel
Expansion Slot	PCI-104 w/ 4 mounting holes
Digital I/O	Supports 4 In / 4 Out
Power	+12V DC-in
Watchdog Timer	Software programmable, supports 1~255 sec. system reset
RoHS Compliant	Yes
Board Size	145 x 102mm

Board Dimensions

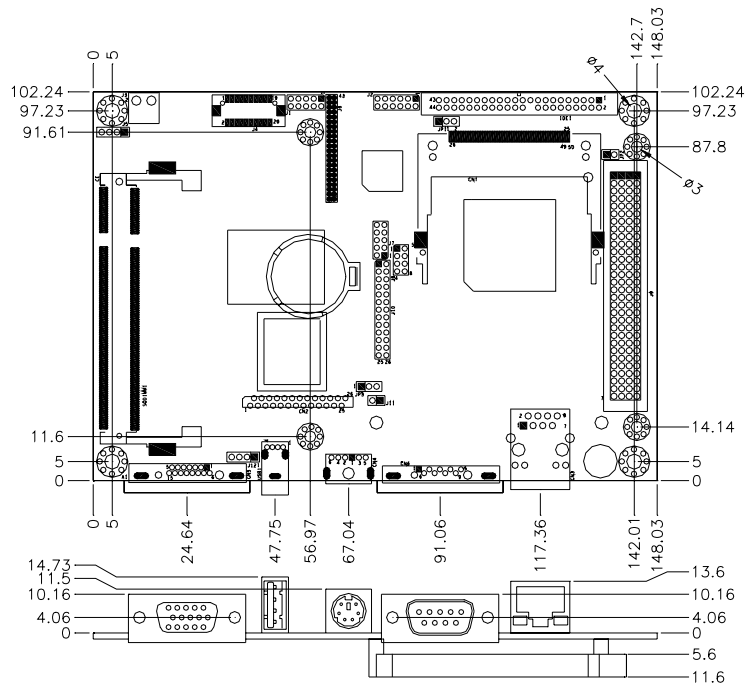

Installations

This section provides information on how to use the jumpers and connectors on the 3307980 in order to set up a workable system. The topics covered are:

Installing the Memory	6
Setting the Jumpers	7
Connectors on 3307980	10

Installing the Memory

The 3307980 board supports one SODIMM DDR memory socket for a maximum total memory. The memory module capacities supported are 128MB, 256MB, 512MB and 1GB.

Installing and Removing Memory Modules

To install the DDR modules, locate the memory slot on the board and perform the following steps:

1. Hold the DDR module so that the key of the DDR module align with those on the memory slot. Insert the module into the socket at a slight angle (approximately 30 degrees). Note that the socket and module are both keyed, which means that the module can be installed only in one direction.
2. To seat the memory module into the socket, apply firm and even pressure to each end of the module until you feel it slip down into the socket.
3. With the module properly seated in the socket, rotate the module downward. Continue pressing downward until the clips at each end lock into position.
4. To remove the DDR module, press the clips with both hands.

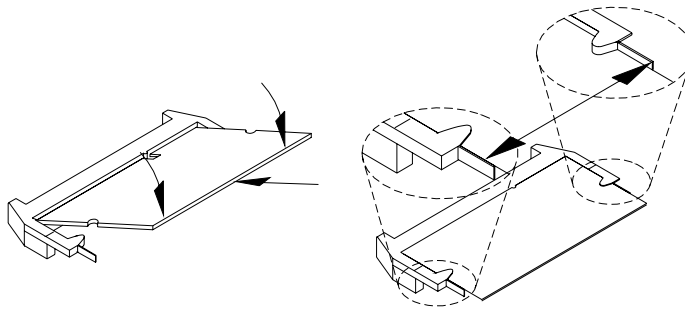

Setting the Jumpers

Jumpers are used on 3307980 to select various settings and features according to your needs and applications. Contact your supplier if you have doubts about the best configuration for your needs. The following lists the connectors on 3307980 and their respective functions.

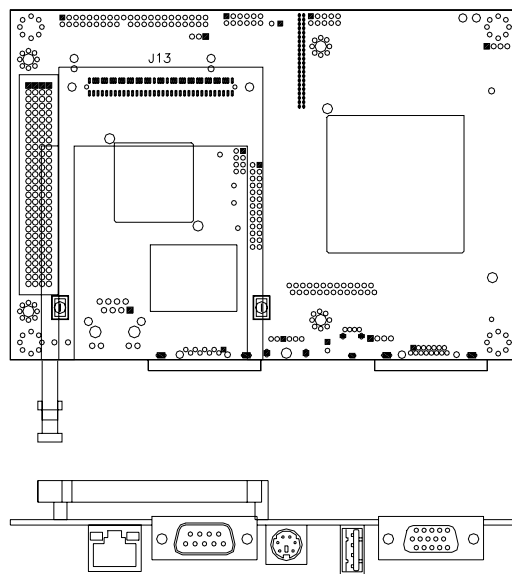
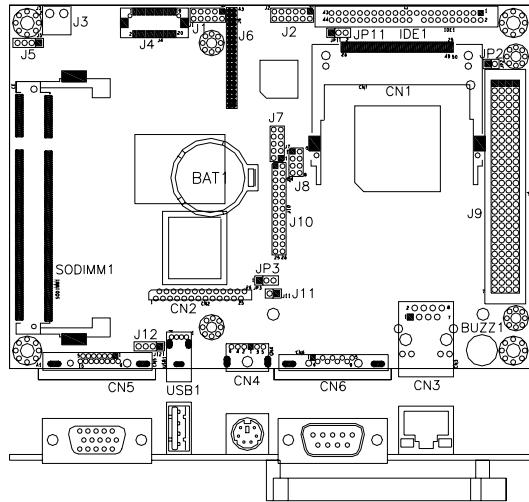

Jumper Locations on 3307980	8
JP1: LVDS VDD Select (5V / 3.3V).....	9
JP2: CF Connector master/Slave Setting.....	9
JP3: Clear CMOS Setting.....	9

Jumper Locations on 3307980





Jumpers on 3307980.....	Page
JP1: LVDS VDD Select (5V / 3.3V)	9
JP2: CF Connector master/Slave Setting	9
JP3: Clear CMOS Setting	9

JP1: LVDS VDD Select (5V / 3.3V)



JP1	VDD Setting
 1 2 3	3.3V
 1 2 3	5V

JP2: CF Connector master/Slave Setting

JP2	Setting	Function
 1 2	Short/Closed	Master
 1 2	Open	Slave

JP3: Clear CMOS Setting

Use JP3 to clear the CMOS contents. *Note that the power connector should be disconnected from the board before clearing CMOS.*

JP3	Function
 1 2 3	Normal (default)
 1 2 3	Clear CMOS

Connectors on 3307980

The connectors on 3307980 allows you to connect external devices such as keyboard, floppy disk drives, hard disk drives, printers, etc. The following table lists the connectors on 3307980 and their respective functions.

Connector Locations on 3307980.....	11
CN1: Compact Flash Card Socket.....	12
CN2: FDD Connector.....	12
CN3:RJ45 Connector.....	12
CN4: PS/2 Keyboard and Mouse Connector.....	12
CN5: VGA CRT Connector.....	13
CN6, J7: Serial Ports.....	13
IDE1: IDE Connector.....	14
J1: Digital 4-in 4-out Connector.....	14
J2: External Audio Connector.....	15
J3: Power DC-In.....	15
J4: LVDS Connectors.....	15
J5: IrDA Connector.....	15
J6: TFT Panel Connector.....	16
USB1, J8, J12: USB Connectors.....	16
J9: PCI-104 Connector.....	17
J10: Parallel Port Connector.....	18
J11: Reset Switch.....	18
J13: Cardbus Connector.....	18
SODIMM1: SO DIMM Socket.....	18

Connector Locations on 3307980

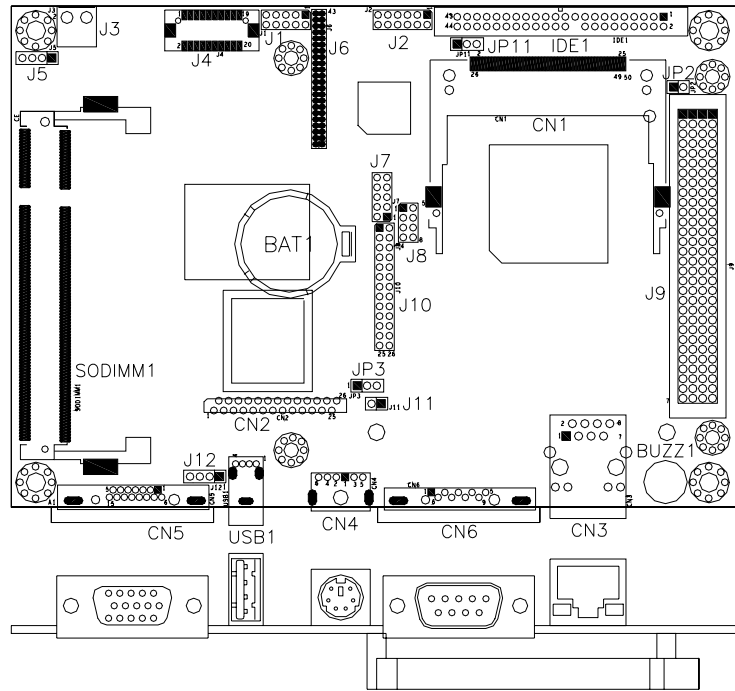

Connectors on 3307980.....	Page
CN1: Compact Flash Card Socket	12
CN2: FDD Connector	12
CN3:RJ45 Connector	12
CN4: PS/2 Keyboard and Mouse Connector.....	12
CN5: VGA CRT Connector.....	13
CN6, J7: Serial Ports	13
IDE1: IDE Connector.....	14
J1: Digital 4-in 4-out Connector	14
J2: External Audio Connector.....	15
J3: Power DC-In.....	15
J4: LVDS Connectors	15
J5: IrDA Connector	15
J6: TFT Panel Connector	16
USB1, J8, J12: USB Connectors.....	16
J9: PCI-104 Connector.....	17
J10: Parallel Port Connector	18
J11: Reset Switch	18
J13: Cardbus Connector	18
SODIMM1: SO DIMM Socket.....	18

CN1: Compact Flash Card Socket

CN2: FDD Connector

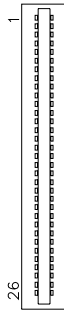

Signal Name	Pin #	Pin #	Signal Name
VCC	1	2	INDEX
VCC	3	4	DRV_SEL
VCC	5	6	DSK_CH
NC	7	8	NC
NC	9	10	MOTOR
DINST	11	12	DIR
NC	13	14	STEP
GND	15	16	WDATA
GND	17	18	WGATE
GND	19	20	TRACK
NC	21	22	WPROT
GND	23	24	RDATA
GND	25	26	SIDE

CN3:RJ45 Connector

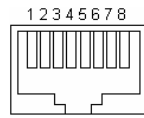

Pin #	Signal Name
1	TD+
2	TD-
3	RD+
4	RJ45-4A
5	RJ45-5A
6	RD-
7	RJ45-7A
8	RJ45-8A

CN4: PS/2 Keyboard and Mouse Connector

CN4 uses a Y-cable with dual D-connectors for a PS/2 keyboard and a PS/2 mouse.

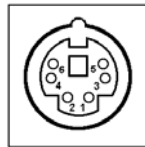

Pin #	Signal Name
1	Keyboard data
2	Mouse data
3	Ground
4	Vcc
5	Keyboard Clock
6	Mouse Clock

CN5: VGA CRT Connector

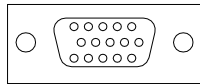

Signal Name	Pin	Pin	Signal Name
Red	1	2	Green
Blue	3	4	NC
GND	5	6	GND
GND	7	8	GND
Vcc	9	10	GND
N.C.	11	12	DDCDA
HSYNC	13	14	VSYNC
DDCCLK	15		

CN6, J7: Serial Ports

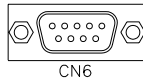
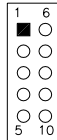

Pin #	Signal Name (RS-232)
1	DCD, Data carrier detect
2	RXD, Receive data
3	TXD, Transmit data
4	DTR, Data terminal ready
5	Ground
6	DSR, Data set ready
7	RTS, Request to send
8	CTS, Clear to send
9	RI, Ring indicator
10	No Connect.

CN6 is the D-sub type COM1 serial port connector, while J7 (COM2) is a pin header type COM2 serial port connector.

IDE1: IDE Connector

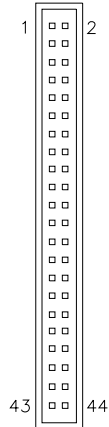

Signal Name	Pin #	Pin #	Signal Name
Reset IDE	1	2	Ground
Host data 7	3	4	Host data 8
Host data 6	5	6	Host data 9
Host data 5	7	8	Host data 10
Host data 4	9	10	Host data 11
Host data 3	11	12	Host data 12
Host data 2	13	14	Host data 13
Host data 1	15	16	Host data 14
Host data 0	17	18	Host data 15
Ground	19	20	Key
DRQ0	21	22	Ground
Host IOW	23	24	Ground
Host IOR	25	26	Ground
IOCHRDY	27	28	Host ALE
DACK0	29	30	Ground
IRQ14	31	32	No connect
Address 1	33	34	No connect
Address 0	35	36	Address 2
Chip select 0	37	38	Chip select 1
Activity	39	40	Ground
Vcc	41	42	Vcc
Ground	43	44	N.C.

J1: Digital 4-in 4-out Connector

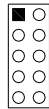

Signal Name	Pin	Pin	Signal Name
Ground	1	2	Vcc
Out3	3	4	Out1
Out2	5	6	Out0
IN3	7	8	IN1
IN2	9	10	IN0

J2: External Audio Connector

J2 is a 12-pin header that is used to connect to the optional audio cable card that integrates jacks for Line In, Line Out and Mic.

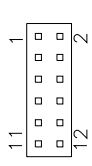

Signal Name	Pin #	Pin #	Signal Name
LINEOUT_R	1	2	LINEOUT_L
Ground	3	4	Ground
LINEIN_R	5	6	LINEIN_L
Ground	7	8	Ground
Mic-In	9	10	VREFOUT
Ground	11	12	Protect pin

J3: Power DC-In



Pin #	Signal Name
1	DC In (12V only)
2	Ground

J4: LVDS Connectors

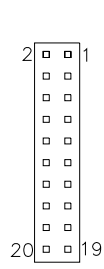

Signal Name	Pin #	Pin #	Signal Name
TX0-	2	1	TX0+
Ground	4	3	Ground
TX1-	6	5	TX1+
5V/3.3V	8	7	Ground
TX3-	10	9	TX3+
TX2-	12	11	TX2+
Ground	14	13	Ground
TXC-	16	15	TXC+
5V/3.3V	18	17	ENABKL
+12V	20	19	+12V

*Depends on JP1 setting (1-2 for 3.3V/default, 2-3 for 5V).

J5: IrDA Connector

J5 is used for an optional IrDA connector for wireless communication.

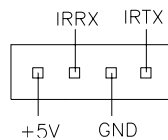

Pin #	Signal Name
1	+5V
2	Ir RX
3	Ground
4	Ir TX

J6: TFT Panel Connector

J6 is the pin header for TFT flat panel LCD displays.

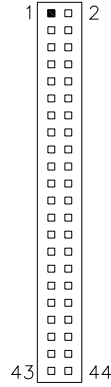

Signal Name	Pin #	Pin #	Signal Name
+12V	1	2	+12V
Ground	3	4	Ground
5V/3.3V	5	6	5V/3.3V
N.C.	7	8	Ground
R0	9	10	R1
R2	11	12	R3
R4	13	14	R5
R6	15	16	R7
G0	17	18	G1
G2	19	20	G3
G4	21	22	G5
G6	23	24	G7
B0	25	26	B1
B2	27	28	B3
B4	29	30	B5
B6	31	32	B7
Ground	33	34	Ground
SHFCLK	35	36	FLM(VSYNC)
DISPENA(MDE)	37	38	LP(HSYNC)
Ground	39	40	ENABKL
Ground	41	42	N.C.
ENAVDD	43	44	5V/3.3V

*Depends on JP1 setting (1-2 for 3.3V/default, 2-3 for 5V).

USB1, J8, J12: USB Connectors

The J8, J12 USB pin header connectors support three USB 2.0 ports via optional USB cables. The 3307980 also supports an embedded USB connector, USB1, which supports another USB 2.0 port.

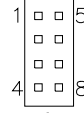

Signal Name	Pin	Pin	Signal Name
+5V	1	5	Ground
USB0-	2	6	USB1+
USB0+	3	7	USB1-
Ground	4	8	+5V

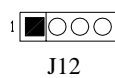

Pin #	Signal Name
1	+5V
2	USB-
3	USB+
4	Ground

J9: PCI-104 Connector
PCI-104 Bus Signal Assignments

J3/P3				
Pin	A	B	C	D
1	GND/5.0V KEY ²	Reserved	+5	AD00
2	VI/O	AD02	AD01	+5V
3	AD05	GND	AD04	AD03
4	C/BE0*	AD07	GND	AD06
5	GND	AD09	AD08	GND
6	AD11	VI/O	AD10	M66EN
7	AD14	AD13	GND	AD12
8	+3.3V	C/BE1*	AD15	+3.3V
9	SERR*	GND	SB0*	PAR
10	GND	PERR*	+3.3V	SDONE
11	STOP*	+3.3V	LOCK*	GND
12	+3.3V	TRDY*	GND	DEVSEL*
13	FRAME*	GND	IRDY*	+3.3V
14	GND	AD16	+3.3V	C/BE2*
15	AD18	+3.3V	AD17	GND
16	AD21	AD20	GND	AD19
17	+3.3V	AD23	AD22	+3.3V
18	IDSEL0	GND	IDSEL1	IDSEL2
19	AD24	C/BE3*	VI/O	IDSEL3
20	GND	AD26	AD25	GND
21	AD29	+5V	AD28	AD27
22	+5V	AD30	GND	AD31
23	REQ0*	GND	REQ1*	VI/O
24	GND	REQ2*	+5V	GNT0*
25	GNT1*	VI/O	GNT2*	GND
26	+5V	CLK0	GND	CLK1
27	CLK2	+5V	CLK3	GND
28	GND	INTD*	+5V	RST*
29	+12V	INTA*	INTB*	INTC*
30	-12V	Reserved	Reserved	GND/3.3V KEY ²

* The shaded area denotes power or ground signals.

* The KEY pins are to guarantee proper module installation. Pin-A1 will be removed and the female side plugged for 5.0V I/O signals and Pin-D30 will be modified in the same manner for 3.3V I/O. It is recommended that both KEY pins (A1 and D30) be electrically connected for GND for shielding.

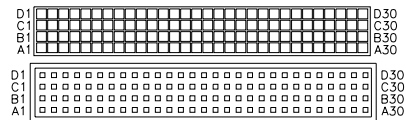

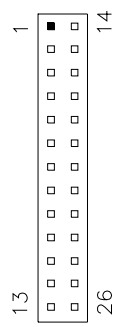
J10: Parallel Port Connector

Signal Name	Pin #	Pin #	Signal Name
Line printer strobe	1	14	AutoFeed
PD0, parallel data 0	2	15	Error
PD1, parallel data 1	3	16	Initialize
PD2, parallel data 2	4	17	Select
PD3, parallel data 3	5	18	Ground
PD4, parallel data 4	6	19	Ground
PD5, parallel data 5	7	20	Ground
PD6, parallel data 6	8	21	Ground
PD7, parallel data 7	9	22	Ground
ACK, acknowledge	10	23	Ground
Busy	11	24	Ground
Paper empty	12	25	Ground
Select	13	N/A	N/A

J11: Reset Switch

Pin #	Signal Name
1	Reset
2	Ground

J13: Cardbus Connector**SODIMM1: SO DIMM Socket**

Appendix

A. I/O Port Address Map

Each peripheral device in the system is assigned a set of I/O port addresses which also becomes the identity of the device. The following table lists the I/O port addresses used.

Address	Device Description
000h - 01Fh	DMA Controller #1
020h - 03Fh	Interrupt Controller #1
040h - 05Fh	Timer
060h	Keyboard Controller (1)
0601h	Control Port
064h	Real Time Clock
070h - 07Fh	Keyboard Controller (2)
080h - 09Fh	DMA Page Register
0A0h - 0BFh	Interrupt Controller #2
0C0h - 0DFh	DMA Controller #2
0F0h - 00FFh	Coprocessor
01F0h - 01F7h 03F6h	IDE (Primary)
02F8h - 02FFh	Serial Port #2(COM2)
0378h - 037Ah	Parallel Port #1(LPT1)
03C0h - 03DFh	Reserved for VGA
03F0h - 03F5h 03F7h	FDD Controller
03F8h - 3FFh	Serial Port #1(COM1)

B. Interrupt Request Lines (IRQ)

Peripheral devices use interrupt request lines to notify CPU for the service required. The following table shows the IRQ used by the devices on board.

Level	Function
IRQ0	System Timer Output
IRQ1	Keyboard
IRQ2	PIC2 (IRQ8-15)
IRQ3	Serial Port #2
IRQ4	Serial Port #1
IRQ5	For PCI
IRQ6	Floppy Disk Controller
IRQ7	Parallel Port #1
IRQ8	Real Time Clock
IRQ9	For PCI
IRQ10	For PCI
IRQ11	For PCI
IRQ12	PS/2 Mouse
IRQ13	Coprocessor
IRQ14	Primary IDE

C. Watchdog Timer Configuration

The WDT is used to generate a variety of output signals after a user programmable count. The WDT is suitable for use in the prevention of system lock-up, such as when software becomes trapped in a deadlock. Under these sort of circumstances, the timer will count to zero and the selected outputs will be driven. Under normal circumstance, the user will restart the WDT at regular intervals before the timer counts to zero.

SAMPLE CODE:

This code and information is provided "as is" without warranty of any kind, either expressed or implied, including but not limited to the implied warranties of merchantability and/or fitness for a particular purpose.

```

;[]=====
; Name   : Enable_And_Set_Watchdog
; IN    : AL - 1sec ~ 255sec
; OUT   : None
;[]=====
Enable_And_Set_Watchdog Proc Near
    push ax                ;save time interval
    call Unlock_Chip

    mov cl, 2Bh
    call Read_Reg
    and al, NOT 10h
    call Write_Reg        ;set GP24 as WDTO

    mov cl, 07h
    mov al, 08h
    call Write_Reg        ;switch to LD8
    mov cl, 0F5h
    call Read_Reg
    and al, NOT 08h
    call Write_Reg        ;set count mode as second

    pop ax
    mov cl, 0F6h
    call Write_Reg        ;set watchdog timer

    mov al, 01h
    mov cl, 30h
    call Write_Reg        ;watchdog enabled

```

```
        call Lock_Chip
        ret
Enable_And_Set_Watchdog Endp

;[=====
;Name   : Disable_Watchdog
;IN    : None
;OUT   : None
;[=====
Disable_Watchdog Proc Near
        call Unlock_Chip

        mov cl, 07h
        mov al, 08h
        call Write_Reg    ;switch to LD8

        xor al, al
        mov cl, 0F6h
        call Write_Reg    ;clear watchdog timer

        xor al, al
        mov cl, 30h
        call Write_Reg    ;watchdog disabled

        call Lock_Chip
        ret
Disable_Watchdog Endp

;[=====
;Name   : Unlock_Chip
;IN    : None
;OUT   : None
;[=====
Unlock_Chip Proc Near
        mov dx, 4Eh
        mov al, 87h
        out dx, al
        out dx, al
        ret
Unlock_Chip Endp

;[=====
;Name   : Lock_Chip
;IN    : None
;OUT   : None
```

```
=====  
:[]=====  
Unlock_Chip Proc Near  
    mov dx, 4Eh  
    mov al, 0Aah  
  
    out dx, al  
    ret  
Unlock_Chip Endp  
:[]=====  
; Name      : Write_Reg  
; IN   : CL - register index  
;     AL - Value to write  
; OUT   : None  
:[]=====  
Write_Reg Proc Near  
    push ax  
    mov dx, 4Eh  
    mov al, cl  
    out dx, al  
    pop ax  
    inc dx  
    out dx, al  
    ret  
Write_Reg Endp  
:[]=====  
; Name      : Read_Reg  
; IN   : CL - register index  
; OUT   : AL - Value to read  
:[]=====  
Read_Reg Proc Near  
    mov al, cl  
    mov dx, 4Eh  
    out dx, al  
    inc dx  
    in  al, dx  
    ret  
Read_Reg Endp  
:[]=====
```

Any advice or comments about our products and service, or anything we can help you with please don't hesitate to contact with us. We will do our best to support your products, projects and business.



Address: Global American, Inc.
17 Hampshire Drive
Hudson, NH 03051

Telephone: Toll Free (U.S. Only) 800-833-8999
(603)886-3900

FAX: (603)886-4545

Website: <http://www.globalamericaninc.com>

E-Mail: salesinfo@globalamericaninc.com
