



integration with integrity

User's Manual

PICMG 1.3 - 3307740

Version 1.0

Copyrights

This manual is copyrighted and all rights are reserved. It does not allow any non authorization in copied, photocopied, translated or reproduced to any electronic or machine readable form in whole or in part without prior written consent from the manufacturer.

In general, the manufacturer will not be liable for any direct, indirect, special, incidental or consequential damages arising from the use of inability to use the product or documentation, even if advised of the possibility of such damages. The manufacturer keeps the rights in the subject to change the contents of this manual without prior notices in order to improve the function design, performance, quality and reliability. The author assumes no responsibility for any errors or omissions, which may appear in this manual, nor does it make a commitment to update the information contained herein.

Trademarks

Intel is a registered trademark of Intel Corporation.

Award is a registered trademark of Award Software, Inc.

All other trademarks, products and or product's name mentioned herein are mentioned for identification purposes only, and may be trademarks and/or registered trademarks of their respective companies or owners.

Revision

| Date | Version | Changes |
|------------|---------|-----------------|
| 2007-03-23 | 1.00 | Initial release |

Packing List



NOTE:

If any of the components listed in the checklist below are missing, please do not proceed with the installation. Contact GLOBAL AMERICAN Sales Representative regarding 3307740 at [Tech Support](#)

The items listed below should all be included in the 3307740 package.

- 1 x 3307740 single board computer
- 1 x IDE cable
- 1 x SATA power cable
- 2 x SATA cables
- 1 x Dual RS-232 cable
- 1 x USB cable
- 1 x Mini jumper pack
- 1 x Utility CD
- 1 x 1 x QIG (quick installation guide)

Images of the above items are shown in **Chapter 3**.

Table of Contents

| | | |
|----------|--|-----------|
| 1 | INTRODUCTION..... | 19 |
| 1.1 | INTRODUCTION..... | 20 |
| 1.1.1 | 3307740 Benefits..... | 20 |
| 1.1.2 | 3307740 Features | 20 |
| 1.2 | 3307740 OVERVIEW..... | 21 |
| 1.2.1 | 3307740 Overview Photo..... | 21 |
| 1.2.2 | 3307740 Peripheral Connectors and Jumpers | 21 |
| 1.2.3 | Technical Specifications..... | 22 |
| 2 | DETAILED SPECIFICATIONS | 25 |
| 2.1 | OVERVIEW..... | 26 |
| 2.2 | DIMENSIONS..... | 26 |
| 2.2.1 | Board Dimensions..... | 26 |
| 2.2.2 | External Interface Panel Dimensions | 27 |
| 2.3 | DATA FLOW | 27 |
| 2.4 | COMPATIBLE PROCESSORS | 28 |
| 2.4.1 | Compatible Processor Overview | 28 |
| 2.5 | INTEL [®] 915GM NORTHBRIDGE CHIPSET | 29 |
| 2.5.1 | Intel [®] 915GM Overview..... | 29 |
| 2.5.2 | Intel [®] 915GM Memory Support..... | 30 |
| 2.5.3 | Intel [®] 915GM PCIe x16..... | 31 |
| 2.5.3.1 | PCIe x16 Bus Overview..... | 31 |
| 2.5.3.2 | PCIe x16 Expansion Options | 32 |
| 2.5.3.3 | PCIe x16 Bus Specifications..... | 32 |
| 2.5.4 | Intel [®] 915GM Integrated Graphics | 32 |
| 2.5.4.1 | Intel [®] 915GM Analog CRT Support..... | 33 |
| 2.5.4.2 | Intel [®] 915GM LVDS Support..... | 33 |
| 2.5.4.3 | Intel [®] 915GM TV Out Support..... | 34 |
| 2.5.4.4 | Intel [®] 915GM SDVO Support | 34 |
| 2.5.5 | Intel [®] 915GM Direct Media Interface (DMI)..... | 35 |
| 2.6 | INTEL [®] ICH6M SOUTHBRIDGE CHIPSET | 35 |

| | |
|---|-----------|
| 2.6.1 Intel® ICH6M Overview..... | 35 |
| 2.6.2 Intel® ICH6M Audio Codec '97 Controller | 36 |
| 2.6.3 Intel® ICH6M IDE Interface..... | 37 |
| 2.6.4 Intel® ICH6M Low Pin Count (LPC) Interface | 38 |
| 2.6.5 Intel® ICH6M PCI Interface | 38 |
| 2.6.5.1 PCI GbE Ethernet | 38 |
| 2.6.6 Intel® ICH6M Real Time Clock..... | 40 |
| 2.6.7 Intel® ICH6M SATA Controller..... | 40 |
| 2.6.8 Intel® ICH6M USB Controller..... | 40 |
| 2.6.8.1 Intel® ICH6M USB Controller Overview..... | 40 |
| 2.6.8.2 3307740 USB Implementation | 41 |
| 2.6.8.3 Backplane USB Implementation..... | 41 |
| 2.6.9 Intel® ICH6M PCIe Bus Overview | 42 |
| 2.7 LPC BUS COMPONENTS | 42 |
| 2.7.1 LPC Bus Overview..... | 42 |
| 2.7.2 BIOS Chipset..... | 42 |
| 2.7.3 Super I/O chipset..... | 43 |
| 2.7.3.1 Super I/O LPC Interface | 44 |
| 2.7.3.2 Super I/O 16C550 UARTs | 44 |
| 2.7.3.3 Super I/O Enhanced Hardware Monitor | 45 |
| 2.7.3.4 Super I/O Fan Speed Controller..... | 45 |
| 2.7.3.5 Super I/O Parallel Port | 45 |
| 2.7.3.6 Super I/O Keyboard Controller..... | 45 |
| 2.7.4 TPM Connector..... | 46 |
| 2.8 ENVIRONMENTAL AND POWER SPECIFICATIONS | 46 |
| 2.8.1 System Monitoring | 46 |
| 2.8.2 Operating Temperature and Temperature Control..... | 47 |
| 2.8.3 Power Consumption..... | 47 |
| 2.9 EXPANSION OPTIONS | 48 |
| 2.9.1 Expansion Options Overview..... | 48 |
| 2.9.2 GLOBAL AMERICAN Expansion PICMG 1.3 Backplanes..... | 48 |
| 2.9.3 GLOBAL AMERICAN Chassis | 49 |
| 3 UNPACKING | 52 |
| 3.1 ANTI-STATIC PRECAUTIONS | 53 |

| | |
|---|-----------|
| 3.2 UNPACKING..... | 53 |
| 3.2.1 <i>Unpacking Precautions</i> | 53 |
| 3.3 UNPACKING CHECKLIST..... | 54 |
| 3.3.1 <i>Package Contents</i> | 54 |
| 3.3.2 <i>Optional Items</i> | 55 |
| 4 CONNECTOR PINOUTS..... | 58 |
| 4.1 PERIPHERAL INTERFACE CONNECTORS..... | 59 |
| 4.1.1 <i>3307740 Layout</i> | 59 |
| 4.1.2 <i>Peripheral Interface Connectors</i> | 59 |
| 4.1.3 <i>External Interface Panel Connectors</i> | 61 |
| 4.2 INTERNAL PERIPHERAL CONNECTORS..... | 61 |
| 4.2.1 <i>Audio Connector (10-pin)</i> | 61 |
| 4.2.2 <i>Backlight Inverter Connector</i> | 63 |
| 4.2.3 <i>Compact Flash Socket</i> | 64 |
| 4.2.4 <i>Fan Connector (+12V)</i> | 67 |
| 4.2.5 <i>Floppy Disk Connector (34-pin)</i> | 68 |
| 4.2.6 <i>GPIO Connector</i> | 69 |
| 4.2.7 <i>Front Panel Connector (12-pin)</i> | 70 |
| 4.2.8 <i>IDE Connector(40-pin)</i> | 72 |
| 4.2.9 <i>Infrared Interface Connector (5-pin)</i> | 74 |
| 4.2.10 <i>Keyboard Connector</i> | 75 |
| 4.2.11 <i>LVDS LCD Connector</i> | 76 |
| 4.2.12 <i>Mouse Connector</i> | 78 |
| 4.2.13 <i>Parallel Port Connector</i> | 79 |
| 4.2.14 <i>SATA Drive Connectors</i> | 81 |
| 4.2.15 <i>SDVO Connector</i> | 82 |
| 4.2.16 <i>Serial Port Connector (COM1and COM2)</i> | 83 |
| 4.2.17 <i>Trusted Platform Module (TPM) Connector</i> | 84 |
| 4.2.18 <i>TV Out Connector</i> | 86 |
| 4.3 EXTERNAL PERIPHERAL INTERFACE CONNECTOR PANEL..... | 87 |
| 4.3.1 <i>LAN Connectors</i> | 87 |
| 4.3.2 <i>USB Connector</i> | 88 |
| 4.3.3 <i>VGA Connector</i> | 89 |
| 5 INSTALLATION..... | 92 |

| | |
|--|------------|
| 5.1 ANTI-STATIC PRECAUTIONS | 93 |
| 5.2 INSTALLATION CONSIDERATIONS..... | 94 |
| 5.2.1 <i>Installation Notices</i> | 94 |
| 5.2.2 <i>Installation Checklist</i> | 95 |
| 5.3 CPU, CPU COOLING KIT AND DIMM INSTALLATION | 96 |
| 5.3.1 <i>Socket 479 CPU Installation</i> | 96 |
| 5.3.3 <i>DIMM Installation</i> | 99 |
| 5.3.4 <i>CF Card Installation</i> | 100 |
| 5.4 JUMPER SETTINGS | 102 |
| 5.4.1 <i>CF Card Setup</i> | 102 |
| 5.4.2 <i>Clear CMOS Jumper</i> | 103 |
| 5.4.3 <i>FSB Setup Jumper</i> | 105 |
| 5.4.4 <i>LVDS Voltage Selection</i> | 106 |
| 5.5 CHASSIS INSTALLATION..... | 108 |
| 5.5.1 <i>Airflow</i> | 108 |
| 5.5.2 <i>Backplane Installation</i> | 108 |
| 5.5.3 <i>CPU Card Installation</i> | 109 |
| 5.6 INTERNAL PERIPHERAL DEVICE CONNECTIONS..... | 109 |
| 5.6.1 <i>Peripheral Device Cables</i> | 109 |
| 5.6.2 <i>IDE Cable Connection</i> | 110 |
| 5.6.3 <i>5.1 Channel Audio Kit Installation</i> | 111 |
| 5.6.4 <i>7.1 Channel Audio Kit Installation</i> | 112 |
| 5.6.5 <i>FDD Cable Connection</i> | 114 |
| 5.6.6 <i>Parallel Port Cable</i> | 115 |
| 5.6.7 <i>Dual RS-232 Cable Connection</i> | 117 |
| 5.6.8 <i>SATA Drive Connection</i> | 118 |
| 5.6.9 <i>Wafer-to-PS/2 Cable (Keyboard/Mouse Installation)</i> | 120 |
| 5.7 EXTERNAL PERIPHERAL INTERFACE CONNECTION | 121 |
| 5.7.1 <i>LAN Connection (Single Connector)</i> | 121 |
| 5.7.2 <i>USB Device Connection (Single Connector)</i> | 122 |
| 5.7.3 <i>VGA Monitor Connection</i> | 123 |
| A DIO INTERFACE..... | 125 |
| A.1 DIO INTERFACE INTRODUCTION | 126 |
| A.2 DIO CONNECTOR PINOUTS | 126 |

| | |
|---|------------|
| A.3 ASSEMBLY LANGUAGE SAMPLES | 127 |
| <i>A.3.1 Enable the DIO Input Function</i> | 127 |
| <i>A.3.2 Enable the DIO Output Function</i> | 127 |
| B WATCHDOG TIMER | 129 |
| C ADDRESS MAPPING | 133 |
| C.1 ADDRESS MAP | 134 |
| C.2 1ST MB MEMORY ADDRESS MAP | 134 |
| C.3 IRQ MAPPING TABLE | 135 |
| C.4 DMA CHANNEL ASSIGNMENTS | 135 |

List of Figures

| | |
|--|----|
| Figure 1-1: 3307740 Overview [Front View] | 21 |
| Figure 2-1: 3307740 Dimensions (mm)..... | 26 |
| Figure 2-2: External Interface Panel Dimensions (mm)..... | 27 |
| Figure 2-3: Data Flow Block Diagram | 28 |
| Figure 2-4: 240-pin DDR2 DIMM Socket | 31 |
| Figure 2-5: PCIe x16 Golden Fingers..... | 31 |
| Figure 2-6: Realtek PCI GbE Controllers..... | 39 |
| Figure 2-7: Onboard USB Implementation | 41 |
| Figure 2-8: IUSB Golden Finger | 41 |
| Figure 2-9: PCIe x4 Golden finger | 42 |
| Figure 2-10: BIOS Chipset | 43 |
| Figure 2-11: Super I/O Chipset | 44 |
| Figure 4-1: Connector and Jumper Locations..... | 59 |
| Figure 4-2: Audio Connector Pinouts (10-pin)..... | 62 |
| Figure 4-3: Panel Backlight Connector Pinout Locations | 63 |
| Figure 4-4: CF Card Socket Location | 65 |
| Figure 4-5: +12V Fan Connector Location | 67 |
| Figure 4-6: 34-pin FDD Connector Location | 68 |
| Figure 4-7: GPIO Connector Pinout Locations..... | 70 |
| Figure 4-8: Front Panel Connector Pinout Locations | 71 |
| Figure 4-9: Secondary IDE Device Connector Locations | 73 |
| Figure 4-10: Infrared Connector Pinout Locations | 74 |
| Figure 4-11: Keyboard Connector Location..... | 76 |
| Figure 4-12: LVDS LCD Connector Pinout Locations | 77 |
| Figure 4-13: Mouse Connector Location..... | 78 |
| Figure 4-14: Parallel Port Connector Location | 80 |
| Figure 4-15: SATA Drive Connector Locations | 81 |
| Figure 4-16: SDVO Connector Pinout Locations..... | 82 |
| Figure 4-17: COM1 and COM2 Connector Pinout Locations | 84 |
| Figure 4-18: TPM Connector Pinout Locations | 85 |
| Figure 4-19: TV Connector Pinout Locations | 86 |

| | |
|--|-----|
| Figure 4-20: 3307740 External Peripheral Interface Connector | 87 |
| Figure 4-21: RJ-45 Ethernet Connector | 88 |
| Figure 4-22: VGA Connector | 89 |
| Figure 5-1: Make sure the CPU socket retention screw is unlocked | 97 |
| Figure 5-2: Lock the CPU Socket Retention Screw | 98 |
| Figure 5-6: Installing a DIMM | 99 |
| Figure 5-7: CF Card Installation | 101 |
| Figure 5-8: Jumper Locations | 102 |
| Figure 5-9: CF Card Setup Jumper Location | 103 |
| Figure 5-10: Clear CMOS Jumper | 105 |
| Figure 5-11: FSB Setup Jumper Jumper | 106 |
| Figure 5-12: LVDS Voltage Selection Jumper Pinout Locations | 107 |
| Figure 5-13: IDE Cable Connection | 110 |
| Figure 5-14: 5.1 Channel Audio Kit | 112 |
| Figure 5-15: 5.1 Channel Audio Kit | 113 |
| Figure 5-16: FDD Cable Connection | 115 |
| Figure 5-17: LPT Cable Connection | 116 |
| Figure 5-18: Connect the LPT Device | 117 |
| Figure 5-19: Dual RS-232 Cable Installation | 118 |
| Figure 5-20: SATA Drive Cable Connection | 119 |
| Figure 5-21: SATA Power Drive Connection | 120 |
| Figure 5-22: Keyboard/mouse Cable Connection | 120 |
| Figure 5-23: LAN Connection | 122 |
| Figure 5-24: USB Device Connection | 123 |
| Figure 5-25: VGA Connector | 124 |

List of Tables

| | |
|--|----|
| Table 1-1: Technical Specifications | 24 |
| Table 2-1: Supported Processors | 29 |
| Table 2-2: Supported HDD Specifications | 37 |
| Table 2-3: Power Consumption | 48 |
| Table 2-4: Compatible GLOBAL AMERICAN PICMG 1.3 Backplanes | 49 |
| Table 2-5: Compatible GLOBAL AMERICAN Chassis | 51 |
| Table 3-1: Package List Contents | 55 |
| Table 3-2: Optional Items | 57 |
| Table 4-1: Peripheral Interface Connectors | 60 |
| Table 4-2: Rear Panel Connectors | 61 |
| Table 4-3: Audio Connector Pinouts (10-pin)..... | 62 |
| Table 4-4: Panel Backlight Connector Pinouts | 64 |
| Table 4-5: CF Card Socket Pinouts | 66 |
| Table 4-6: +12V Fan Connector Pinouts | 68 |
| Table 4-7: 34-pin FDD Connector Pinouts | 69 |
| Table 4-8: GPIO Connector Pinouts | 70 |
| Table 4-9: Front Panel Connector Pinouts | 72 |
| Table 4-10: Secondary IDE Connector Pinouts | 74 |
| Table 4-11: Infrared Connector Pinouts..... | 75 |
| Table 4-12: Keyboard Connector Pinouts | 76 |
| Table 4-13: LVDS LCD Port Connector Pinouts | 78 |
| Table 4-14: Mouse Connector Pinouts | 79 |
| Table 4-15: Parallel Port Connector Pinouts | 80 |
| Table 4-16: SATA Drive Connector Pinouts..... | 82 |
| Table 4-17: SDVO Pinouts | 83 |
| Table 4-18: COM1 and COM2..... | 84 |
| Table 4-19: TPM Connector Pinouts | 86 |
| Table 4-20: TV OutConnector Pinouts | 87 |
| Table 4-21: LAN Pinouts..... | 88 |
| Table 4-22: RJ-45 Ethernet Connector LEDs | 88 |
| Table 4-23: USB Port Pinouts | 89 |

| | |
|---|------------|
| Table 4-24: VGA Connector Pinouts | 90 |
| Table 5-1: Jumpers | 102 |
| Table 5-2: CF Card Setup Jumper Settings..... | 103 |
| Table 5-3: Clear CMOS Jumper Settings..... | 104 |
| Table 5-4: FSB Setup Jumper Settings..... | 106 |
| Table 5-5: LVDS Voltage Selection Jumper Settings..... | 107 |
| Table 5-6: GLOBAL AMERICAN Provided Cables | 109 |

Glossary

| | | | |
|--------|--|-----------|---|
| AC '97 | Audio Codec 97 | HDD | Hard Disk Drive |
| ACPI | Advanced Configuration and Power Interface | IDE | Integrated Data Electronics |
| APM | Advanced Power Management | I/O | Input/Output |
| ARMD | ATAPI Removable Media Device | ICH4 | I/O Controller Hub 4 |
| ASKIR | Shift Keyed Infrared | L1 Cache | Level 1 Cache |
| ATA | Advanced Technology Attachments | L2 Cache | Level 2 Cache |
| BIOS | Basic Input/Output System | LCD | Liquid Crystal Display |
| CFII | Compact Flash Type 2 | LPT | Parallel Port Connector |
| CMOS | Complementary Metal Oxide Semiconductor | LVDS | Low Voltage Differential Signaling |
| CPU | Central Processing Unit | MAC | Media Access Controller |
| Codec | Compressor/Decompressor | OS | Operating System |
| COM | Serial Port | PCI | Peripheral Connect Interface |
| DAC | Digital to Analog Converter | PIO | Programmed Input Output |
| DDR | Double Data Rate | PnP | Plug and Play |
| DIMM | Dual Inline Memory Module | POST | Power On Self Test |
| DIO | Digital Input/Output | RAM | Random Access Memory |
| DMA | Direct Memory Access | SATA | Serial ATA |
| EIDE | Enhanced IDE | S.M.A.R.T | Self Monitoring Analysis and Reporting Technology |
| EIST | Enhanced Intel SpeedStep Technology | SPD | Serial Presence Detect |
| FDD | Floppy Disk Drive | S/PDI | Sony/Philips Digital Interface |
| FDC | Floppy Disk Connector | SDRAM | Synchronous Dynamic Random Access Memory |
| FFIO | Flexible File Input/Output | SIR | Serial Infrared |
| FIFO | First In/First Out | UART | Universal Asynchronous Receiver-transmitter |
| FSB | Front Side Bus | USB | Universal Serial Bus |
| IrDA | Infrared Data Association | VGA | Video Graphics Adapter |

Chapter

1

Introduction

1.1 Introduction

The 3307740 PICMG 1.3 CPU card is a Socket 479 Intel® Pentium® M or Intel® Celeron® M CPU platform. The 3307740 has a maximum front side bus (FSB) frequency of 533MHz and supports two 533MHz 1GB dual channel DDR2 memory modules. The 3307740 also comes with dual PCI Express (PCIe) Gigabit Ethernet (GbE) and has flexible storage options including support for two serial ATA (SATA) hard disk drives (HDD), two IDE HDD, a CompactFlash® Type II (CF Type II) disk, and a floppy disk drive (FDD). Optional v1.2 Trusted Platform Modules (TPM) are available as plug-in devices to further ensure system security.

A 3307740 CPU card (3307740) with a preinstalled 600MHz Intel® Celeron® M CPU with a 512K L2 cache is also available.

1.1.1 3307740 Benefits

Some of the 3307740 benefits are listed below:

- Multiple display output options
- Storage flexibility with support for SATA drives, IDE drives and CF Type II disks
- DDR2 support enables faster data transfers
- Multiple I/O interfaces provide connectivity to a broad range of external peripheral devices
- Optional TPMs for secure system bootup

1.1.2 3307740 Features

Some of the 3307740 features are listed below.

- Support for the following Socket 479 processors:
 - Intel® Pentium® M
 - Intel® Celeron® M
- Maximum FSB of 533MHz
- Maximum of 2GB dual-channel memory supported with two 240-pin dual channel 400MHz or 533MHz 1GB DDR2 DIMMs

3307740 PICMG 1.3 CPU Card

- Two SATA drives with transfer rates of 1.5Gb/s supported
- High performance PCIe GbE Ethernet controllers
- Two USB 2.0 devices supported
- Multiple display options including CRT, 18-bit dual-channel LVDS and HDTV
- PICMG 1.3 form factor
- RoHS compliant

1.2 3307740 Overview

1.2.1 3307740 Overview Photo

The 3307740 has a wide variety of internal and external peripheral connectors. A labeled photo of the peripheral connectors on the front of the 3307740 is shown in **Figure 1-1**.

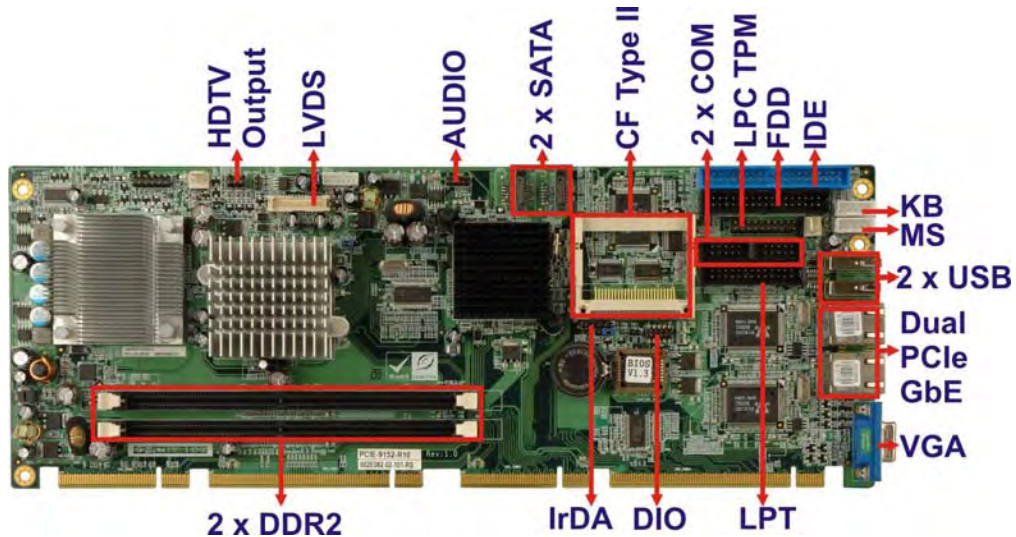

Figure 1-1: 3307740 Overview [Front View]

1.2.2 3307740 Peripheral Connectors and Jumpers

The 3307740 has the following connectors on-board:

- 1 x Audio connector
- 1 x Compact flash connector
- 2 x Fan connectors
- 1 x Floppy disk drive (FDD) connector
- 1 x Front panel connector

3307740 PICMG 1.3 CPU Card

- 1 x 8-bit general purpose Input/output (GPIO) connector
- 1 x IDE disk drive connector
- 1 x Infrared interface connector
- 1 x Inverter connector
- 1 x Keyboard connector
- 1 x LVDS connector
- 1 x Mouse connector
- 2 x Serial port connectors (internal COM 1 and COM 2 RS-232)
- 2 x Serial ATA (SATA) drive connectors
- 1 x Serial digital video out (SDVO) connector
- 1 x TPM connector
- 1 x TV output connector

The 3307740 has the following external peripheral interface connectors on the board rear panel

- 2 x Ethernet connectors
- 2 x USB port connectors
- 1 x VGA connector

The 3307740 has the following on-board jumpers:

- Clear CMOS
- FSB select
- LCD voltage selector
- CF card setting

1.2.3 Technical Specifications

3307740 technical specifications are listed in **Table 1-1**. See **Chapter 2** for details.

| Specification | 3307740 |
|---------------|--|
| Form Factor | PICMG 1.3 |
| System CPU | Socket 479 Intel® Pentium® M Socket 479 Intel® Celeron® M |

3307740 PICMG 1.3 CPU Card

| Specification | 3307740 |
|-------------------|--|
| Front Side Bus | 400MHz or 533Mhz |
| System Chipset | Northbridge: Intel® 915GM Southbridge: Intel® ICH6M |
| Memory | Two 240-pin DIMM sockets support two dual-channel 400MHz or 533MHz DDR2 DIMMs with a maximum capacity of 1GB each |
| Display | CRT: Integrated in the Intel® 915GM to support CRT LVDS: Dual channel 18-bit LVDS LCD panel HDTV: Supports resolutions up to 1080i / 1080P by component interface |
| BIOS | AMI Flash BIOS |
| Audio | 7.1 channel or 5.1 channel audio with an optional AC-KIT |
| LAN | Dual PCIe GbE Realtek RTL8110SC chipsets |
| COM | Two RS-232 serial ports |
| USB2.0 | Two USB 2.0 devices supported |
| IDE | One 40-pin IDE connects to two Ultra ATA33/66/100 devices |
| Floppy Disk Drive | One FDD connector connects to a single FDD |
| SATA | Two 1.5Gb/s SATA drives supported |
| Keyboard/mouse | One 5-pin connector connects to a keyboard One 5-pin connector connects to a mouse |
| Super I/O | ITE IT8712F |
| Digital I/O | One 8-bit digital I/O connector (4-bit input / 4-bit output) |
| Infrared | One Infrared connector |

3307740 PICMG 1.3 CPU Card

| Specification | 3307740 |
|----------------------|---|
| SSD | CF Type II |
| Watchdog Timer | Software programmable 1-255 sec. by super I/O |
| Power Supply | ATX supported |
| Temperature | 0°C – 60°C (32°F - 140°F) |
| Humidity (operating) | 5%~95% non-condensing |
| Dimensions (LxW) | 338.58mm x 126.39mm |
| Weight (GW/NW) | 1100g/ 380g |

Table 1-1: Technical Specifications

Chapter

2

Detailed Specifications

2.1 Overview

This chapter describes the specifications and on-board features of the 3307740 in detail.

2.2 Dimensions

2.2.1 Board Dimensions

The dimensions of the board are listed below:

- **Length:** 338.58mm
- **Width:** 126.39mm

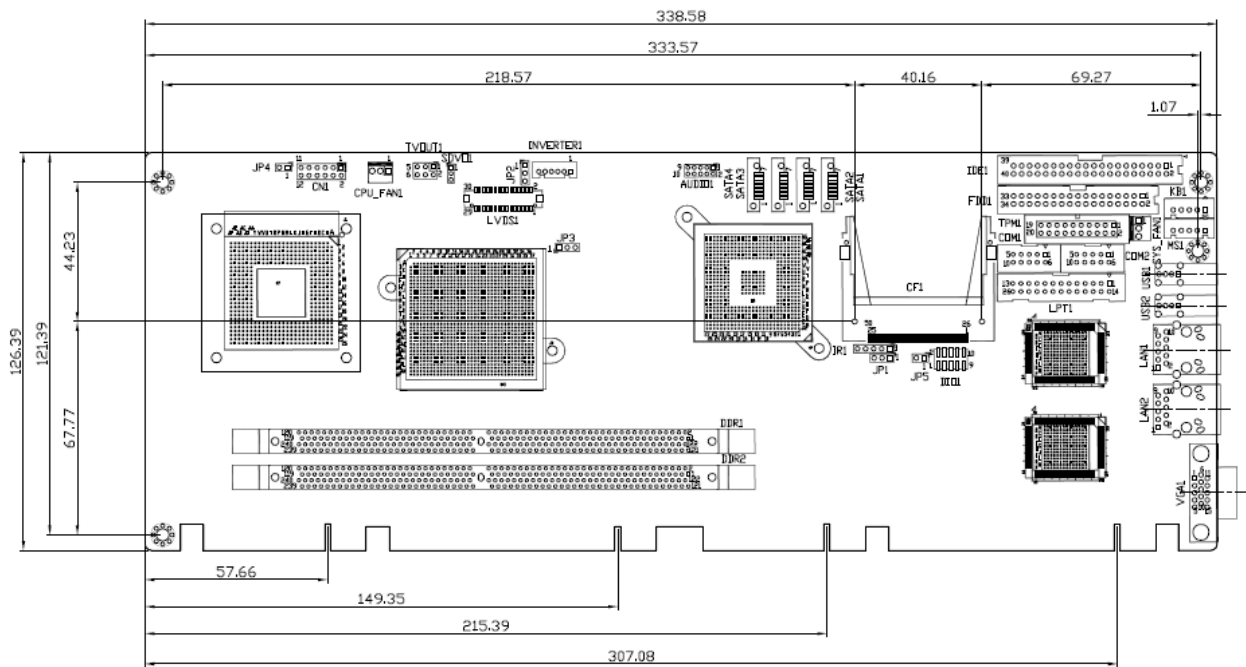

Figure 2-1: 3307740 Dimensions (mm)

2.2.2 External Interface Panel Dimensions

External peripheral interface connector panel dimensions are shown in **Figure 2-2**.

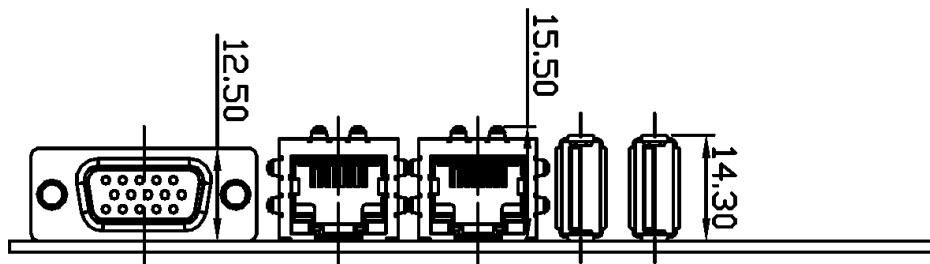

Figure 2-2: External Interface Panel Dimensions (mm)

2.3 Data Flow

Figure 2-3 shows the data flow between the two on-board chipsets and other components installed on the motherboard and described in the following sections of this chapter.

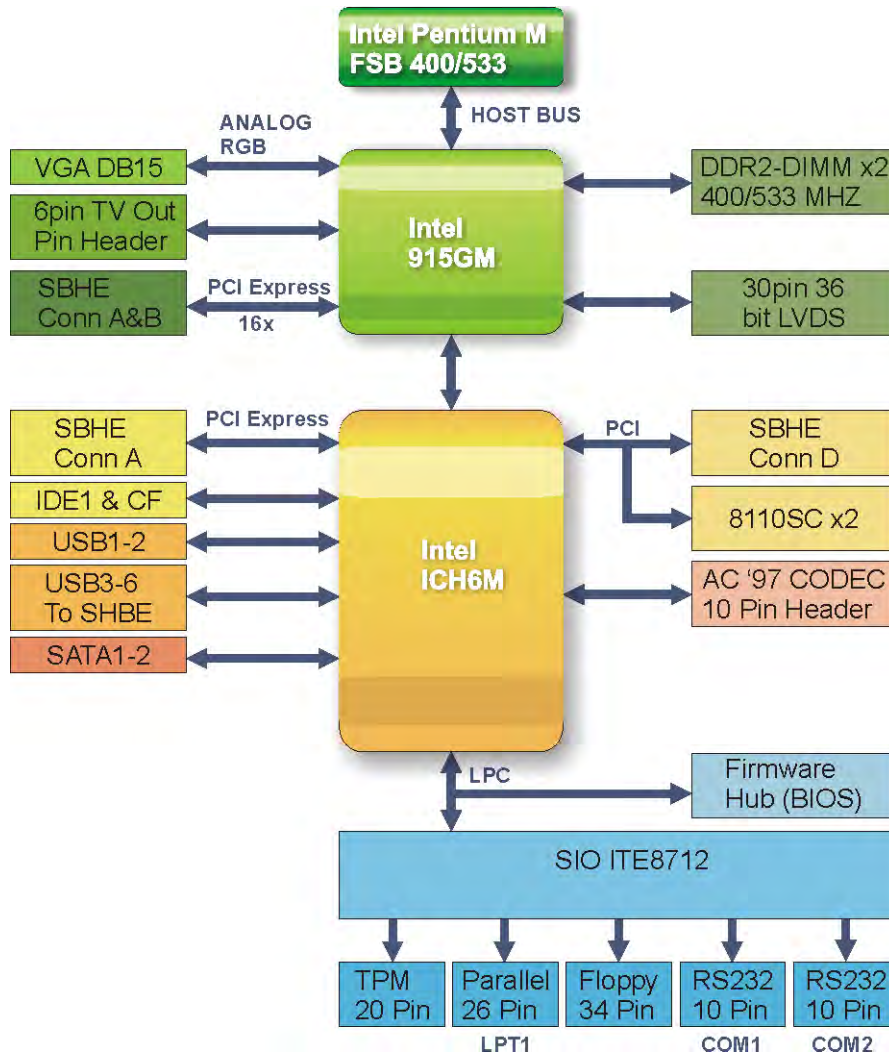

Figure 2-3: Data Flow Block Diagram

2.4 Compatible Processors

2.4.1 Compatible Processor Overview

The 3307740 supports the following socket 479 processors:

- Intel® Pentium® M processors
- Intel® Celeron® M processors

3307740 PICMG 1.3 CPU Card

All the above processors communicate with the Intel[®] 915GM northbridge chipset through a 533MHz or 400MHz front side bus (FSB). Compatible processors are listed in **Table 2-1**.

| Family | CPU Speed | Processor # | Bus Speed | Mfg Tech | Stepping | Cache Size |
|------------------------|-----------|-------------|-----------|-------------|----------|------------|
| Pentium [®] M | 2.13 GHz | 770 | 533 MHz | 90 nm | C0 | 2 MB |
| | 2.10 GHz | N/A | 400 MHz | 90 nm | B1 | 2 MB |
| | 2 GHz | 760 | 533 MHz | 90 nm | C0 | 2 MB |
| | 1.86 GHz | 750 | 533 MHz | 90 nm | C0 | 2 MB |
| | 1.73 GHz | 740 | 533 MHz | 90 nm | C0 | 2 MB |
| | 1.60 GHz | 778 | 400 MHz | 90 nm | C0 | 2 MB |
| | 1.60 GHz | 730 | 533 MHz | 90 nm | C0 | 2 MB |
| | 1.40 GHz | N/A | 400 MHz | 90 nm | B0 | 2 MB |
| | 1.10 GHz | N/A | 400 MHz | 90 nm | B1 | 2 MB |
| Celeron [®] M | 1.40 GHz | 360 | 400 MHz | 90 nm | B1 | 1 MB |
| | 1.30 GHz | 350 | 400 MHz | 90 nm | B1 | 1 MB |
| | 1.30 GHz | 320 | 400 MHz | 0.13 micron | B1 | 512 KB |
| | 1.30 GHz | 350 | 400 MHz | 90 nm | B1 | 1 MB |
| | 1.20 GHz | 310 | 400 MHz | 0.13 micron | B1 | 512 KB |
| | 1 GHz | N/A | 400 MHz | 90 nm | C0 | 1 MB |
| | 900 MHz | 353 | 400 MHz | 90 nm | B1 | 512 KB |

Table 2-1: Supported Processors

2.5 Intel[®] 915GM Northbridge Chipset

2.5.1 Intel[®] 915GM Overview

The Intel[®] 915GM northbridge chipset has the Generation 3.1 Intel Integrated Graphics Engine and the Intel[®] Graphics Media Accelerator 950 (Intel[®] GMA 950). The integrated graphics and memory controller hub (GMCH) facilitates the flow of information primarily between the following four interfaces:

- Front Side Bus (FSB)
- System Memory Interface
- Graphics Interface
- Direct Media Interface (DMI)

2.5.2 Intel® 915GM Memory Support



WARNING:

Only DDR2 memory module can be installed on the 3307740. Do not install DDR memory modules. If a DDR memory module is installed on the 3307740, the 3307740 may be irreparably damaged.

The Intel® 915GM northbridge chipset on the 3307740 supports two DDR2 240-pin DIMMs with the following features:

- Two 240-pin DIMMs
- DDR2 only (**DO NOT** install a DDR DIMM)
- 64-bit wide
- Single-channel or dual-channel
- Capacities of 256MB, 512MB, 1GB or 2GB
- Transfer speeds of 400MHz, 533MHz or 667MHz
- 64-bit wide channel

The memory socket is shown in **Figure 2-4**.

3307740 PICMG 1.3 CPU Card

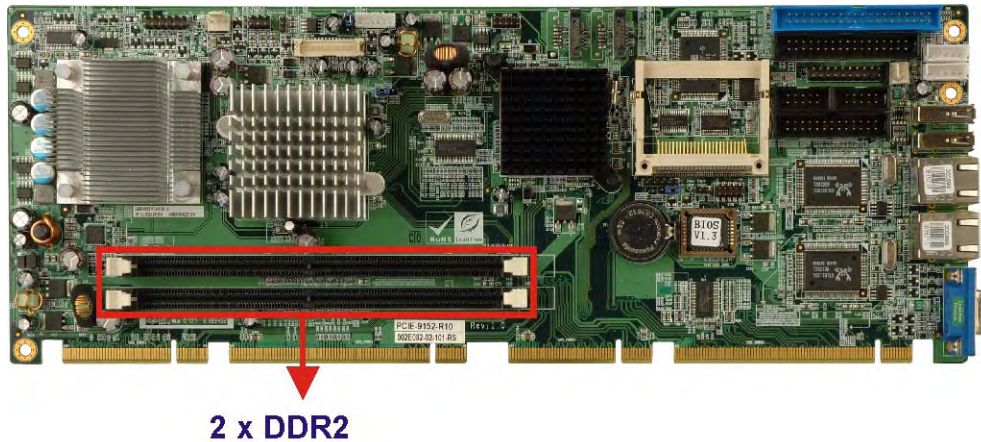

Figure 2-4: 240-pin DDR2 DIMM Socket

2.5.3 Intel® 915GM PCIe x16

2.5.3.1 PCIe x16 Bus Overview

The Intel® 915GM northbridge chipset has a dedicated 16-lane PCIe port for an external PCIe x16 graphics card. The PCIe x16 graphics card is installed on a compatible PICMG 1.3 backplane and interfaced to the northbridge through the two golden fingers shown in **Figure 2-5**. Note that the 16 lanes of the PCIe x16 northbridge bus are connected to two golden fingers.

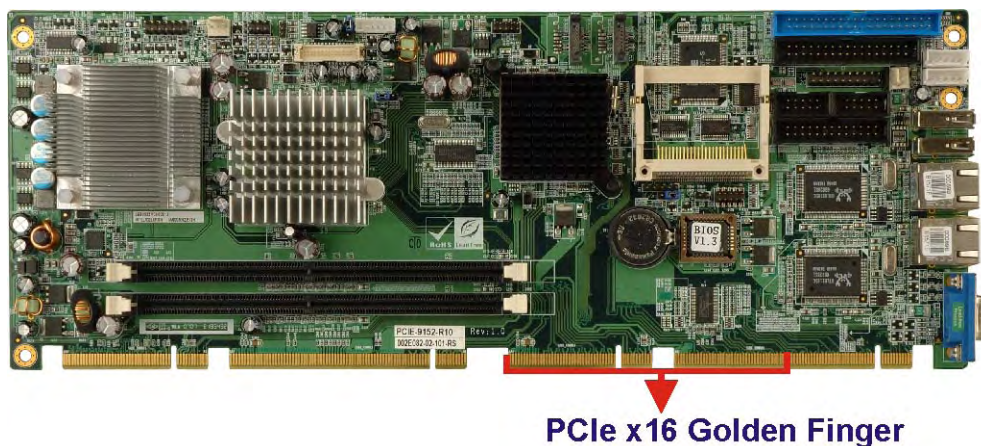

Figure 2-5: PCIe x16 Golden Fingers

2.5.3.2 PCIe x16 Expansion Options

The PCIe x16 can be interfaced to either one PCIe x16 graphics card or a single PCIe x1 expansion card on a compatible PICMG 1.3 backplane.

2.5.3.3 PCIe x16 Bus Specifications

Some of the PCIe x16 bus specifications are listed below.

- Compliant with the current PCI Express Base Specification base PCIe frequency of 2.5GHz
- Raw bit rate on the pins is 250Gb/s
- Maximum theoretical bandwidth of 4GB/s in each direction resulting in an 8GB/s bandwidth when in PCIe x16 mode
- 100MHz differential reference clock
- PCIe power management support
- L0, L1, L2/L3 ready, L3
- Hierarchical PCI compliant configuration mechanism for downstream components
- PCIe extended configuration space
- PCIe enhanced addressing mechanism
- Supports traditional PCI traffic
- Supports traditional AGP traffic
- APIC and MSI messaging support

2.5.4 Intel® 915GM Integrated Graphics

The Intel® 915GM northbridge chipset has an integrated graphics engine that supports the following display devices:

- Analog CRT
- Digital LVDS
- TV-Out
- S-DVO ports

2.5.4.1 Intel® 915GM Analog CRT Support

A DB-15 VGA connector on the external peripheral interface connector panel is interfaced to the Intel® 915GM graphics engine. The Intel® 915GM internal graphics engine, with an integrated 400MHz RAMDAC and hot plug CRT support, supports analog CRT monitors with the following features:

- Supports max DAC frequency up to 400 MHz
- 24-bit RAMDAC support
- DDC2B compliant
- Up to 2048 x 1536 mode support

2.5.4.2 Intel® 915GM LVDS Support

A 30-pin LVDS crimp connector is interfaced to the Intel® 915GM graphics engine. The Intel® 915GM internal graphics engine supports LVDS displays with the following features:

- Compliant with ANSI/TIA/EIA -644-2001 spec
- Integrated dual channel LVDS interface supported on Display Pipe B only
- Supports 25 to 112 MHz single/dual channel LVDS interface
 - Single channel LVDS interface support: 1 x 18 bpp
 - Dual channels LVDS interface support: 2 x 18 bpp
- TFT panel type supported
- Maximum Panel size supported up to UXGA
- Maximum Wide panel size supported up to WUXGA
- Ambient Light Sense support for automatic backlight brightness adjustments
- Intel Display Power Savings Technology 2.0 support
- Supports Single pipe simultaneous display with the CRT DAC and the LVDS ports under the following conditions:
 - Timings must match for both display
- Panel Fitting. Panning, and Center mode supported
- Spatial Dithering support to emulate up to 16 million colors for 18bpp TFT panels
- Spread spectrum clocking (SSC) supported

- Supports down and center SSC via an SSC clock from an external SSC clock chip.
- Supports down spread of – 2.5% or center spread of \pm -1.25% in reference 30-50 kHz modulation rate
- SSC must be disabled for LVDS port and CRT DAC single pipe simultaneous display mode.
- Panel Power Sequencing support
 - Power down state can be either zero volt or high impedance
- Integrated PWM interface for LCD Backlight Inverter Control
- Up to UXGA monitors with a maximum resolution of 1600 x 1200
- 18-bit 25MHz to 112MHz single-channel or dual-channel LVDS screens
- CPIS 1.5 compliant LVDS screens

2.5.4.3 Intel® 915GM TV Out Support

A 6-pin TV output connector is interfaced to the Intel® 915GM graphics engine. The Intel® 915GM internal graphics engine has the following TV output features:

- Integrated TV-out device supported on Display pipe A and pipe B.
- Three Integrated 10 bit DAC
- NTSC/PAL encoder standard formats supported
- Up to 1024x768 resolution supported for NTSC/PAL
- HDTV graphics resolutions support
- 480p/720p/1080i/1080p modes supported
- Multiplexed Output interface:
 - Composite Video
 - S-Video
 - Component Video (YprPb)
 - Combination: (Composite & S-Video)
- Macrovision support
- Overscan Scaling Support

2.5.4.4 Intel® 915GM SDVO Support

The Intel® 915GM internal graphics engine has the following SDVO output features:

3307740 PICMG 1.3 CPU Card

- Two SDVO ports are supported
- Supports a variety display devices such as DVI, TV Out, LVDS, etc.
- Compliant with DVO specification 1.0 when combined with a DVI compliant external device and connector.
- Data sourced from either display Pipe A or Pipe B
- Supports single pipe simultaneous display with the DAC or LVDS ports
- Timings must match for both display
- Single pipe not supported with SSC on LVDS port
- Each SDVO Port support display pixel rates up to 200 MP/s (600MB/s)
- Fast point-to-point GMBUS is provided for SDVO device control
- Supports Hot Plug and Display
- Support for HDCP SDVO devices

2.5.5 Intel® 915GM Direct Media Interface (DMI)

Intel® 915GM northbridge GMCH is connected to the Intel® ICH6M Southbridge Chipset through the chip-to-chip Direct Media Interface (DMI). Features of the Intel® 915GM DMI are listed below:

- Chip-to-chip interface between GMCH and ICH6M
- Configurable as x2 or x4 DMI lanes
- 2 GB/s point-to-point DMI to ICH6M (1 GB/s each direction)
- 100 MHz reference clock (shared with PCI Express Graphics Attach).
- 32-bit downstream addressing
- APIC and MSI interrupt messaging support.
- Message Signaled Interrupt (MSI) messages
- SMI, SCI and SERR error indication

2.6 Intel® ICH6M Southbridge Chipset

2.6.1 Intel® ICH6M Overview

The Intel® ICH6M southbridge chipset is connected to the Intel® 915GM northbridge GMCH through the chip-to-chip Direct Media Interface (DMI). Some of the features of the Intel® ICH6M are listed below.

- Complies with PCI Express Base Specification, Revision 1.0a
- Complies with PCI Local Bus Specification, Revision 2.3 and supports 33MHz PCI operations
- Supports ACPI Power Management Logic
- Contains:
 - Enhanced DMA controller
 - Interrupt controller
 - Timer functions
- Integrated SATA host controller with DMA operations interfaced to two SATA connectors on the 3307740
- Integrated IDE controller supports Ultra ATA 100/66/33
- Supports the four USB 2.0 devices on the 3307740 with four UHCI controllers and one EHCI controller
- Complies with System Management Bus (SMBus) Specification, Version 2.0
- Supports Audio Codec '97 (AC'97) Revision 2.3
- Supports Intel® High Definition Audio
- Contains Low Pin Count (LPC) interface
- Supports Firmware Hub (FWH) interface

2.6.2 Intel® ICH6M Audio Codec '97 Controller

The Audio Codec '97 (AC'97) controller integrated into the ICH6M complies with AC'97 Component Specification, Version 2.3. The AC'97 controller is connected to the onboard audio connector. The audio connector is connected to an optional 5.1 channel or 7.1 channel audio kit with an embedded AC'97 audio codec. The AC'97 controller supports up to six PCM audio output channels. Complete surround sound requires six-channel audio consisting of:

- Front left
- Front right
- Back left
- Back right
- Center
- Subwoofer

2.6.3 Intel® ICH6M IDE Interface

The integrated IDE interface on the ICH6M southbridge supports two IDE hard disks and ATAPI devices. PIO IDE transfers up to 16MB/s and Ultra ATA transfers of 100MB/s. The integrated IDE interface is able to support the following IDE HDDs:

- **Ultra ATA/100**, with data transfer rates up to 100MB/s
- **Ultra ATA/66**, with data transfer rates up to 66MB/s
- **Ultra ATA/33**, with data transfer rates up to 33MB/s

| Specification | Ultra ATA/100 | Ultra ATA/66 | Ultra ATA/33 |
|-----------------------|---------------|--------------|--------------|
| IDE devices | 2 | 2 | 2 |
| PIO Mode | 0 – 4 | 0 – 4 | 0 – 4 |
| PIO Max Transfer Rate | 16.6 MB/s | 16.6 MB/s | 16.6 MB/s |
| DMA/UDMA designation | UDMA 3 - 4 | UDMA 3 – 4 | UDMA 2 |
| DMA/UDMA Max Transfer | 100MB/s | 66MB/s | 33MB/s |
| Controller Interface | 5V | 5V | 5V |

Table 2-2: Supported HDD Specifications

2.6.4 Intel® ICH6M Low Pin Count (LPC) Interface

The ICH6M LPC interface complies with the LPC 1.1 specifications. The LPC bus from the ICH6M is connected to the following components:

- BIOS chipset
- Super I/O chipset

2.6.5 Intel® ICH6M PCI Interface

The PCI interface on the ICH6M is compliant with the PCI Revision 2.3 implementation. Some of the features of the PCI interface are listed below.

- PCI Revision 2.3 compliant
- 33MHz
- 5V tolerant PCI signals (except PME#)
- Integrated PCI arbiter supports up to seven PCI bus masters

The PCI bus is connected to an interface gold finger on the bottom of the CPU card and supports four expansion PCI cards on the backplane.

2.6.5.1 PCI GbE Ethernet

Two PCI lanes are connected to two Realtek RTL8110SC GbE controllers shown in **Figure 2-6** below.

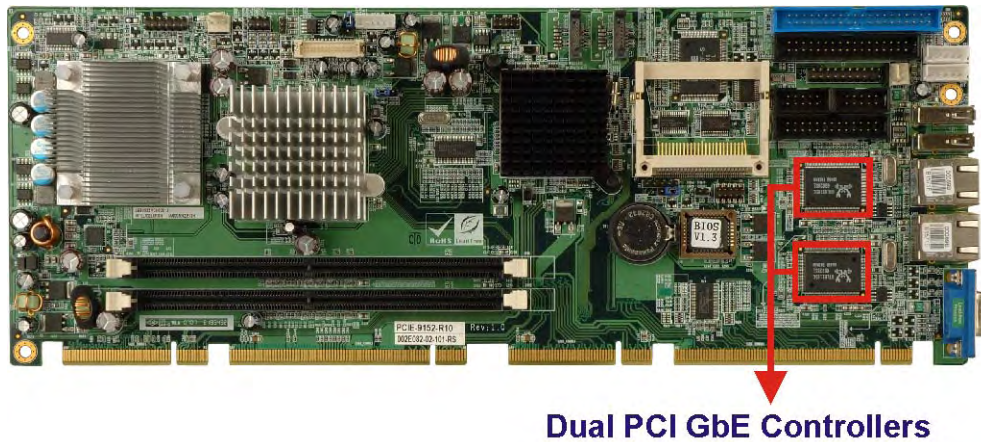

Figure 2-6: Realtek PCI GbE Controllers

The Realtek RTL8110SC PCI GbE controllers combine a triple-speed IEEE 802.3 compliant Media Access Controller (MAC) with a triple-speed Ethernet transceiver, 32-bit PCI bus controller, and embedded memory. With state-of-the-art DSP technology and mixed-mode signal technology, they offer high-speed transmission over CAT 5 UTP cable or CAT 3 UTP (10Mbps only) cable. Functions such as Crossover Detection & Auto-Correction, polarity correction, adaptive equalization, cross-talk cancellation, echo cancellation, timing recovery, and error correction are implemented to provide robust transmission and reception capability at high speeds.

Some of the features of the Realtek RTL8110SC PCI GbE controllers are listed below.

- Integrated 10/100/1000 transceiver
- Auto-Negotiation with Next Page capability
- Supports PCI rev.2.3, 32-bit, 33/66MHz
- Supports pair swap/polarity/skew correction
- Crossover Detection & Auto-Correction
- Wake-on-LAN and remote wake-up support
- Microsoft® NDIS5 Checksum Offload (IP, TCP, UDP) and largesend offload support
- Supports Full Duplex flow control (IEEE 802.3x)
- Fully compliant with IEEE 802.3, IEEE 802.3u, IEEE 802.3ab
- Supports IEEE 802.1P Layer 2 Priority Encoding

- Supports IEEE 802.1Q VLAN tagging
- Serial EEPROM
- 3.3/1.8/1.5V signaling, 5V PCI I/O tolerant
- 0.15µm CMOS process
- Transmit/Receive FIFO (8K/64K) support
- Supports power down/link down power saving
- Supports PCI Message Signaled Interrupt (MSI)

2.6.6 Intel® ICH6M Real Time Clock

256 bytes of battery backed RAM is provided by the Motorola MC146818A real time clock (RTC) integrated into the ICH6M. The RTC operates on a 3V battery and 32.768KHz crystal. The RTC keeps track of the time and stores system data even when the system is turned off.

2.6.7 Intel® ICH6M SATA Controller

The integrated SATA controller on the ICH6M southbridge supports two SATA drives on the 3307740 with independent DMA operations. SATA controller specifications are listed below.

- Supports two SATA drives
- Supports 1.5Gb/s data transfer speeds
- Supports Serial ATA Specification, Revision 1.0a

2.6.8 Intel® ICH6M USB Controller

2.6.8.1 Intel® ICH6M USB Controller Overview

Up to eight high-speed, full-speed or low-speed USB devices are supported by the ICH6M on the 3307740. High-speed USB 2.0, with data transfers of up to 480MB/s, is enabled with the ICH6M integrated Enhanced Host Controller Interface (EHCI) compliant host controller. USB full-speed and low-speed signaling is supported by the ICH6M integrated Universal Host Controller Interface (UHCI) controllers.

3307740 PICMG 1.3 CPU Card

2.6.8.2 3307740 USB Implementation

Two of the Intel® ICH6M USB ports are implemented on the 3307740. The two ports are connected to two external connectors. See **Figure 2-7**.

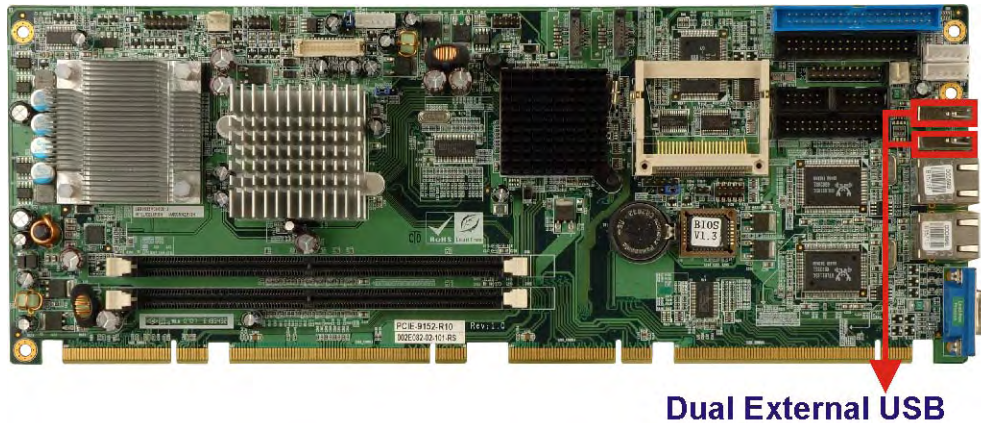

Figure 2-7: Onboard USB Implementation

2.6.8.3 Backplane USB Implementation

Four of the remaining six Intel® ICH6M USB ports are interfaced to the backplane through a golden finger on the bottom of the CPU card. See **Figure 2-8**. These four USB ports can be implemented through connectors on the backplane.



Figure 2-8: IUSB Golden Finger

2.6.9 Intel® ICH6M PCIe Bus Overview

The Intel® ICH6M southbridge chipset has four PCIe x1 lanes. The four PCIe x1 lanes are interfaced through a golden finger on the bottom of the CPU card through the backplane to either four PCIe x1 expansion cards or one PCIe x4 expansion card. The PCIe x4 golden finger is shown in **Figure 2-9** below.

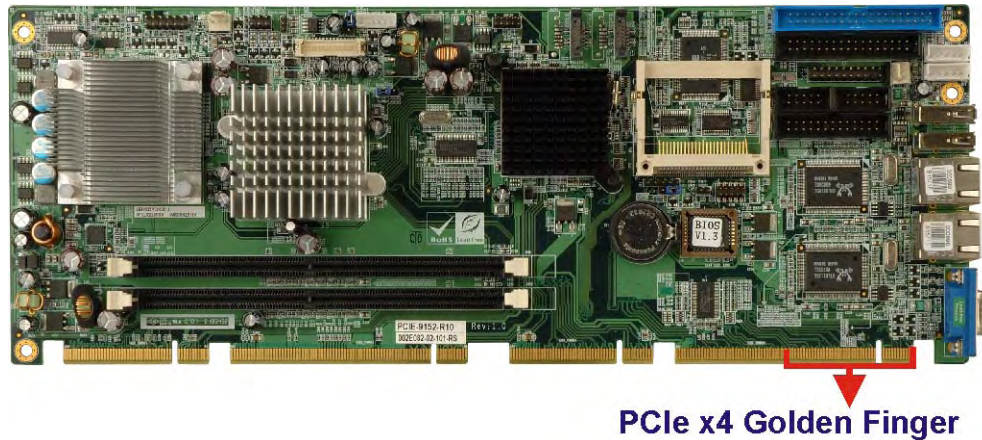

Figure 2-9: PCIe x4 Golden finger

2.7 LPC Bus Components

2.7.1 LPC Bus Overview

The LPC bus is connected to components listed below:

- BIOS chipset
- Super I/O chipset
- TPM connector

2.7.2 BIOS Chipset

The BIOS chipset has a licensed copy of AMI BIOS installed on the chipset. Some of the BIOS features are listed below:

- AMI Flash BIOS
- SMBIOS (DMI) compliant

3307740 PICMG 1.3 CPU Card

- Console redirection function support
- PXE (Pre-boot Execution Environment) support
- USB booting support

The BIOS chipset is shown in **Figure 2-10** below.

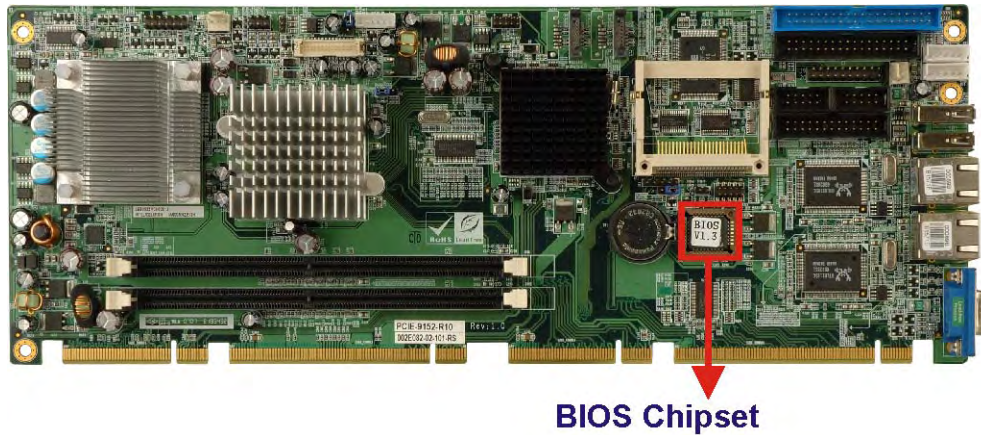

Figure 2-10: BIOS Chipset

2.7.3 Super I/O chipset

The iTE IT8712F Super I/O chipset is connected to the ICH7 southbridge through the LPC bus. The iTE IT8712F is an LPC interface-based Super I/O device that comes with Environment Controller integration.

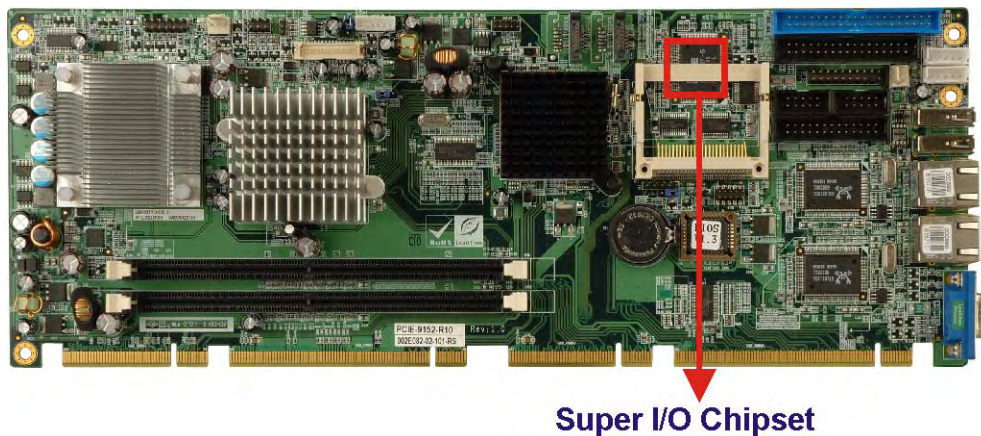

Figure 2-11: Super I/O Chipset

Some of the features of the iTE IT8712F chipset are listed below:

- LPC Interface
- PC98/99/2001, ACPI and LANDesk Compliant
- Enhanced Hardware Monitor
- Fan Speed Controller
- SmartGuardian Controller
- Single +5V Power Supply
- Two 16C550 UARTs for serial port control
- One IEEE 1284 Parallel Port
- Floppy Disk Controller
- Keyboard Controller
- Watchdog Timer
- Serial IRQ Support
- Vbat & Vcch Support
- Single +5V Power Supply

Some of the Super I/O features are described in more detail below:

2.7.3.1 Super I/O LPC Interface

The LPC interface on the Super I/O complies with the Intel® Low Pin Count Specification Rev. 1.0. The LPC interface supports both LDRQ# and SERIRQ protocols as well as PCI PME# interfaces.

2.7.3.2 Super I/O 16C550 UARTs

The onboard Super I/O has two integrated 16C550 UARTs that can support the following:

- Two standard serial ports (COM1 and COM2)
- IrDa 1.0 and ASKIR protocols

Another two chipsets connected to the LPC bus provided connectivity to another two serial port connectors (COM3 and COM4).

2.7.3.3 Super I/O Enhanced Hardware Monitor

The Super I/O Enhanced Hardware Monitor monitors three thermal inputs, VBAT internally, and eight voltage monitor inputs. These hardware parameters are reported in the BIOS and can be read from the BIOS Hardware Health Configuration menu.

2.7.3.4 Super I/O Fan Speed Controller

The Super I/O fan speed controller enables the system to monitor the speed of the fan. One of the pins on the fan connector is reserved for fan speed detection and interfaced to the fan speed controller on the Super I/O. The fan speed is then reported in the BIOS.

2.7.3.5 Super I/O Parallel Port

The Super I/O parallel port (LPT) supports standard mode, enhanced mode and high-speed mode parallel port devices. The LPT is compliant with the following LPT modes.

- Standard mode
 - Bi-directional SPP compliant
- Enhanced mode
 - EPP v1.7 compliant
 - EPP v1.9 compliant
- High-speed mode
 - ECP, IEEE 1284 compliant

2.7.3.6 Super I/O Keyboard Controller

The Super I/O keyboard controller can execute the 8042 instruction set. Some of the keyboard controller features are listed below:

- The 8042 instruction is compatible with a PS/2 keyboard and PS/2 mouse
- Gate A20 and Keyboard reset output
- Supports multiple keyboard power on events
- Supports mouse double-click and/or mouse move power on events

2.7.4 TPM Connector

The LPC bus is routed to a 20-pin TPM connector. The TPM connector facilitates the installation of a TPM. Three GLOBAL AMERICAN TPM are compatible with this connector and are listed below.

- **1007800**: 20-pin Sinosun TPM
- **1007810**: 20-pin Winbond TPM
- **1007790**: 20-pin Infineon TPM

For more details about the above listed GLOBAL AMERICAN TPM, please contact your Global American, Inc. sales representative.

2.8 Environmental and Power Specifications

2.8.1 System Monitoring

Three thermal inputs on the 3307740 Super I/O Enhanced Hardware Monitor monitor the following temperatures:

- System temperature
- Power temperature
- CPU temperature

Eight voltage inputs on the 3307740 Super I/O Enhanced Hardware Monitor monitor the following voltages:

- Vcore
- +2.5V
- +3.3V
- +5.0V
- +12.0V
- DDR Vtt
- +1.5V
- 5VSB

3307740 PICMG 1.3 CPU Card

The 3307740 Super I/O Enhanced Hardware Monitor also monitors the following voltages internally:

- VBAT

The 3307740 Super I/O Enhanced Hardware Monitor also monitors the following fan speeds:

- CPU Fan speed

The values for the above environmental parameters are all recorded in the BIOS Hardware Health Configuration menu.

2.8.2 Operating Temperature and Temperature Control

The maximum and minimum operating temperatures for the 3307740 are listed below.

- Minimum Operating Temperature: 0°C (32°F)
- Maximum Operating Temperature: 60°C (140°F)

A cooling fan and heat sink must be installed on the CPU. Thermal paste must be smeared on the lower side of the heat sink before it is mounted on the CPU. Heat sinks are also mounted on the northbridge and southbridge chipsets to ensure the operating temperature of these chips remain low.

2.8.3 Power Consumption

Table 2-3 shows the power consumption parameters for the 3307740 running with a 1.2GHz Intel® Pentium® M processor and with a 512MB PC4300 CL4 DDR2 DIMM.

| Voltage | Current |
|---------|---------|
| +3.3V | 3.64A |
| +5V | 1.98A |
| +12V | 1.75A |

Table 2-3: Power Consumption

2.9 Expansion Options

2.9.1 Expansion Options Overview

A number of compatible GLOBAL AMERICAN Inc. PICMG 1.3 backplanes and chassis can be used to develop and expanded system. These backplanes and chassis are listed below.

2.9.2 GLOBAL AMERICAN Expansion PICMG 1.3 Backplanes

The backplanes listed in **Table 2-4** are compatible with the 3307740 and can be used to develop highly integrated industrial applications. All of the backplanes listed below have 24-pin ATX connector and a 4-pin ATX connector. For more information about these backplanes please contact our sales team.

| Model | Total Slots | System | Expansion Slots | | | | System Type |
|---------|-------------|--------|-----------------|----|----|-----|-------------|
| | | | PCIe | | | PCI | |
| | | | x16 | x4 | x1 | | |
| 1107790 | 4 | One | 1 | 1 | - | 1 | Single |
| 1107780 | 4 | One | 1 | - | - | 2 | Single |
| 1107800 | 4 | One | 1 | - | 2 | - | Single |
| 1107810 | 5 | One | 1 | 1 | - | 2 | Single |
| 1107820 | 5 | One | 1 | - | 3 | - | Single |
| 1107740 | 6 | One | 1 | - | - | 3 | Single |
| 1107840 | 6 | One | 1 | 1 | - | 3 | Single |
| 1107770 | 6 | One | 1 | - | 3 | 1 | Single |
| 1107750 | 5 | One | 1 | - | 3 | - | Single |

3307740 PICMG 1.3 CPU Card

| Model | Total Slots | System | Expansion Slots | | | | System Type |
|---------|-------------|--------|-----------------|----|----|-----|-------------|
| | | | PCIe | | | PCI | |
| | | | x16 | x4 | x1 | | |
| 1107850 | 5 | One | 1 | - | 2 | 1 | Single |
| 1107860 | 7 | One | 1 | - | 2 | 3 | Single |
| 1107870 | 7 | One | 1 | - | 4 | 1 | Single |
| 1107880 | 8 | One | 1 | - | 3 | 3 | Single |
| 1107890 | 9 | One | 1 | - | 4 | 3 | Single |
| 1107900 | 10 | One | 1 | - | 4 | 4 | Single |
| 1107910 | 10 | One | 1 | - | 4 | 4 | Single |
| 1107920 | 13 | One | 1 | 1 | - | 2 | Dual |
| | | Two | 1 | - | 4 | 2 | |
| 1107930 | 13 | One | 1 | - | 3 | 8 | Single |
| 1107940 | 19 | One | 1 | - | 1 | 16 | Single |

Table 2-4: Compatible GLOBAL AMERICAN PICMG 1.3 Backplanes

2.9.3 GLOBAL AMERICAN Chassis

GLOBAL AMERICAN chassis available for 3307740 system development are listed in **Table 2-5**.

3307740 PICMG 1.3 CPU Card

For more information about these chassis please consult sales team.

| Model | Slot SBC | Mounting | Max Slots | Backplanes |
|---------|----------------|----------|-----------|--|
| 1407460 | Full-size | Wall | 4 | 1107790 1107780 1107800 |
| 1401422 | Full-size | Wall | 6 | 1107810 1107820 1107840 1107770 |
| 1404540 | Full-size | Wall | 6 | 1107810 1107820 1104840 1107770 |
| 1404580 | Full-size (4U) | Rack | 14 | 1107740 1107900 1107910 1107920 1107930 1107940 |
| 1404600 | Full-size (4U) | Rack | 14 | 1107740 1107900 1107910 1107920 1107930 |
| 1407670 | Full-size (4U) | Rack | 14 | 1107740 1107900 1107910 1107920 1107930 |
| 1404150 | Full-size (4U) | Rack | 14 | 1107740 1107900 |

3307740 PICMG 1.3 CPU Card

| Model | Slot SBC | Mounting | Max Slots | Backplanes |
|---------|----------------|----------|-----------|--|
| | | | | 1107910 1107920 1107930 1107940 |
| 1401032 | Full-size | Wall | 7 | 1107740 1107860 1107870 |
| 1401412 | Full-size | Wall | 10 | 1107740 1107880 |
| 1407660 | Full-size | Wall | 6 | 1107840 1107770 |
| 1404570 | Full-size (2U) | Rack | 6 | 1107750 1107850 |
| 1404552 | Full-size (2U) | Rack | 6 | 1107750 1107850 |

Table 2-5: Compatible GLOBAL AMERICAN Chassis

Chapter

3

Unpacking

3.1 Anti-static Precautions



WARNING:

Failure to take ESD precautions during the installation of the 3307740 may result in permanent damage to the 3307740 and severe injury to the user.

Electrostatic discharge (ESD) can cause serious damage to electronic components, including the 3307740. Dry climates are especially susceptible to ESD. It is therefore critical that whenever the 3307740, or any other electrical component is handled, the following anti-static precautions are strictly adhered to.

- **Wear an anti-static wristband:** - Wearing a simple anti-static wristband can help to prevent ESD from damaging the board.
- **Self-grounding:**- Before handling the board touch any grounded conducting material. During the time the board is handled, frequently touch any conducting materials that are connected to the ground.
- **Use an anti-static pad:** When configuring the 3307740, place it on an anti-static pad. This reduces the possibility of ESD damaging the 3307740.
- **Only handle the edges of the PCB:**- When handling the PCB, hold the PCB by the edges.

3.2 Unpacking

3.2.1 Unpacking Precautions

When the 3307740 is unpacked, please do the following:

- Follow the anti-static precautions outlined in Section 3.1.
- Make sure the packing box is facing upwards so the 3307740 does not fall out of the box.
- Make sure all the components shown in Section 3.3 are present.

3.3 Unpacking Checklist







Note:

If some of the components listed in the checklist below are missing, please do not proceed with the installation. Contact a Global American sales representative directly at salesinfo@globalamericaninc.com.

3.3.1 Package Contents

The 3307740 is shipped with the following components:

| Quantity | Item and Part Number | Image |
|----------|-----------------------|---|
| 1 | 3307740 |  |
| 1 | ATA 66/100 flat cable |  |
| 2 | SATA cable |  |
| 1 | SATA power cable |  |
| 1 | Dual RS-232 cable |  |

3307740 PICMG 1.3 CPU Card



| | | |
|---|--------------------------|---|
| 1 | Mini jumper pack |  |
| 1 | Quick installation guide |  |
| 1 | Utility CD | |

Table 3-1: Package List Contents

3.3.2 Optional Items





NOTE:







The items listed in this section are optional items that must be ordered separately. Please contact your 3307740 vendor, distributor or reseller for more information or, contact Global American directly or

[Tech Support](#)

The following optional items are available for the 3307740.

| Quantity | Item and Part Number | Image |
|----------|--|---|
| 1 | Audio kit_ 5.1 Channel (P/N: 1007750) |  |
| 1 | Audio kit_ 7.1 Channel (P/N: 1007760) |  |
| | | |

3307740 PICMG 1.3 CPU Card

| Quantity | Item and Part Number | Image |
|----------|--|---|
| 1 | VGA output SDVO card (P/N: 3907690) |  |
| 1 | DVI output SDVO card (P/N: 3907680) |  |
| 1 | 5-pin Wafer to PS/2 cable (P/N:1208370) |  |
| 1 | LPT cable (P/N:1207760) |  |
| 1 | FDD cable (P/N:1207764) |  |
| | | |
| | | |
| | | |
| | | |
| 1 | TPM (Sinosun) (P/N:1007800) |  |
| 1 | TPM (Winbond) (P/N:1007810) |  |

3307740 PICMG 1.3 CPU Card

| Quantity | Item and Part Number | Image |
|----------|---------------------------------|---|
| 1 | TPM (Infineon) (P/N:1007790) |  |

Table 3-2: Optional Items

Chapter

4

Connector Pinouts

4.1 Peripheral Interface Connectors

Section 4.1.2 shows peripheral interface connector locations. Section 4.1.2 lists all the peripheral interface connectors seen in Section 4.1.2.

4.1.1 3307740 Layout

Figure 4-1 shows the on-board peripheral connectors, rear panel peripheral connectors and on-board jumpers.

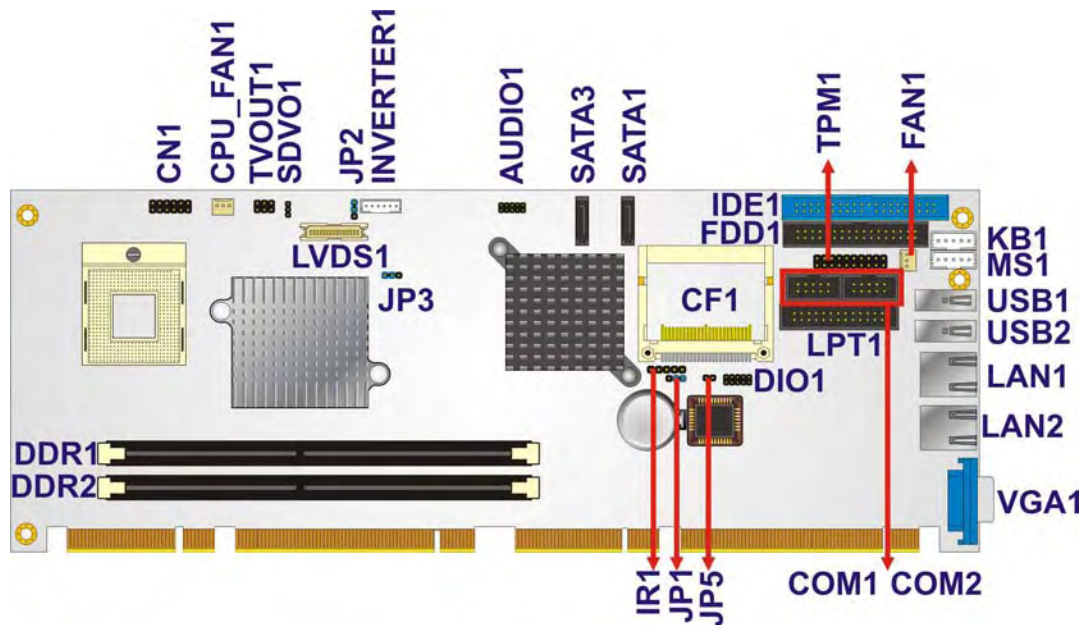

Figure 4-1: Connector and Jumper Locations

4.1.2 Peripheral Interface Connectors

Table 4-1 shows a list of the peripheral interface connectors on the 3307740. Detailed descriptions of these connectors can be found below.

| Connector | Type | Label |
|------------------------------|--------------------------|----------|
| Audio connector | 10-pin header | AUDIO1 |
| Compact Flash (CF) connector | 50-pin CF Type II socket | CF1 |
| Fan connector (CPU) | 3-pin wafer | CPU_FAN1 |

| Connector | Type | Label |
|-------------------------------|----------------------|-----------|
| Fan connector (system) | 3-pin wafer | SYS_FAN1 |
| Front panel connector | 12-pin header | CN1 |
| Floppy disk connector | 34-pin box header | FDD1 |
| GPIO connector | 10-pin header | DIO1 |
| IDE Interface connector | 40-pin box header | IDE1 |
| Infrared connector | 5-pin header | IR1 |
| Inverter power connector | 5-pin header | INVERTER1 |
| Keyboard connector | 5-pin wafer | KB1 |
| LVDS connector | 30-pin crimp | LVDS1 |
| Mouse connector | 5-pin wafer | MS1 |
| Parallel port connector | 26-pin header | LPT1 |
| SDVO connector | 3-pin header | SDVO1 |
| Serial ATA (SATA) connector | 7-pin SATA connector | SATA1 |
| Serial ATA (SATA) connector | 7-pin SATA connector | SATA3 |
| Serial port connector (COM 1) | 10-pin header | COM1 |
| Serial port connector (COM 2) | 10-pin header | COM2 |
| TPM connector | 20-pin header | TPM1 |
| TV out connector | 6-pin header | TVOUT1 |

Table 4-1: Peripheral Interface Connectors

4.1.3 External Interface Panel Connectors

Table 4-2 lists the rear panel connectors on the 3307740. Detailed descriptions of these connectors can be found in **Section 4.3 on page 87**

| Connector | Type | Label |
|--------------------|--------------|-------|
| Ethernet connector | RJ-45 | LAN1 |
| Ethernet connector | RJ-45 | LAN2 |
| USB port | USB port | USB1 |
| USB port | USB port | USB2 |
| VGA port connector | Female DB-15 | VGA1 |

Table 4-2: Rear Panel Connectors

4.2 Internal Peripheral Connectors

Internal peripheral connectors are found on the motherboard and are only accessible when the motherboard is outside of the chassis. This section has complete descriptions of all the internal, peripheral connectors on the 3307740.

4.2.1 Audio Connector (10-pin)

- CN Label:** AUDIO1
- CN Type:** 10-pin header
- CN Location:** See Figure 4-2
- CN Pinouts:** See Table 4-3

An optional module can be connected to the 10-pin audio connector to provide the system with a high quality AC'97 or Azalia compatible codec that provides a complete integrated audio solution.

3307740 PICMG 1.3 CPU Card

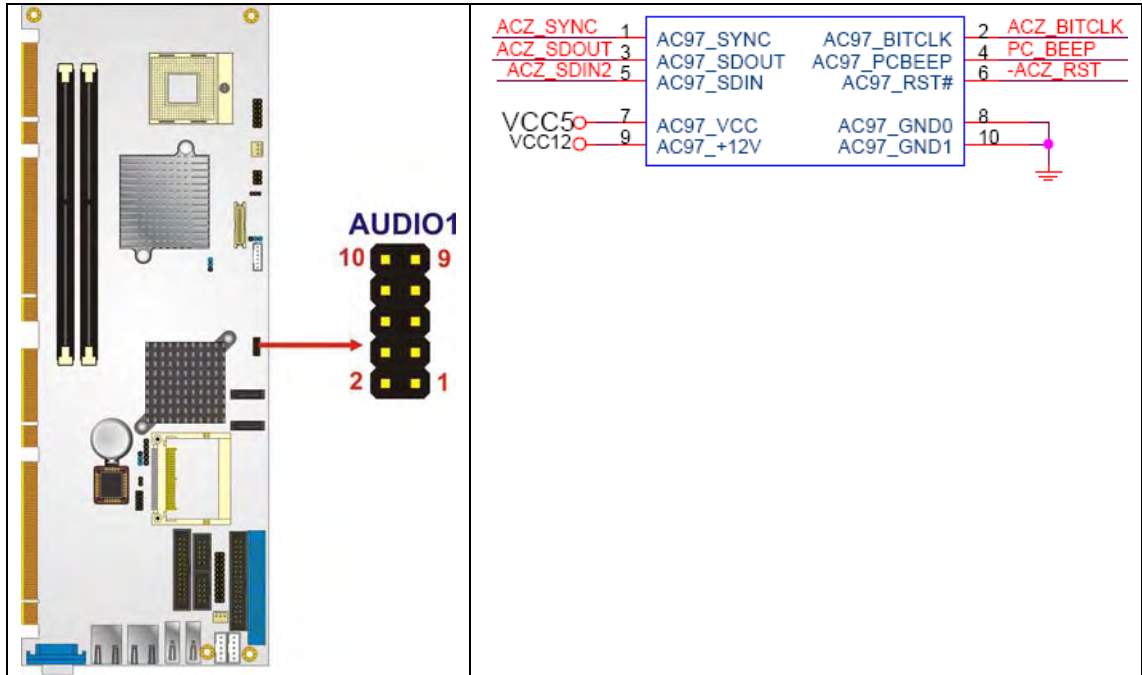

Figure 4-2: Audio Connector Pinouts (10-pin)

| PIN NO. | DESCRIPTION | PIN NO. | DESCRIPTION |
|---------|-------------|---------|-------------|
| 1 | AC97_SYNC | 2 | AC97_BITCLK |
| 3 | AC97_SDOUT | 4 | AC97_PCBEEP |
| 5 | AC97_SDIN | 6 | AC97_RST# |
| 7 | AC97_VCC | 8 | AC97_GND |
| 9 | AC97_12V | 10 | AC97_GND |

Table 4-3: Audio Connector Pinouts (10-pin)

3307740 PICMG 1.3 CPU Card

4.2.2 Backlight Inverter Connector

| | |
|---------------------|-----------------------|
| CN Label: | INVERTER1 |
| CN Type: | 6-pin wafer (1x6) |
| CN Location: | See Figure 4-3 |
| CN Pinouts: | See Table 4-4 |

The backlight inverter connector provides the backlight on the LCD display connected to the 3307740 with +12V of power.

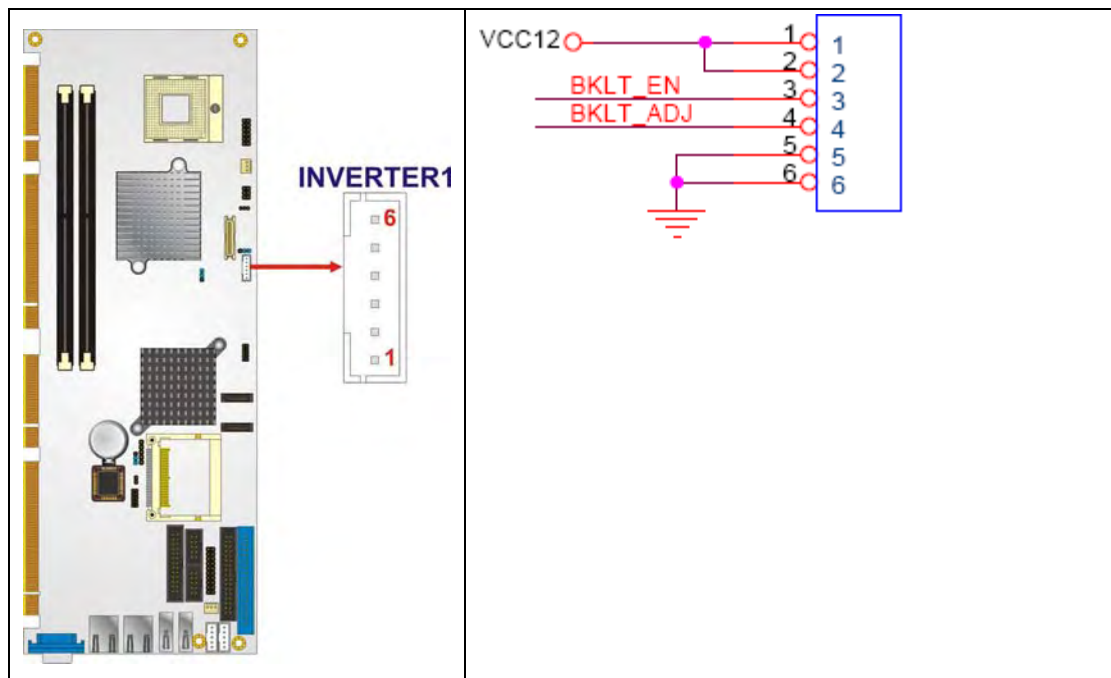

Figure 4-3: Panel Backlight Connector Pinout Locations

| PIN NO. | DESCRIPTION |
|---------|------------------|
| 1 | + 12V |
| 2 | + 12V |
| 3 | BACKLIGHT ENABLE |
| 4 | BACKLIGHT ADJUST |
| 5 | GROUND |
| 6 | GROUND |

Table 4-4: Panel Backlight Connector Pinouts

4.2.3 Compact Flash Socket

- CN Label:** CF1 (solder side)
- CN Type:** 50-pin header (2x25)
- CN Location:** See Figure 4-4
- CN Pinouts:** See Table 4-5

A CF Type I or Type II memory card is inserted to the CF socket on the solder side of the 3307740.

3307740 PICMG 1.3 CPU Card

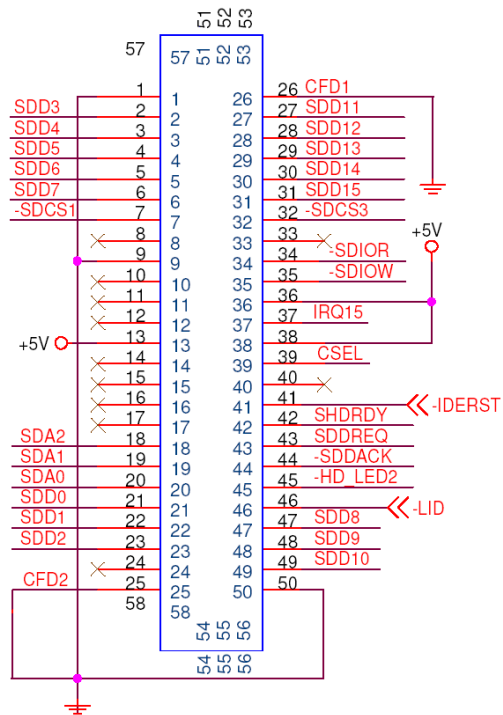
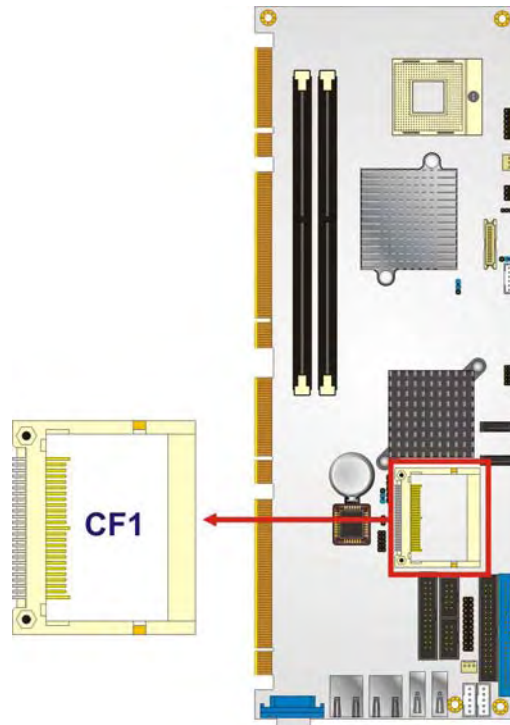

Figure 4-4: CF Card Socket Location

| PIN NO. | DESCRIPTION | PIN NO. | DESCRIPTION |
|---------|---------------|---------|---------------|
| 1 | GROUND | 26 | VCC-IN CHECK1 |
| 2 | DATA 3 | 27 | DATA 11 |
| 3 | DATA 4 | 28 | DATA 12 |
| 4 | DATA 5 | 29 | DATA 13 |
| 5 | DATA 6 | 30 | DATA 14 |
| 6 | DATA 7 | 31 | DATA 15 |
| 7 | HDC_CS0# | 32 | HDC_CS1 |
| 8 | N/C | 33 | N/C |
| 9 | GROUND | 34 | IOR# |
| 10 | N/C | 35 | IOW# |
| 11 | N/C | 36 | VCC_COM |
| 12 | N/C | 37 | IRQ15 |
| 13 | VCC_COM | 38 | VCC_COM |
| 14 | N/C | 39 | CSEL |
| 15 | N/C | 40 | N/C |
| 16 | N/C | 41 | HDD_RESET |
| 17 | N/C | 42 | IORDY |
| 18 | SA2 | 43 | SDREQ |
| 19 | SA1 | 44 | SDACK# |
| 20 | SA0 | 45 | HDD_ACTIVE# |
| 21 | DATA 0 | 46 | 66DET |
| 22 | DATA 1 | 47 | DATA 8 |
| 23 | DATA 2 | 48 | DATA 9 |
| 24 | N/C | 49 | DATA 10 |
| 25 | VCC-IN CHECK2 | 50 | GROUND |

Table 4-5: CF Card Socket Pinouts

4.2.4 Fan Connector (+12V)

CN Label: CPU_FAN1, SYS_FAN1

CN Type: 3-pin header

CN Location: See Figure 4-5

CN Pinouts: See Table 4-6

Two cooling fan connectors provide a 12V, 500mA current to a system cooling fan and a CPU cooling fan. The connector has a "rotation" pin to get rotation signals from fans and notify the system so the system BIOS can recognize the fan speed. Please note that only specified fans can issue the rotation signals.

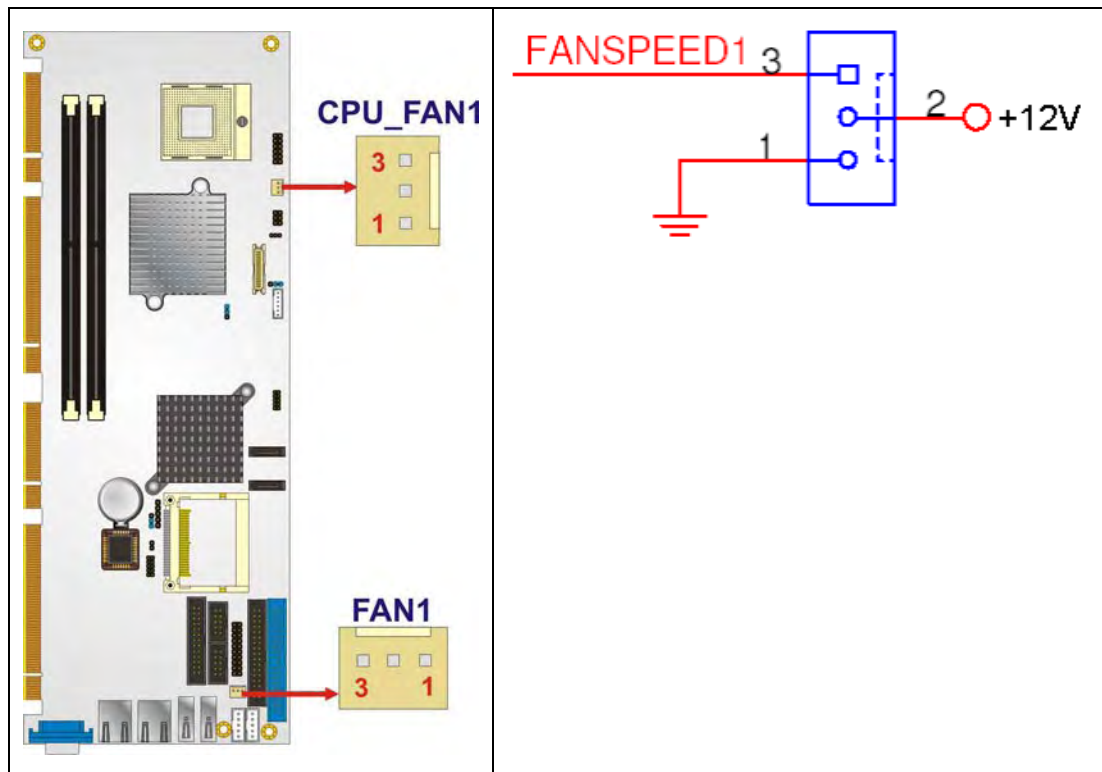

Figure 4-5: +12V Fan Connector Location

| PIN NO. | DESCRIPTION |
|---------|--------------|
| 1 | GND |
| 2 | +12V |
| 3 | Speed Detect |

Table 4-6: +12V Fan Connector Pinouts

4.2.5 Floppy Disk Connector (34-pin)

- CN Label:** FDD1
- CN Type:** 34-pin box header (2x17)
- CN Location:** See Figure 4-6
- CN Pinouts:** See Table 4-7

The floppy disk connector is connected to a floppy disk drive.

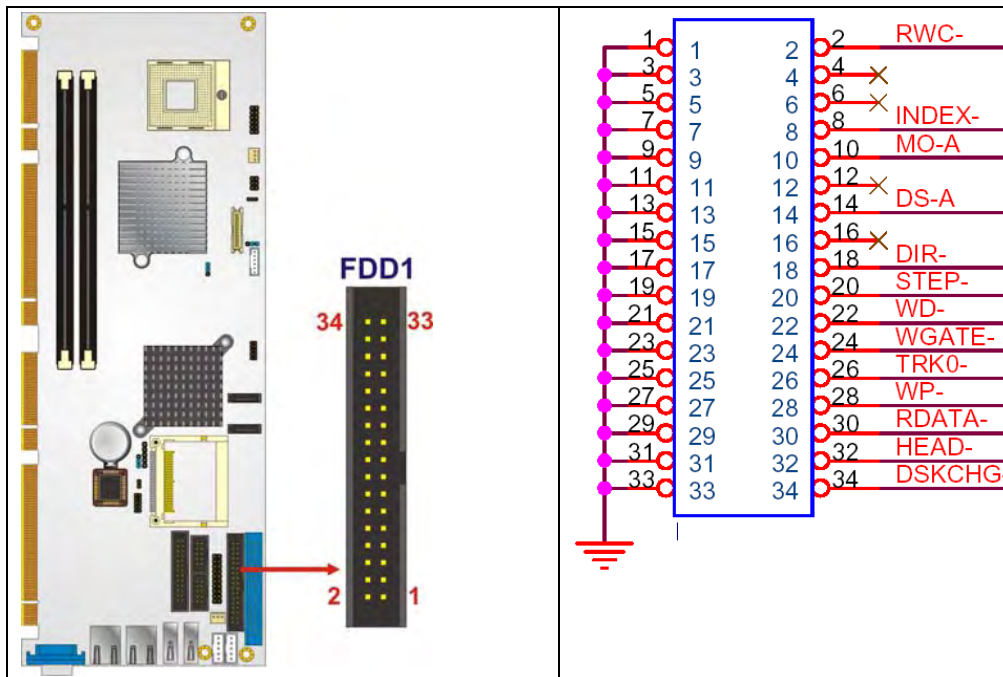

Figure 4-6: 34-pin FDD Connector Location

| PIN NO. | DESCRIPTION | PIN NO. | DESCRIPTION |
|---------|-------------|---------|-----------------|
| 1 | GND | 2 | REDUCE WRITE |
| 3 | GND | 4 | N/C |
| 5 | N/C | 6 | N/C |
| 7 | GND | 8 | INDEX# |
| 9 | GND | 10 | MOTOR ENABLE A# |
| 11 | GND | 12 | DRIVE SELECT B# |
| 13 | GND | 14 | DRIVE SELECT A# |
| 15 | GND | 16 | MOTOR ENABLE B# |
| 17 | GND | 18 | DIRECTION# |
| 19 | GND | 20 | STEP# |
| 21 | GND | 22 | WRITE DATA# |
| 23 | GND | 24 | WRITE GATE# |
| 25 | GND | 26 | TRACK 0# |
| 27 | GND | 28 | WRITE PROTECT# |
| 29 | GND | 30 | READ DATA# |
| 31 | GND | 32 | SIDE 1 SELECT# |
| 33 | GND | 34 | DISK CHANGE# |

Table 4-7: 34-pin FDD Connector Pinouts

4.2.6 GPIO Connector

- CN Label:** DIO1
- CN Type:** 10-pin header (2x5)
- CN Location:** See **Figure 4-7**
- CN Pinouts:** See **Table 4-8**

The GPIO connector can be connected to external I/O control devices including sensors, lights, alarms and switches.

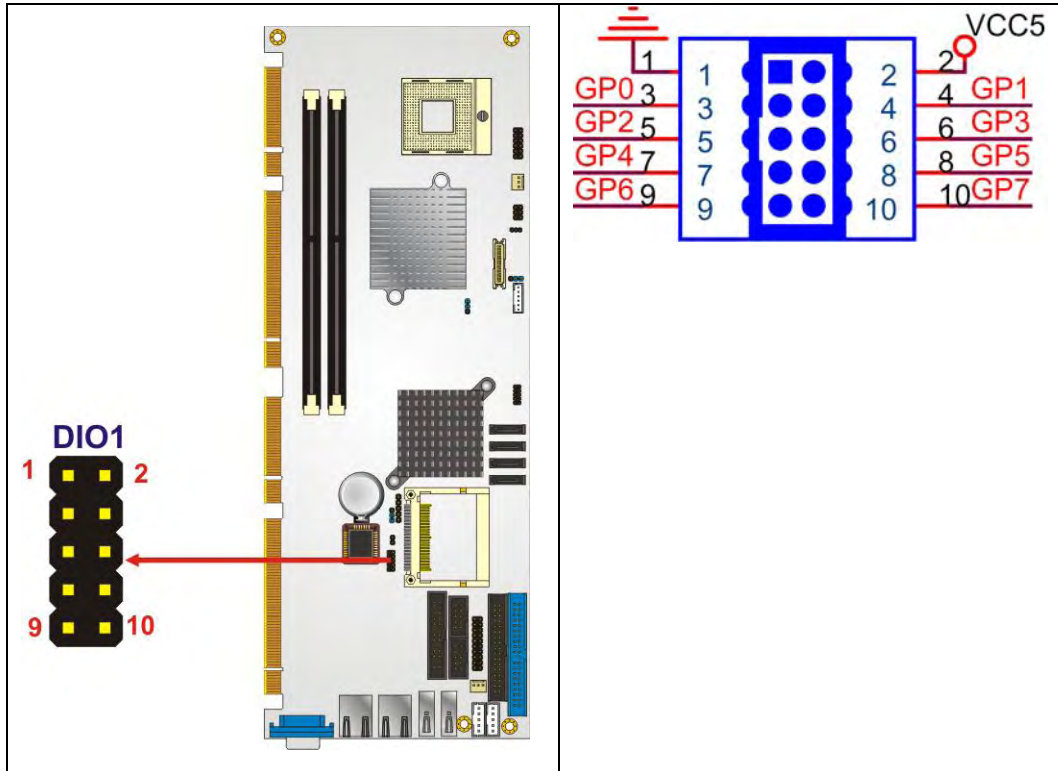

Figure 4-7: GPIO Connector Pinout Locations

| PIN NO. | DESCRIPTION | PIN NO. | DESCRIPTION |
|---------|-------------|---------|-------------|
| 1 | GND | 2 | +5V |
| 3 | GP0 | 4 | GP1 |
| 5 | GP2 | 6 | GP3 |
| 7 | GP4 | 8 | GP5 |
| 9 | GP6 | 10 | GP7 |

Table 4-8: GPIO Connector Pinouts

4.2.7 Front Panel Connector (12-pin)

- CN Label:** CN1
- CN Type:** 12-pin header (2x6)
- CN Location:** See Figure 4-8

3307740 PICMG 1.3 CPU Card

CN Pinouts: See Table 4-9

The front panel connector connects to external switches and indicators to monitor and controls the motherboard. These indicators and switches include:

- Power button
- Reset button
- Power LED
- HDD LED

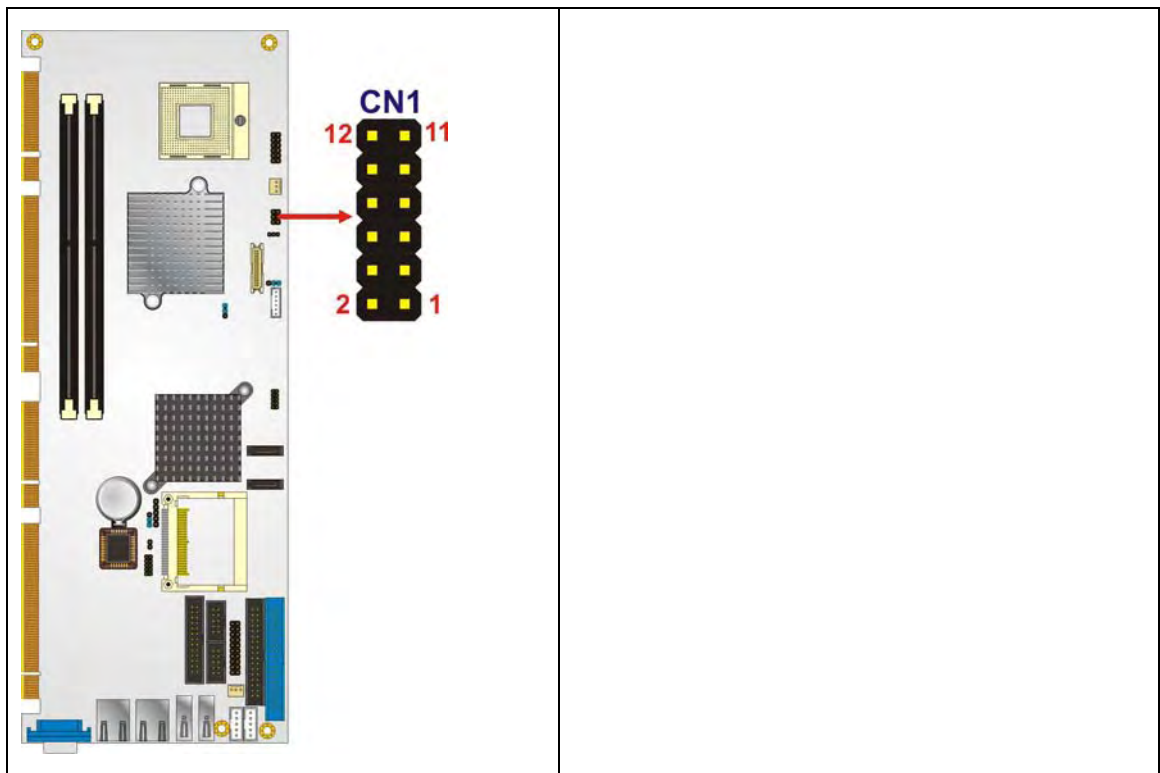

Figure 4-8: Front Panel Connector Pinout Locations

| FUNCTION | PIN | DESCRIPTION | FUNCTION | PIN | DESCRIPTION |
|--------------|-----|-------------|----------|-----|-------------|
| Power LED | 1 | LED+ | Buzzer | 2 | BUZZER- |
| | 3 | LED- | | 4 | NC |
| Power Button | 5 | BUTTON1 | | 6 | NC |
| | 7 | BUTTON2 | | 8 | VCC |

| | | | | | |
|---------|----|----------|-------|----|-------|
| HDD LED | 9 | HDD LED+ | Reset | 10 | RESET |
| | 11 | HDD LED- | | 12 | GND |

Table 4-9: Front Panel Connector Pinouts

4.2.8 IDE Connector(40-pin)

- CN Label:** IDE1
- CN Type:** 40-pin box header (2x20)
- CN Location:** See Figure 4-9
- CN Pinouts:** See Table 4-10

One 40-pin IDE device connector on the 3307740 supports connectivity to two hard disk drives.

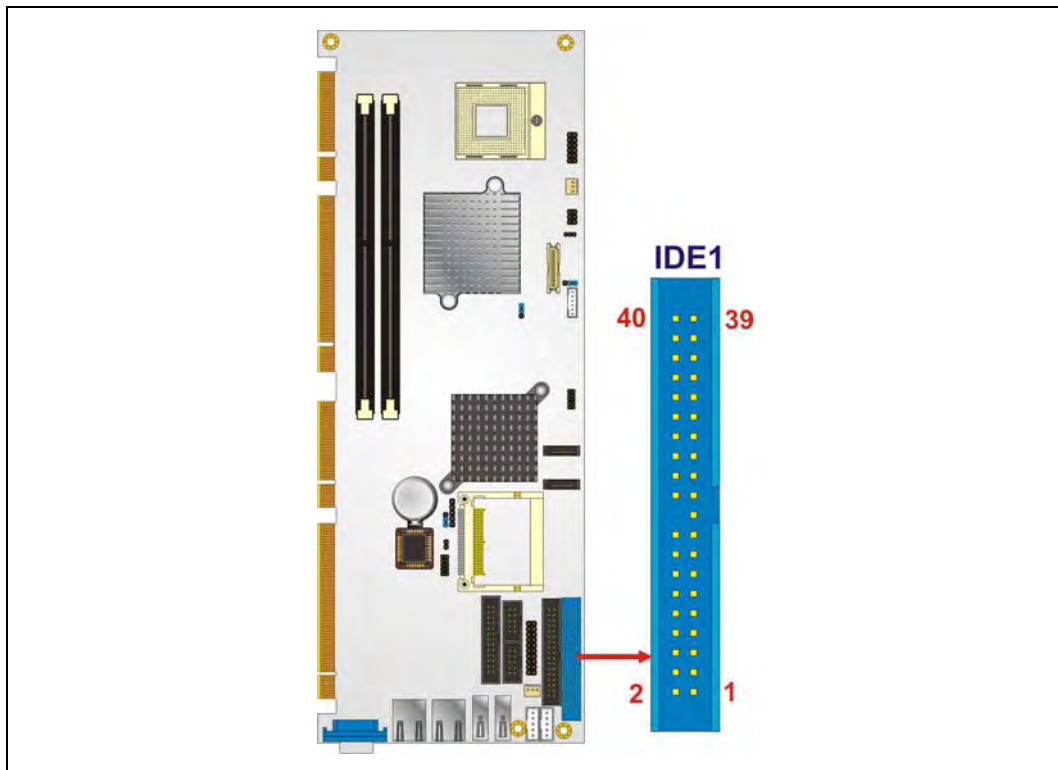

3307740 PICMG 1.3 CPU Card

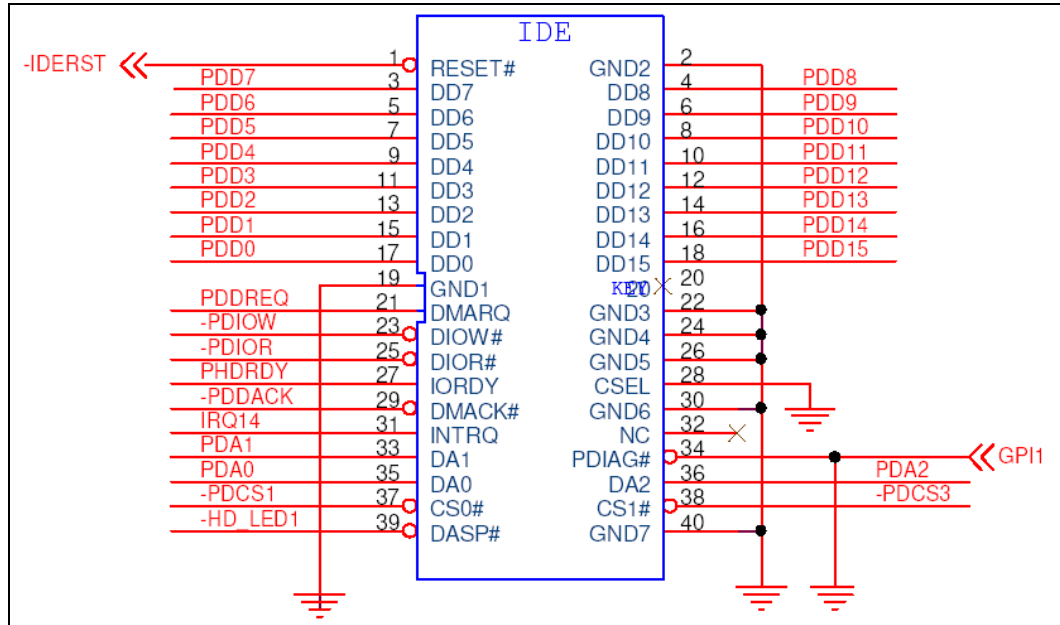

Figure 4-9: Secondary IDE Device Connector Locations

| PIN NO. | DESCRIPTION | PIN NO. | DESCRIPTION |
|---------|-------------|---------|----------------|
| 1 | RESET# | 2 | GROUND |
| 3 | DATA 7 | 4 | DATA 8 |
| 5 | DATA 6 | 6 | DATA 9 |
| 7 | DATA 5 | 8 | DATA 10 |
| 9 | DATA 4 | 10 | DATA 11 |
| 11 | DATA 3 | 12 | DATA 12 |
| 13 | DATA 2 | 14 | DATA 13 |
| 15 | DATA 1 | 16 | DATA 14 |
| 17 | DATA 0 | 18 | DATA 15 |
| 19 | GROUND | 20 | N/C |
| 21 | IDE DRQ | 22 | GROUND |
| 23 | IOW# | 24 | GROUND |
| 25 | IOR# | 26 | GROUND |
| 27 | IDE CHRDY | 28 | GROUND |
| 29 | IDE DACK | 30 | GROUND-DEFAULT |
| 31 | INTERRUPT | 32 | N/C |
| 33 | SA1 | 34 | N/C |

| | | | |
|----|-------------|----|----------|
| 35 | SA0 | 36 | SA2 |
| 37 | HDC CS0# | 38 | HDC CS1# |
| 39 | HDD ACTIVE# | 40 | GROUND |

Table 4-10: Secondary IDE Connector Pinouts

4.2.9 Infrared Interface Connector (5-pin)

- CN Label:** IR1
- CN Type:** 5-pin header (1x5)
- CN Location:** See Figure 4-10
- CN Pinouts:** See Table 4-11

The infrared interface connector supports both Serial Infrared (SIR) and Amplitude Shift Key Infrared (ASKIR) interfaces.

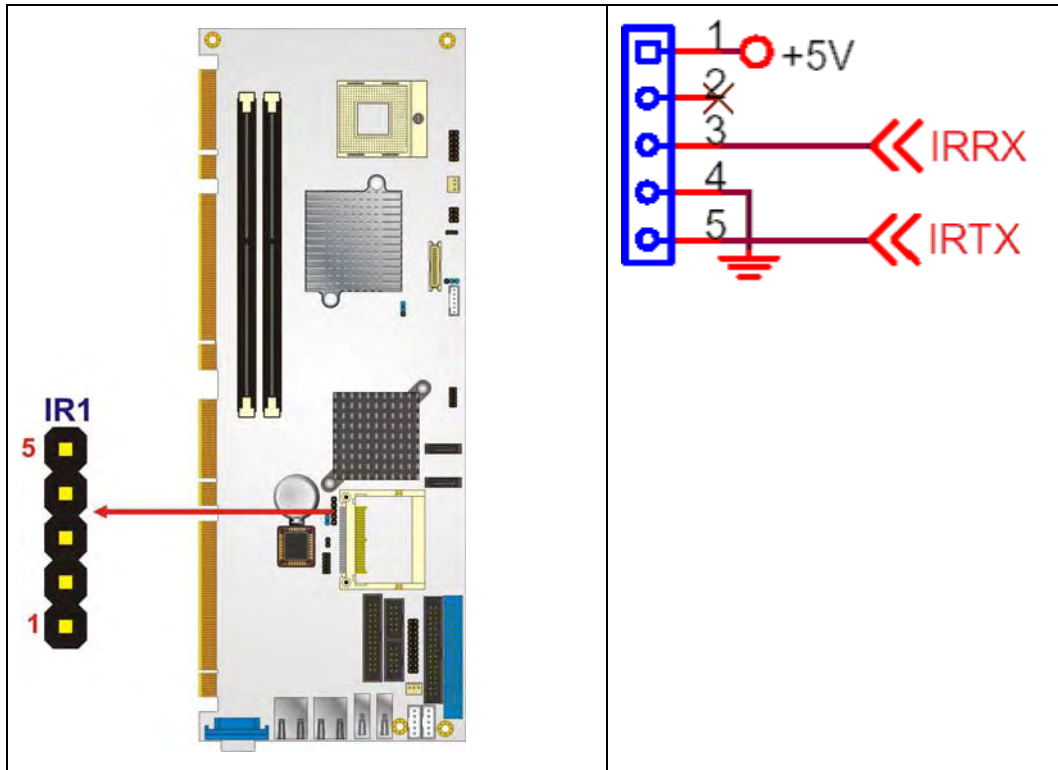

Figure 4-10: Infrared Connector Pinout Locations

3307740 PICMG 1.3 CPU Card

| PIN NO. | DESCRIPTION |
|---------|-------------|
| 1 | VCC |
| 2 | NC |
| 3 | IR-RX |
| 4 | GND |
| 5 | IR-TX |

Table 4-11: Infrared Connector Pinouts

4.2.10 Keyboard Connector

- CN Label:** KB1
- CN Type:** 5-pin header (1x5)
- CN Location:** See Figure 4-11
- CN Pinouts:** See Table 4-12

The keyboard connector can be connected to a standard PS/2 cable to add keyboard functionality to the system.

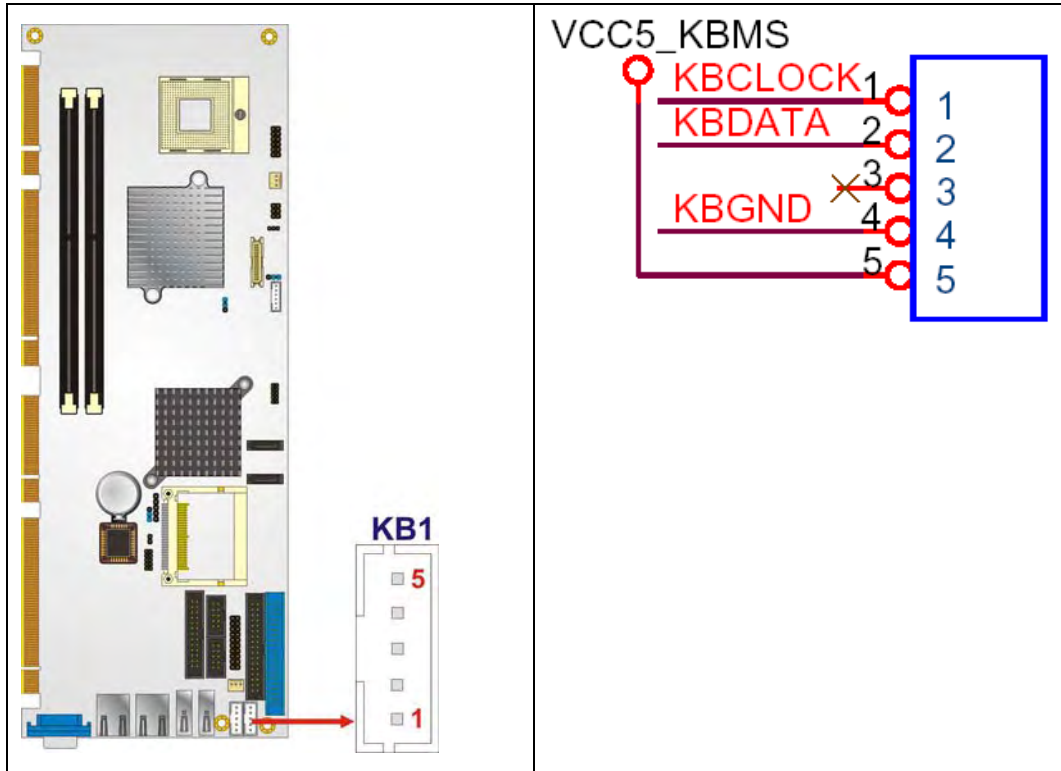

Figure 4-11: Keyboard Connector Location

| PIN NO. | DESCRIPTION |
|---------|----------------|
| 1 | KEYBOARD CLOCK |
| 2 | KEYBOARD DATA |
| 3 | N/C |
| 4 | GROUND |
| 5 | VCC |

Table 4-12: Keyboard Connector Pinouts

4.2.11 LVDS LCD Connector

- CN Label:** LVDS1
- CN Type:** 30-pin crimp (2x10)
- CN Location:** See Figure 4-12
- CN Pinouts:** See Table 4-13

3307740 PICMG 1.3 CPU Card

The 30-pin LVDS LCD connector can be connected to single channel or dual channel, 18-bit LVDS panel.

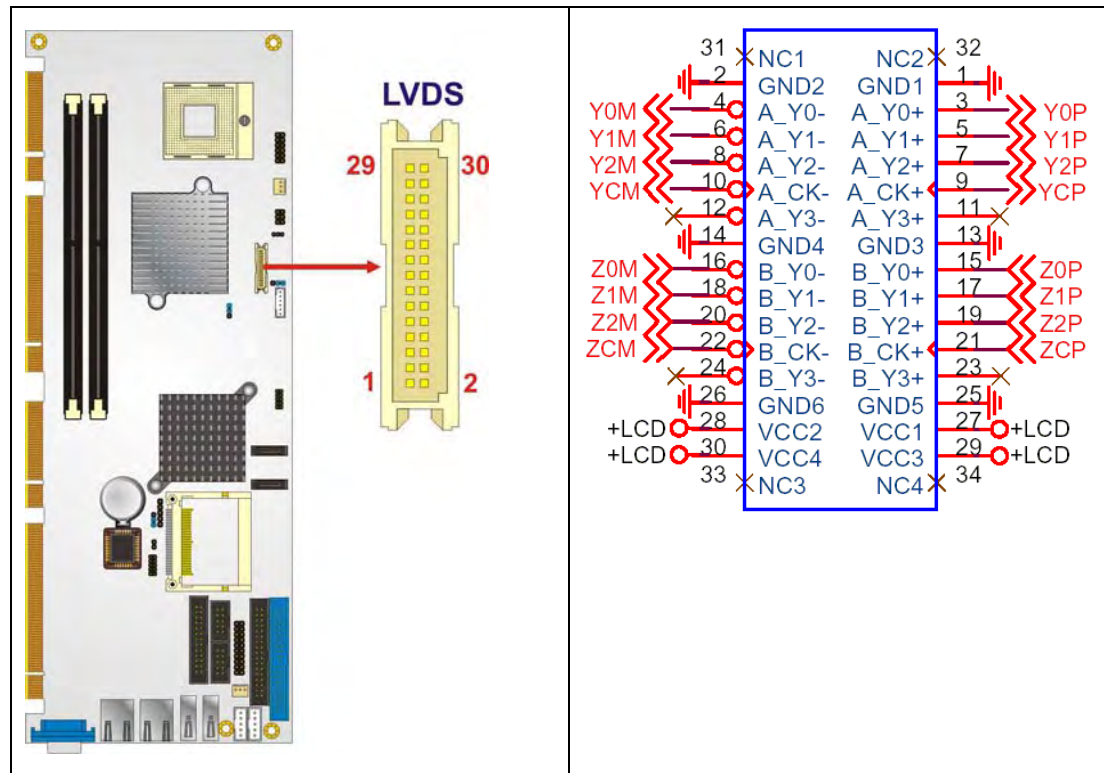

Figure 4-12: LVDS LCD Connector Pinout Locations

| PIN NO. | DESCRIPTION | PIN NO. | DESCRIPTION |
|---------|-------------|---------|-------------|
| 1 | GROUND | 2 | GROUND |
| 3 | LVDSA_Y0+ | 4 | LVDSA_Y0- |
| 5 | LVDSA_Y1+ | 6 | LVDSA_Y1- |
| 7 | LVDSA_Y2+ | 8 | LVDSA_Y2- |
| 9 | LVDSA_CLK+ | 10 | LVDSA_CLK- |
| 11 | NC | 12 | NC |
| 13 | GROUND | 14 | GROUND |
| 15 | LVDSB_Y0+ | 16 | LVDSB_Y0- |
| 17 | LVDSB_Y1+ | 18 | LVDSB_Y1- |
| 19 | LVDSB_Y2+ | 20 | LVDSB_Y2- |
| 21 | LVDSB_CLK+ | 22 | LVDSB_CLK- |

| | | | |
|----|----------|----|----------|
| 23 | NC | 24 | NC |
| 25 | GROUND | 26 | GROUND |
| 27 | VCC_LVDS | 28 | VCC_LVDS |
| 29 | VCC_LVDS | 30 | VCC_LVDS |

Table 4-13: LVDS LCD Port Connector Pinouts

4.2.12 Mouse Connector

- CN Label:** MS1
- CN Type:** 5-pin header (1x5)
- CN Location:** See Figure 4-11
- CN Pinouts:** See Table 4-12

The mouse connector can be connected to a standard PS/2 cable to add keyboard and mouse functionality to the system.

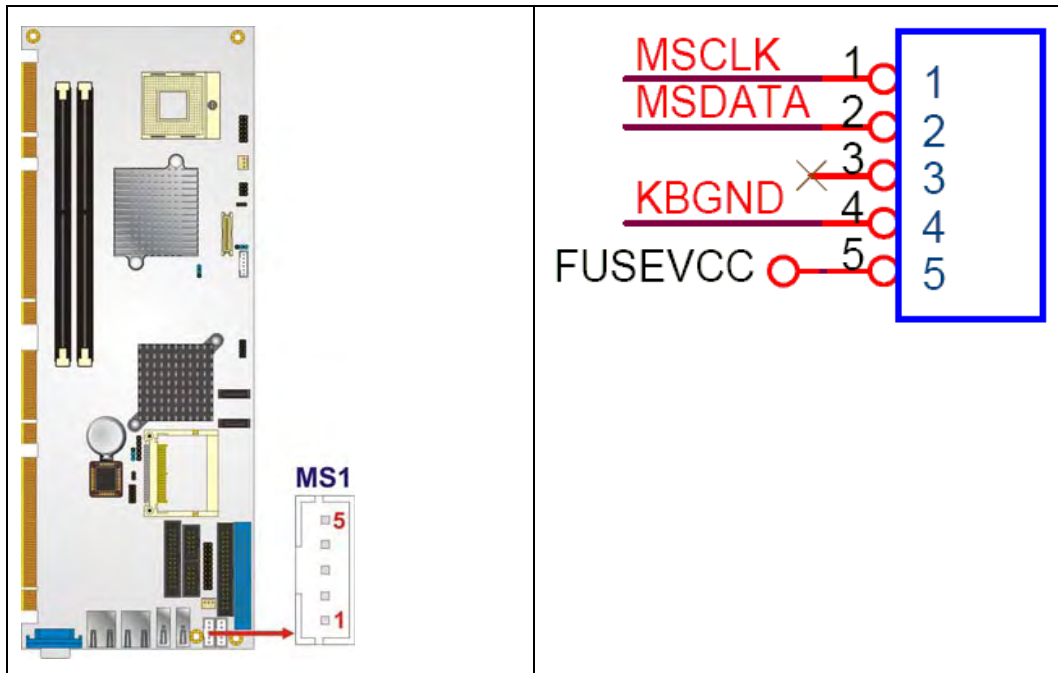

Figure 4-13: Mouse Connector Location

| PIN NO. | DESCRIPTION |
|---------|-------------|
| 1 | MOUSE CLOCK |
| 2 | MOUSE DATA |
| 3 | N/C |
| 4 | GROUND |
| 5 | VCC |

Table 4-14: Mouse Connector Pinouts

4.2.13 Parallel Port Connector

- CN Label:** LPT1
- CN Type:** 26-pin box header
- CN Location:** See Figure 4-14
- CN Pinouts:** See Table 4-15

The 26-pin parallel port connector connects to a parallel port connector interface or some other parallel port device such as a printer.

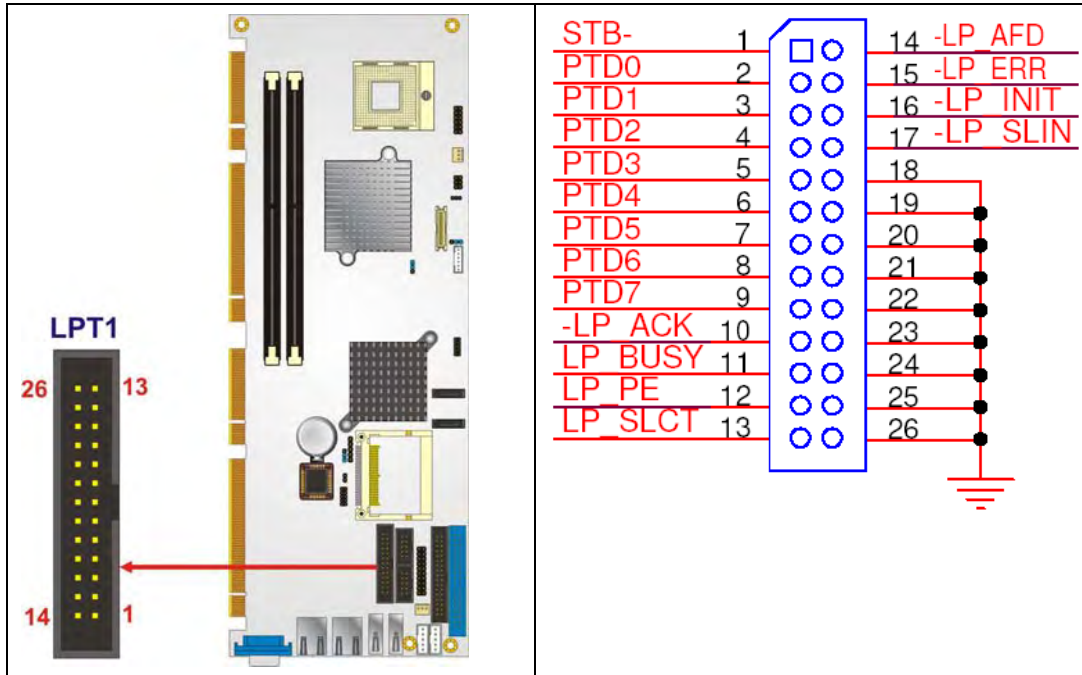

Figure 4-14: Parallel Port Connector Location

| PIN NO. | DESCRIPTION | PIN NO. | DESCRIPTION |
|---------|--------------------|---------|------------------|
| 1 | STROBE# | 2 | DATA 0 |
| 3 | DATA 1 | 4 | DATA 2 |
| 5 | DATA 3 | 6 | DATA 4 |
| 7 | DATA 5 | 8 | DATA 6 |
| 9 | DATA 7 | 10 | ACKNOWLEDGE |
| 11 | BUSY | 12 | PAPER EMPTY |
| 13 | PRINTER SELECT | 14 | AUTO FORM FEED # |
| 15 | ERROR# | 16 | INITIALIZE |
| 17 | PRINTER SELECT LN# | 18 | GROUND |
| 19 | GROUND | 20 | GROUND |
| 21 | GROUND | 22 | GROUND |
| 23 | GROUND | 24 | GROUND |
| 25 | GROUND | 26 | NC |

Table 4-15: Parallel Port Connector Pinouts

4.2.14 SATA Drive Connectors

- CN Label:** SATA1 and SATA3
- CN Type:** 7-pin SATA drive connectors
- CN Location:** See Figure 4-15
- CN Pinouts:** See Table 4-16

The two SATA drive connectors are each connected to a SATA drive. SATA drives transfer data at speeds as high as 150Mb/s.

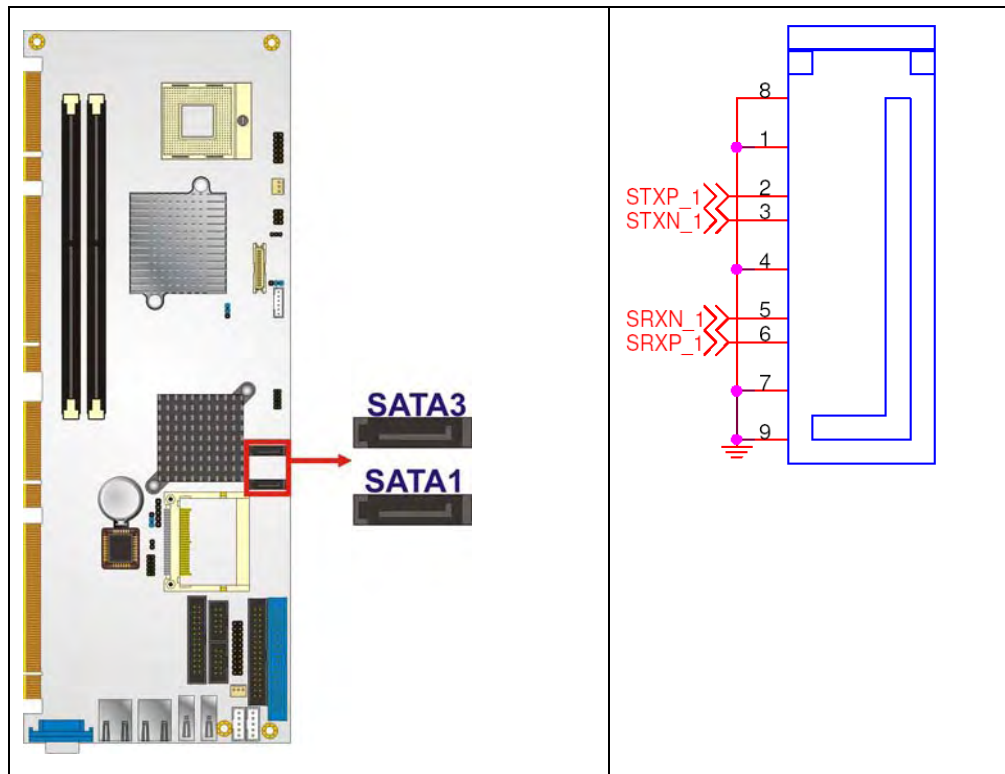

Figure 4-15: SATA Drive Connector Locations

| PIN NO. | DESCRIPTION |
|---------|-------------|
| 1 | GND |
| 2 | TX+ |
| 3 | TX- |

| PIN NO. | DESCRIPTION |
|---------|-------------|
| 4 | GND |
| 5 | RX- |
| 6 | RX+ |
| 7 | GND |

Table 4-16: SATA Drive Connector Pinouts

4.2.15 SDVO Connector

- CN Label:** SDVO1
- CN Type:** 3-pin header (1x3)
- CN Location:** See Figure 4-16
- CN Pinouts:** See Table 4-17

The SDVO connector is connected to and SDVO graphics card installed on the backplane.

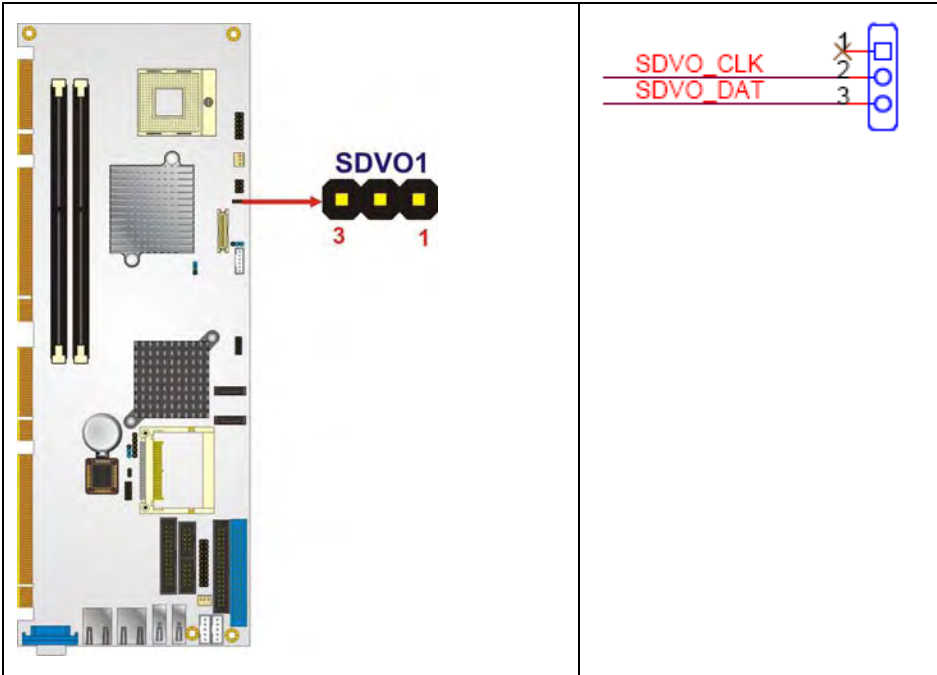

Figure 4-16: SDVO Connector Pinout Locations

3307740 PICMG 1.3 CPU Card

| PIN NO. | DESCRIPTION |
|---------|-------------|
| 1 | NC |
| 2 | SDVO CLK |
| 3 | SDVO DATA |

Table 4-17: SDVO Pinouts

4.2.16 Serial Port Connector (COM1 and COM2)

- CN Label:** COM1 and COM2
- CN Type:** 10-pin header (2x5)
- CN Location:** See Figure 4-17
- CN Pinouts:** See Table 4-18

The 10-pin serial port connector provides a second RS-232 serial communications channel. The serial port connectors can be connected to external RS-232 serial port devices.

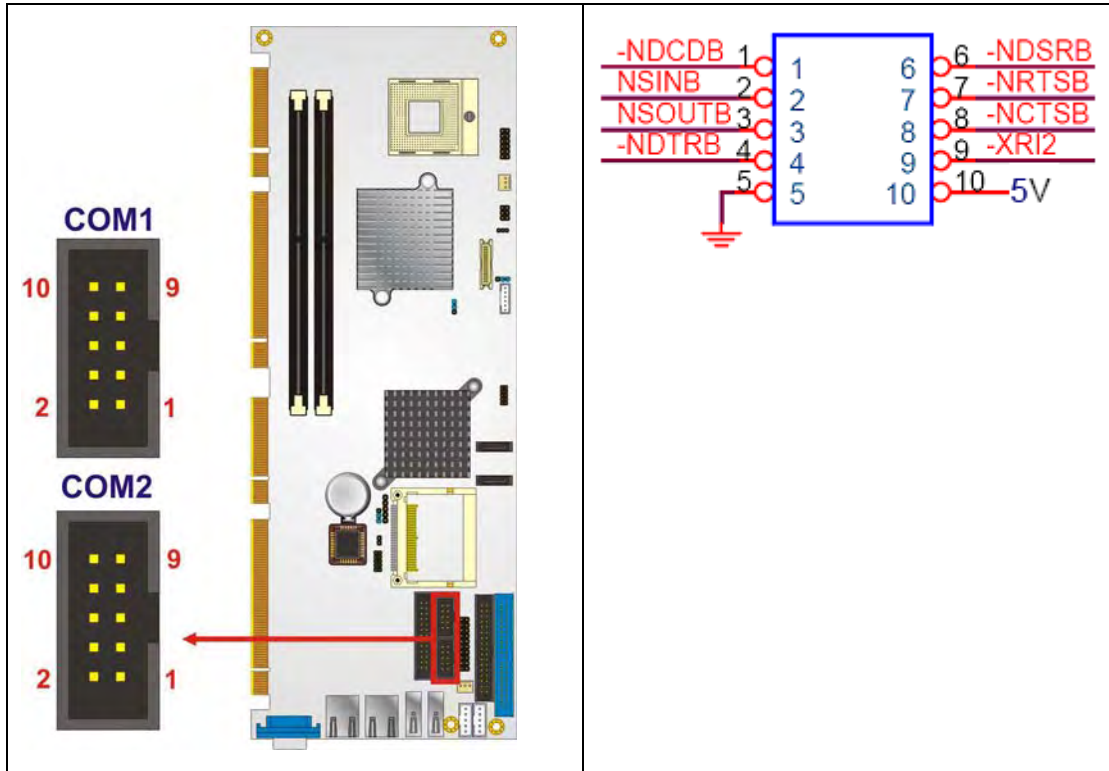

Figure 4-17: COM1 and COM2 Connector Pinout Locations

| PIN NO. | DESCRIPTION | PIN NO. | DESCRIPTION |
|---------|---------------------------|---------|-------------------------|
| 1 | Data Carrier Detect (DCD) | 6 | Data Set to Ready (DSR) |
| 2 | Receive Data (RXD) | 7 | Request to Send (RTS) |
| 3 | Transmit Data (TXD) | 8 | Clear to Sent (CTS) |
| 4 | Data Terminal Ready (DTR) | 9 | Ring Indicator (RI) |
| 5 | Ground (GND) | 10 | 5V |

Table 4-18: COM1 and COM2

4.2.17 Trusted Platform Module (TPM) Connector

- CN Label: TPM1
- CN Type: 20-pin header (2x10)
- CN Location: See Figure 4-19

3307740 PICMG 1.3 CPU Card

CN Pinouts: See Table 4-20

The Trusted Platform Module (TPM) connector secures the system on bootup.

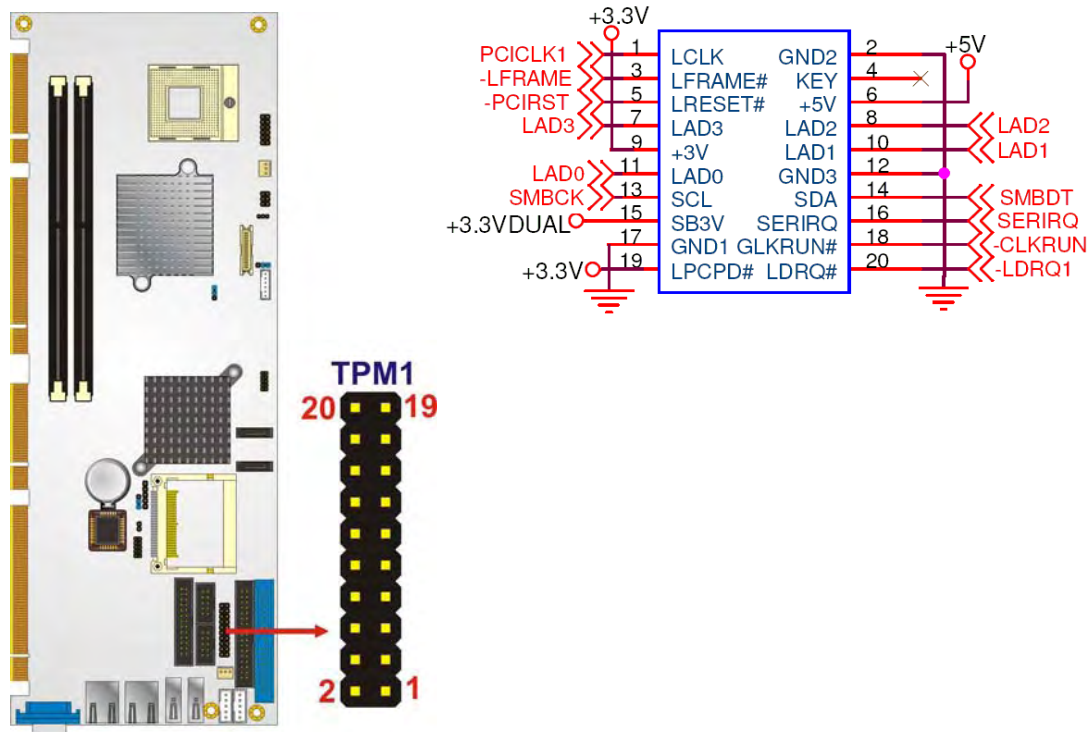

Figure 4-18: TPM Connector Pinout Locations

| PIN NO. | DESCRIPTION | PIN NO. | DESCRIPTION |
|---------|-------------|---------|-------------|
| 1 | LCLK | 2 | GND2 |
| 3 | LFRAME# | 4 | KEY |
| 5 | LRESET# | 6 | +5V |
| 7 | LAD3 | 8 | LAD2 |
| 9 | +3V | 10 | LAD1 |
| 11 | LAD0 | 12 | GND3 |
| 13 | SCL | 14 | SDA |
| 15 | SB3V | 16 | SERIRQ |
| 17 | GND1 | 18 | GLKRUN# |

| | | | |
|----|--------|----|-------|
| 19 | LPCPD# | 20 | LDRQ# |
|----|--------|----|-------|

Table 4-19: TPM Connector Pinouts

4.2.18 TV Out Connector

- CN Label:** TVOUT1
- CN Type:** 6-pin header (2x3)
- CN Location:** See Figure 4-19
- CN Pinouts:** See Table 4-20

The 2x3 pin TV out connector connects to a TV output by using an S-Video or RCA connector. The TV out connector makes displaying media data on a television easier. HDTV resolutions up to 1080i / 1080P by component interface are also supported.

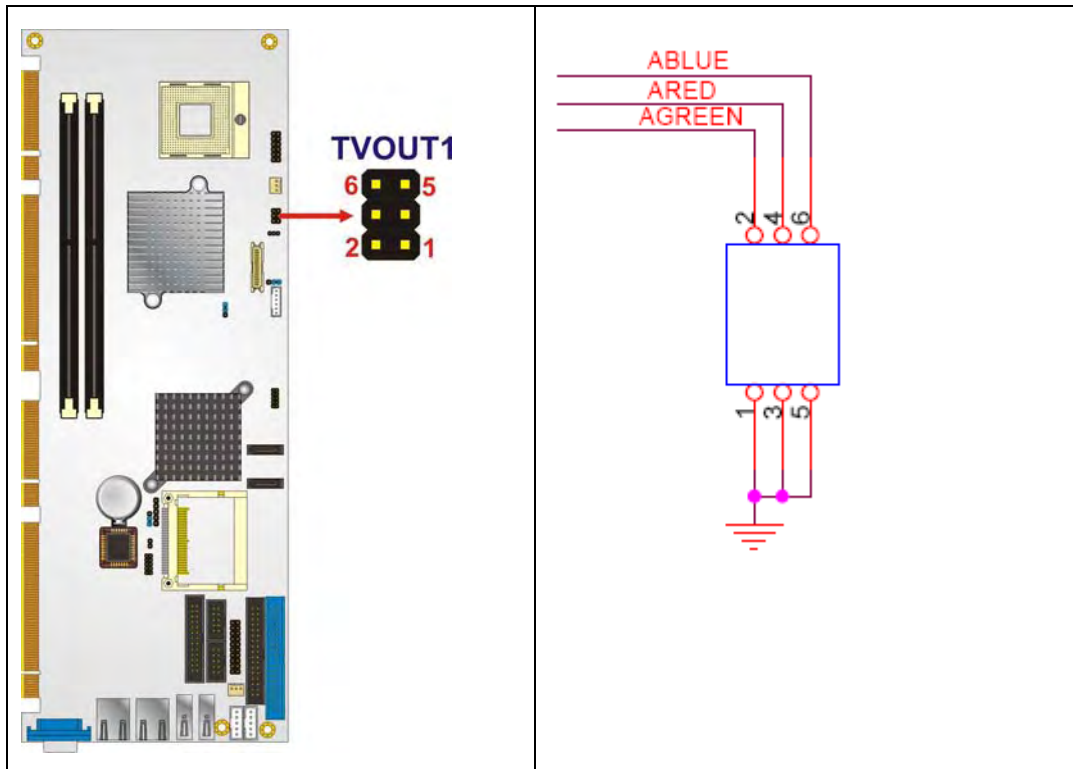

Figure 4-19: TV Connector Pinout Locations

| PIN NO. | DESCRIPTION | PIN NO. | DESCRIPTION |
|---------|-------------|---------|-------------|
| 1 | GND | 2 | GREEN |
| 3 | GND | 4 | RED |
| 5 | GND | 6 | BLUE |

Table 4-20: TV OutConnector Pinouts

4.3 External Peripheral Interface Connector Panel

Figure 4-20 shows the 3307740 rear panel. The 3307740 rear panel consists of two RJ-45 Ethernet connectors, a PS/2 keyboard connector a USB port and a VGA connector. These connectors are accessible when the 3307740 is installed in a chassis.



Figure 4-20: 3307740 External Peripheral Interface Connector

4.3.1 LAN Connectors

| | |
|---------------------|-----------------|
| CN Label: | LAN1 and LAN2 |
| CN Type: | RJ-45 |
| CN Location: | See Figure 4-20 |
| CN Pinouts: | See Table 4-21 |

The 3307740 is equipped with two built-in GbE Ethernet controllers. The controllers can connect to the LAN through two RJ-45 LAN connectors. There are two LEDs on the connector indicating the status of LAN. The pin assignments are listed in the following table:

| PIN | DESCRIPTION | PIN | DESCRIPTION |
|-----|-------------|-----|-------------|
| 1 | TXA+ | 5 | TXC- |
| 2 | TXA- | 9 | TXB- |
| 3 | TXB+ | 10 | TXD+ |
| 4 | TXC+ | 11 | TXD- |

Table 4-21: LAN Pinouts

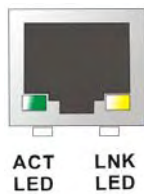

Figure 4-21: RJ-45 Ethernet Connector

The RJ-45 Ethernet connector has two status LEDs, one green and one yellow. The green LED indicates activity on the port and the yellow LED indicates the port is linked. See Table 4-22.

| STATUS | DESCRIPTION | STATUS | DESCRIPTION |
|--------|-------------|--------|-------------|
| GREEN | Activity | YELLOW | Linked |

Table 4-22: RJ-45 Ethernet Connector LEDs

4.3.2 USB Connector

CN Label: USB1 and USB2

CN Type: USB port

CN Location: See Figure 4-20

CN Pinouts: See Table 4-23

3307740 PICMG 1.3 CPU Card

The 3307740 has a one external USB 2.0 port. The port connects to both USB 2.0 and USB 1.1 devices.

| PIN NO. | DESCRIPTION |
|---------|-------------|
| 1 | VCC |
| 2 | DATA- |
| 3 | DATA+ |
| 4 | GND |

Table 4-23: USB Port Pinouts

4.3.3 VGA Connector

CN Label: VGA1

CN Type: 15-pin Female

CN Location: See Figure 4-20

CN Pinouts: See Figure 4-22 and Table 4-24

The 3307740 has a single 15-pin female connector for connectivity to standard display devices.

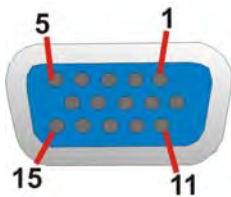

Figure 4-22: VGA Connector

| PIN | DESCRIPTION | PIN | DESCRIPTION |
|-----|-------------|-----|-------------|
| 1 | RED | 2 | GREEN |
| 3 | BLUE | 4 | NC |

| PIN | DESCRIPTION | PIN | DESCRIPTION |
|-----|-------------|-----|-------------|
| 5 | GND | 6 | GND |
| 7 | GND | 8 | GND |
| 9 | VCC / NC | 10 | GND |
| 11 | NC | 12 | DDC DAT |
| 13 | HSYNC | 14 | VSYNC |
| 15 | DDCCLK | | |

Table 4-24: VGA Connector Pinouts

THIS PAGE IS INTENTIONALLY LEFT BLANK

Chapter

5

Installation

5.1 Anti-static Precautions



WARNING:

Failure to take ESD precautions during the installation of the 3307740 may result in permanent damage to the 3307740 and severe injury to the user.

Electrostatic discharge (ESD) can cause serious damage to electronic components, including the 3307740. Dry climates are especially susceptible to ESD. It is therefore critical that whenever the 3307740, or any other electrical component is handled, the following anti-static precautions are strictly adhered to.

- **Wear an anti-static wristband:** - Wearing a simple anti-static wristband can help to prevent ESD from damaging the board.
- **Self-grounding:**- Before handling the board touch any grounded conducting material. During the time the board is handled, frequently touch any conducting materials that are connected to the ground.
- **Use an anti-static pad:** When configuring the 3307740, place it on an anti-static pad. This reduces the possibility of ESD damaging the 3307740.
- **Only handle the edges of the PCB:-:** When handling the PCB, hold the PCB by the edges.

5.2 Installation Considerations



NOTE:

The following installation notices and installation considerations should be read and understood before the 3307740 is installed. All installation notices pertaining to the installation of the 3307740 should be strictly adhered to. Failing to adhere to these precautions may lead to severe damage of the 3307740 and injury to the person installing the motherboard.

5.2.1 Installation Notices



WARNING:

The installation instructions described in this manual should be carefully followed in order to prevent damage to the 3307740, 3307740 components and injury to the user.

Before and during the installation please **DO** the following:

- Read the user manual:
 - The user manual provides a complete description of the 3307740 installation instructions and configuration options.
- Wear an electrostatic discharge cuff (ESD):
 - Electronic components are easily damaged by ESD. Wearing an ESD cuff removes ESD from the body and helps prevent ESD damage.
- Place the 3307740 on an antistatic pad:
 - When installing or configuring the motherboard, place it on an antistatic pad. This helps to prevent potential ESD damage.
- Turn all power to the 3307740 off:

3307740 PICMG 1.3 CPU Card

- When working with the 3307740, make sure that it is disconnected from all power supplies and that no electricity is being fed into the system.

Before and during the installation of the 3307740 **DO NOT**:

- Remove any of the stickers on the PCB board. These stickers are required for warranty validation.
- Use the product before verifying all the cables and power connectors are properly connected.
- Allow screws to come in contact with the PCB circuit, connector pins, or its components.

5.2.2 Installation Checklist

The following checklist is provided to ensure the 3307740 is properly installed.

- All the items in the packing list are present
- The CPU is installed
- The CPU cooling kit is properly installed
- A compatible memory module is properly inserted into the slot
- The CF Type I or CF Type II card is properly installed into the CF socket
- The jumpers have been properly configured
- The 3307740 is inserted into a chassis with adequate ventilation
- The correct power supply is being used
- The following devices are properly connected
 - IDE device
 - SATA drives
 - Keyboard and mouse cable
 - Audio kit
 - Power supply
 - USB cable
 - Serial port cable
 - Parallel port cable
- The following external peripheral devices are properly connected to the chassis:
 - VGA screen

- USB device
- LAN connection

5.3 CPU, CPU Cooling Kit and DIMM Installation



WARNING:

A CPU should never be turned on without the specified cooling kit being installed. If the cooling kit (heat sink and fan) is not properly installed and the system turned on, permanent damage to the CPU, 3307740 and other electronic components attached to the system may be incurred. Running a CPU without a cooling kit may also result in injury to the user.

The CPU, CPU cooling kit and DIMM are the most critical components of the 3307740. If one of these component is not installed the 3307740 cannot run.

5.3.1 Socket 479 CPU Installation

If this manual has been packaged with one of the following 3307740 models, please skip this section as the CPU is preinstalled.

- 3307740A
- 3307740B
- 3307740C

If a CPU is not preinstalled on the 3307740, please follow the installation instructions below.

3307740 PICMG 1.3 CPU Card



WARNING:

CPUs are expensive and sensitive components. When installing the CPU please be careful not to damage it in anyway. Make sure the CPU is installed properly and ensure the correct cooling kit is properly installed.

To install a socket 479 CPU onto the 3307740, follow the steps below:



WARNING:

When handling the CPU, only hold it on the sides. DO NOT touch the pins at the bottom of the CPU.

Step 1: Unlock the CPU retention screw. When shipped, the retention screw of the CPU socket should be in the unlocked position. If it is not in the unlocked position, use a screwdriver to unlock the screw. See **Figure 5-1**.

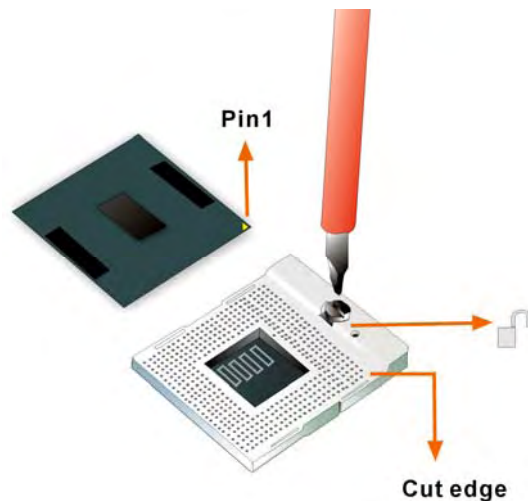

Figure 5-1: Make sure the CPU socket retention screw is unlocked

- Step 2: Inspect the CPU socket.** Make sure there are no bent pins and make sure the socket contacts are free of foreign material. If any debris is found, remove it with compressed air.
- Step 3: Correctly Orientate the CPU.** Make sure the IHS (integrated heat sink) side is facing upwards.
- Step 4: Correctly position the CPU.** Match the Pin 1 mark with the cut edge on the CPU socket. See **Figure 5-1**.
- Step 5: Align the CPU pins.** Carefully align the CPU pins with the holes in the CPU socket.
- Step 6: Insert the CPU.** Gently insert the CPU into the socket. If the CPU pins are properly aligned, the CPU should slide into the CPU socket smoothly.
- Step 7: Lock the retention screw.** Rotate the retention screw into the locked position. See **Figure 5-2**.

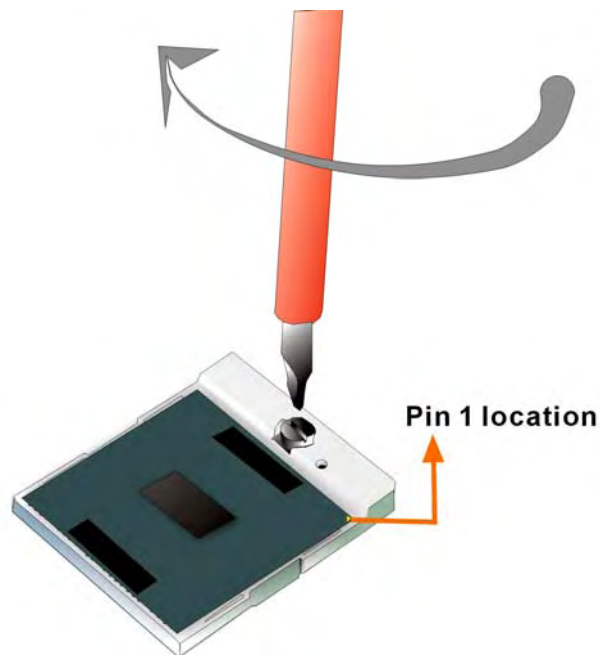

Figure 5-2: Lock the CPU Socket Retention Screw

5.3.2 DIMM Installation



WARNING:

Using incorrectly specified DIMM may cause permanently damage the 3307740. Please make sure the purchased DIMM complies with the memory specifications of the 3307740. DIMM specifications compliant with the 3307740 are listed in **Chapter 2**.

To install a DIMM into a DIMM socket, please follow the steps below and refer to **Figure 5-3**.

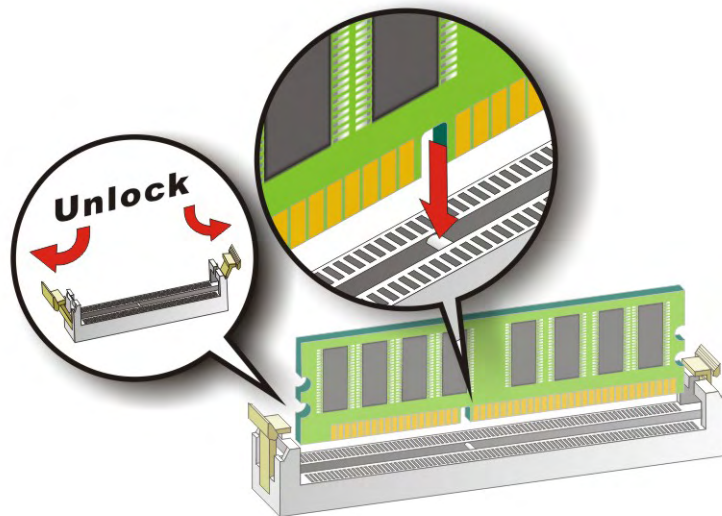

Figure 5-3: Installing a DIMM

- Step 1: Open the DIMM socket handles.** The DIMM socket has two handles that secure the DIMM into the socket. Before the DIMM can be inserted into the socket, the handles must be opened. See **Figure 5-3**.
- Step 2: Align the DIMM with the socket.** The DIMM must be oriented in such a way that the notch in the middle of the DIMM must be aligned with the plastic bridge

in the socket. See **Figure 5-3**.

Step 3: Insert the DIMM. Once properly aligned, the DIMM can be inserted into the socket. As the DIMM is inserted, the white handles on the side of the socket will close automatically and secure the DIMM to the socket. See **Figure 5-3**.

Step 4: Removing a DIMM. To remove a DIMM, push both handles outward. The memory module is ejected by a mechanism in the socket.

5.3.3 CF Card Installation



NOTE:

The 3307740 can support both CF Type I cards and CF Type II cards. For the complete specifications of the supported CF cards please refer to **Chapter 2**.

To install the a CF card (Type 1 or Type 2) onto the 3307740, please follow the steps below:

Step 1: Locate the CF card socket. Place the 3307740 on an anti-static pad with the solder side facing up. Locate the CF card.

Step 2: Align the CF card. Make sure the CF card is properly aligned with the CF socket.

Step 3: Insert the CF card. Gently insert the CF card into the socket making sure the socket pins are properly inserted into the socket. See **Figure 5-4**.

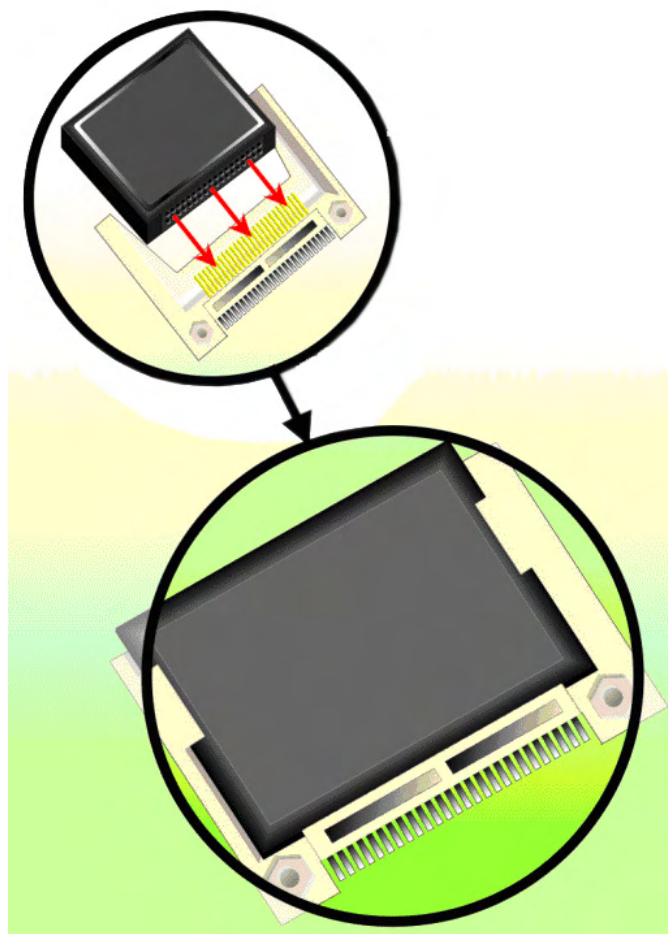

Figure 5-4: CF Card Installation

5.4 Jumper Settings



NOTE:

A jumper is a metal bridge used to close an electrical circuit. It consists of two or three metal pins and a small metal clip (often protected by a plastic cover) that slides over the pins to connect them. To CLOSE/SHORT a jumper means connecting the pins of the jumper with the plastic clip and to OPEN a jumper means removing the plastic clip from a jumper.

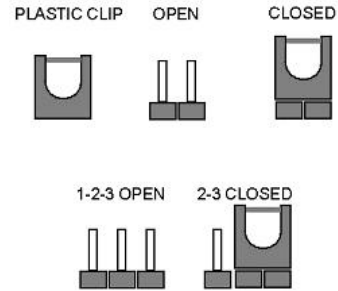

Figure 5-5: Jumper Locations

Before the 3307740 is installed in the system, the jumpers must be set in accordance with the desired configuration. The jumpers on the 3307740 are listed in **Table 5-1**.

| Description | Label | Type |
|------------------------|-------|--------------|
| CF card setup | JP5 | 2-pin header |
| Clear CMOS | JP1 | 3-pin header |
| FSB Selection | JP3 | 3-pin header |
| LVDS voltage selection | JP2 | 3-pin header |

Table 5-1: Jumpers

5.4.1 CF Card Setup

| | |
|-------------------------|----------------|
| Jumper Label: | JP5 |
| Jumper Type: | 2-pin header |
| Jumper Settings: | See Table 5-2 |
| Jumper Location: | See Figure 5-6 |

3307740 PICMG 1.3 CPU Card

The CF Card Setup jumper sets the CF Type I card or CF Type II cards as either the slave device or the master device. CF Card Setup jumper settings are shown in **Table 5-2**.

| AT Power Select | Description | |
|-----------------|-------------|---------|
| Open | Slave | Default |
| Close | Master | |

Table 5-2: CF Card Setup Jumper Settings

The CF Card Setup jumper location is shown in **Figure 5-6**.

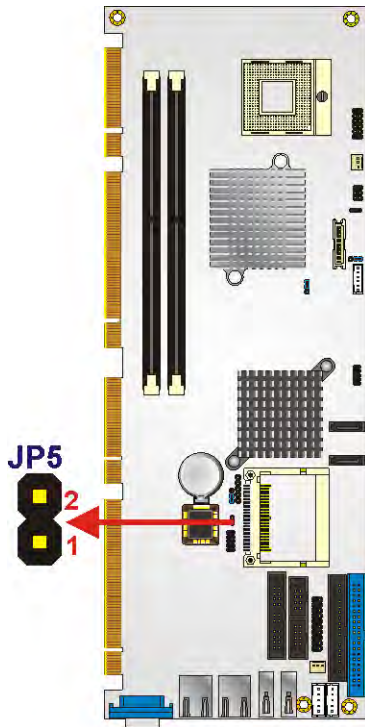

Figure 5-6: CF Card Setup Jumper Location

5.4.2 Clear CMOS Jumper

| | |
|-------------------------|---------------|
| Jumper Label: | JP1 |
| Jumper Type: | 3-pin header |
| Jumper Settings: | See Table 5-3 |

Jumper Location: See Figure 5-7

If the 3307740 fails to boot due to improper BIOS settings, the clear CMOS jumper clears the CMOS data and resets the system BIOS information. To do this, use the jumper cap to close pins 2 and 3 for a few seconds then reinstall the jumper clip back to pins 1 and 2.

If the “CMOS Settings Wrong” message is displayed during the boot up process, the fault may be corrected by pressing the F1 to enter the CMOS Setup menu. Do one of the following:

- Enter the correct CMOS setting
- Load Optimal Defaults
- Load Failsafe Defaults.

After having done one of the above, save the changes and exit the CMOS Setup menu.

The clear CMOS jumper settings are shown in **Table 5-3**.

| AT Power Select | Description | |
|-----------------|------------------|---------|
| Short 1 - 2 | Keep CMOS Setup | Default |
| Short 2 - 3 | Clear CMOS Setup | |

Table 5-3: Clear CMOS Jumper Settings

The location of the clear CMOS jumper is shown in **Figure 5-7** below.

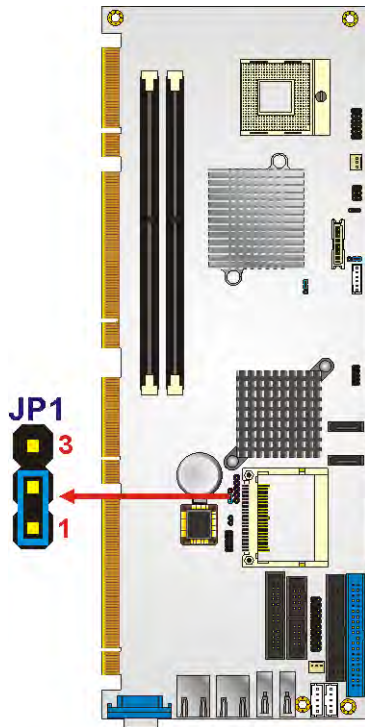

Figure 5-7: Clear CMOS Jumper

5.4.3 FSB Setup Jumper

| | |
|-------------------------|----------------|
| Jumper Label: | JP3 |
| Jumper Type: | 3-pin header |
| Jumper Settings: | See Table 5-4 |
| Jumper Location: | See Figure 5-8 |

The clear FSB setup jumper enables a user to select the FSB speed on the 3307740. The FSB Setup jumper settings are shown in **Table 5-3**.

| FSB Setup | Description | |
|-------------|-------------|---------|
| Short 1 – 2 | 100MHz | Default |
| Short 2 – 3 | 133MHz | |

Table 5-4: FSB Setup Jumper Settings

The location of the FSB Setup jumper is shown in **Figure 5-7** below.

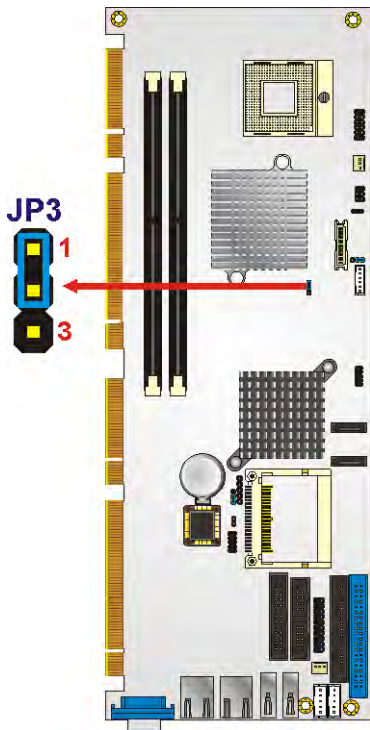

Figure 5-8: FSB Setup Jumper Jumper

5.4.4 LVDS Voltage Selection



WARNING:

Permanent damage to the screen and 3307740 may occur if the wrong voltage is selected with this jumper. Please refer to the user guide that came with the monitor to select the correct voltage.

3307740 PICMG 1.3 CPU Card

| | |
|-------------------------|----------------|
| Jumper Label: | JP2 |
| Jumper Type: | 3-pin header |
| Jumper Settings: | See Table 5-5 |
| Jumper Location: | See Figure 5-9 |

The **LVDS Voltage Selection** jumper allows the LVDS screen voltage to be set. The **LVDS Voltage Selection** jumper settings are shown in **Table 5-5**.

| AT Power Select | Description | |
|-----------------|-------------|---------|
| Short 1-2 | +3.3V LVDS | Default |
| Short 2-3 | +5V LVDS | |

Table 5-5: LVDS Voltage Selection Jumper Settings

The LVDS Voltage Selection jumper location, is shown in **Figure 5-9**.

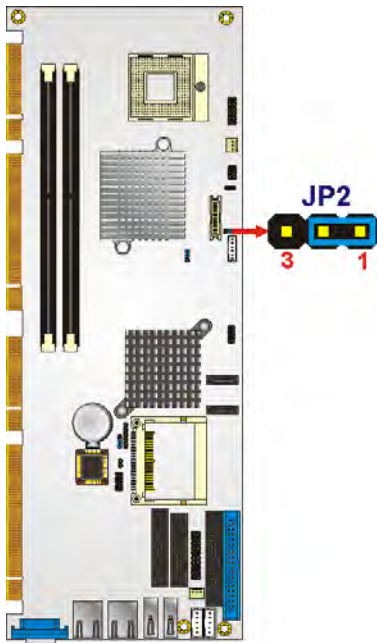

Figure 5-9: LVDS Voltage Selection Jumper Pinout Locations

5.5 Chassis Installation

5.5.1 Airflow



WARNING:

Airflow is critical to the cooling of the CPU and other onboard components. The chassis in which the 3307740 must have air vents to allow cool air to move into the system and hot air to move out.

The 3307740 must be installed in a chassis with ventilation holes on the sides allowing airflow to travel through the heat sink surface. In a system with an individual power supply unit, the cooling fan of a power supply can also help generate airflow through the board surface.



NOTE:

Global American has a wide range of backplanes available. Please contact your 3307740 vendor, reseller or an Global American sales representative, or visit the Global American website www.globalamericaninc.com to find out more about the available chassis.

5.5.2 Backplane Installation

Before the 3307740 can be installed into the chassis, a backplane must first be installed. Please refer to the installation instructions that came with the backplane and the chassis to see how to install the backplane into the chassis.



NOTE:

GLOBAL AMERICAN has a wide range of backplanes available. Please contact your 3307740 a Global American sales representative. or visit the [Global American website](#). website www.globalamericaninc.com to find out more about the available chassis.

5.5.3 CPU Card Installation

To install the 3307740 CPU card onto the backplane, carefully align the CPU card interface connectors with the corresponding socket on the backplane. To do this, please refer to the reference material that came with the backplane. Next, secure the CPU card to the chassis. To do this, please refer to the reference material that came with the chassis.

5.6 Internal Peripheral Device Connections

5.6.1 Peripheral Device Cables

The cables listed in **Table 5-6** are shipped with the 3307740.

| Quantity | Type |
|----------|------------------------|
| 1 | IDE Cable |
| 1 | KB/MS cable |
| 2 | SATA drive cables |
| 1 | SATA drive power cable |

Table 5-6: GLOBAL AMERICAN Provided Cables

Optional cables are listed below:

- TV out cable

- LPT cable
- FDD cable
- 5-pin wafer-to-PS/2 cable for mouse or keyboard
- 7.1 channel audio kit
- 5.1 channel audio kit

5.6.2 IDE Cable Connection

The IDE flat cable connects to the 3307740 to one or two IDE devices. To connect an IDE HDD to the 3307740 please follow the instructions below.

Step 1: **Locate the IDE connector.** The location/s of the IDE device connector/s is/are shown in **Chapter 3**.

Step 2: **Insert the connector.** Connect the IDE cable connector to the onboard connector. See **Figure 5-10**. A key on the front of the cable connector ensures it can only be inserted in one direction.

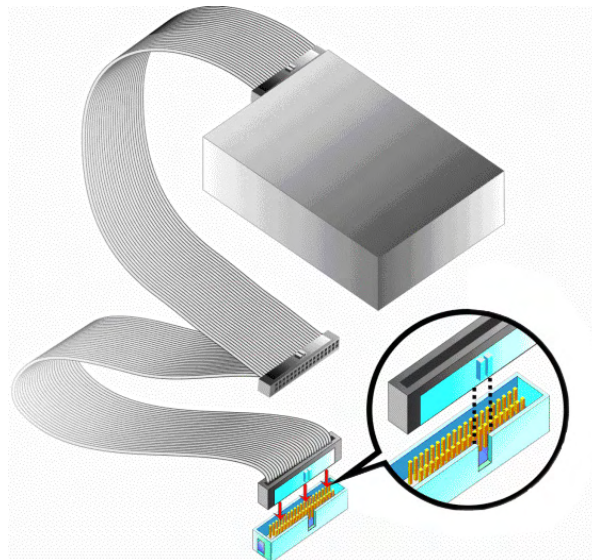

Figure 5-10: IDE Cable Connection

Step 3: **Connect the cable to an IDE device.** Connect the two connectors on the other side of the cable to one or two IDE devices. Make sure that pin 1 on the cable corresponds to pin 1 on the connector

5.6.3 5.1 Channel Audio Kit Installation



NOTE:

This is an optional item that must be ordered separately. For further information please contact the nearest 3307740 distributor, reseller or vendor or contact an Global American sales representative directly.

The optional 5.1 channel audio kit connects to the 10-pin audio connector on the 3307740. The audio kit consists of three audio jacks. One audio jack, Mic In, connects to a microphone. The remaining two audio jacks, Line-In and Line-Out, connect to two speakers. To install the audio kit, please refer to the steps below:

- Step 1: Connect the audio kit cable.** The audio kit is shipped with a cable that connects the audio kit to the 3307740. Connect the cable to the connector on the back of the audio kit. Make sure the pins are properly aligned (i.e. pin 1 connects to pin 1).
- Step 2: Locate the audio connector.** The location of the 10-pin audio connector is shown in **Chapter 3**.
- Step 3: Align pin 1.** Align pin 1 on the onboard connector with pin 1 on the audio kit cable connector. Pin 1 on the audio kit cable connector is indicated with a white dot. See **Figure 5-11**.

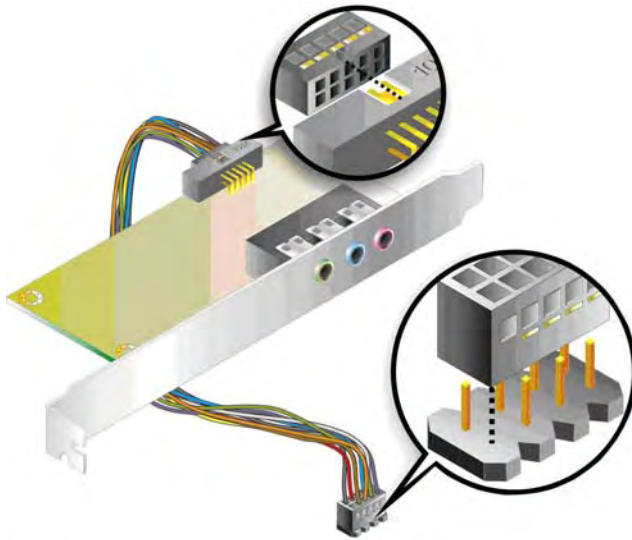

Figure 5-11: 5.1 Channel Audio Kit

Step 4: **Mount the audio kit onto the chassis.** Once the audio kit is connected to the 3307740, secure the audio kit bracket to the system chassis.

Step 5: **Connect the audio devices.** Connect one speaker to the line-in audio jack, one speaker to the line-out audio jack and a microphone to the mic-in audio jack.

Step 6: **Install the driver.** If the 5.1 channel audio kit is used, the ALC655 Realtek codec driver must be installed. Refer to **Chapter 7** for driver installation instructions.

5.6.4 7.1 Channel Audio Kit Installation



NOTE:

This is an optional item that must be ordered separately. For further information please contact the nearest 3307740 distributor, reseller or vendor or contact an Global American sales representative directly.

3307740 PICMG 1.3 CPU Card

The optional 7.1 channel audio kit connects to the 10-pin audio connector on the 3307740. The audio kit consists of five audio jacks. One audio jack, Mic In, connects to a microphone. The remaining four audio jacks, Line-In, Front-Out, Rear-Out, and Center Subwoofer, connect to speakers. To install the audio kit, please refer to the steps below:

- Step 1: Connect the audio kit cable.** The audio kit is shipped with a cable that connects the audio kit to the 3307740. Connect the cable to the connector on the back of the audio kit. Make sure the pins are properly aligned (i.e. pin 1 connects to pin 1).
- Step 2: Locate the audio connector.** The location of the 10-pin audio connector is shown in **Chapter 3**.
- Step 3: Align pin 1.** Align pin 1 on the onboard connector with pin 1 on the audio kit cable connector. Pin 1 on the audio kit cable connector is indicated with a white dot. See **Figure 5-11**.

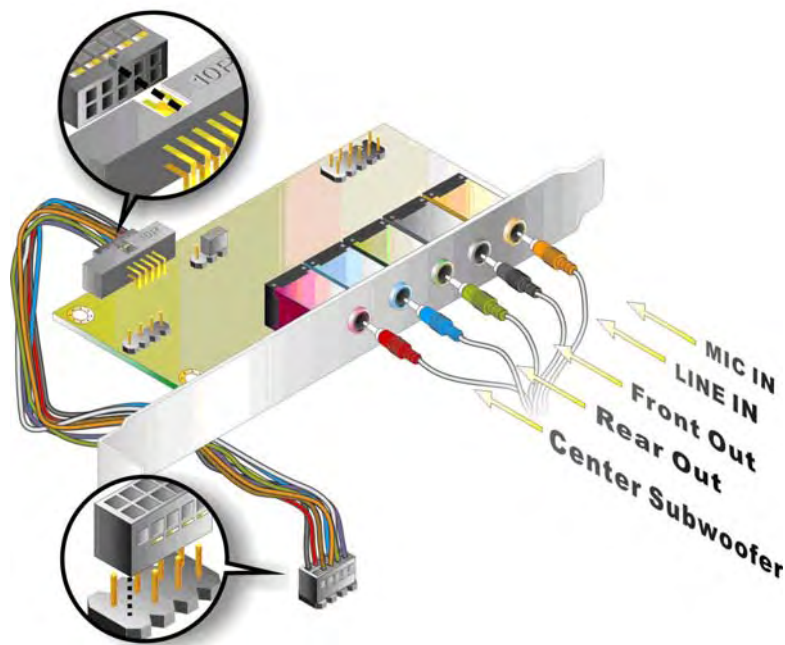

Figure 5-12: 5.1 Channel Audio Kit

- Step 4: Mount the audio kit onto the chassis.** Once the audio kit is connected to the

3307740, secure the audio kit bracket to the system chassis.

Step 5: Connect the audio devices. Connect one speaker to the line-in audio jack, one speaker to the line-out audio jack and a microphone to the mic-in audio jack.

Step 6: Install the driver. If the 5.1 channel audio kit is used, the ALC655 Realtek codec driver must be installed. Refer to **Chapter 7** for driver installation instructions.

5.6.5 FDD Cable Connection

The FDD flat cable connects to the [PRODUCT NAME] to one FDD device. To connect an FDD to the [PRODUCT NAME] please follow the instructions below.

Step 1: Locate the FDD connector. The location of the FDD device connector is shown in **Chapter 3**.

Step 2: Insert the connector. Connect the FDD cable connector to the on-board connector. See **Figure 5-13**. A key on the front of the cable connector ensures it can only be inserted in one direction.



Figure 5-13: FDD Cable Connection

Step 3: **Connect the cable to an FDD device.** Connect the connector at the other end of the cable to an FDD device. Make sure that pin 1 on the cable corresponds to pin 1 on the connector.

5.6.6 Parallel Port Cable

The optional parallel port (LPT) cable respectively connects the onboard LPT 26-pin box header to an external LPT device (like a printer). The cable comprises a 26-pin female header, to be connected to the onboard LPT box-header, on one side and on the other side a standard external LPT connector. To connect the LPT cable, please follow the steps below.

Step 1: **Locate the connector.** The LPT connector location is shown in **Chapter 4**.

Step 2: **Align the connectors.** Correctly align pin 1 on the cable connector with pin 1 on the 3307740 LPT box-header connector. See **Figure 5-14**.

Step 3: **Insert the cable connectors** Once the cable connector is properly aligned with the 26-pin box-header connector on the 3307740, connect the cable connector to the onboard connector. See **Figure 5-14**.

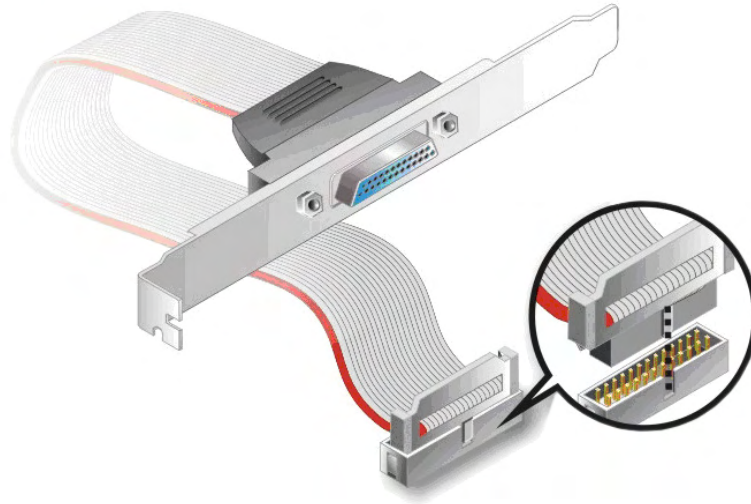

Figure 5-14: LPT Cable Connection

- Step 4:** **Attach the LPT connector bracket to the chassis.** The LPT cable connector is connected to a standard external LPT interface connector. To secure the LPT interface connector to the chassis please refer to the installation instructions that came with the chassis.
- Step 5:** **Connect LPT device.** Once the LPT interface connector is connected to the chassis, the LPT device can be connected to the LPT interface connector. See **Figure 5-15**

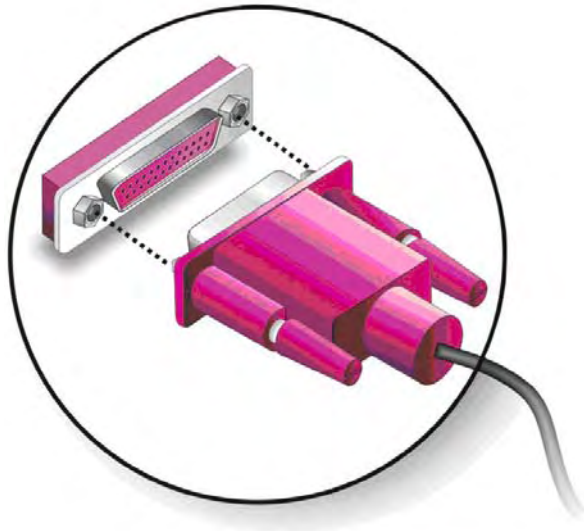

Figure 5-15: Connect the LPT Device

5.6.7 Dual RS-232 Cable Connection

The dual RS-232 cable consists of two connectors attached to two independent cables. Each cable is then attached to a D-sub 9 male connector that is mounted onto a bracket. To install the dual RS-232 cable, please follow the steps below.

- Step 1: Locate the connectors.** The locations of the RS-232 connectors are shown in **Chapter 3**.
- Step 2: Insert the cable connectors.** Insert one connector into each serial port box headers. See **Figure 5-16**. A key on the front of the cable connectors ensures the connector can only be installed in one direction.

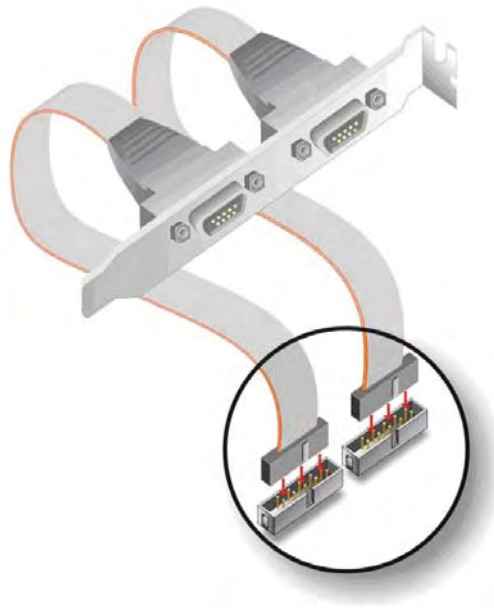

Figure 5-16: Dual RS-232 Cable Installation

Step 3: **Secure the bracket.** The dual RS-232 connector has two D-sub 9 male connectors secured on a bracket. To secure the bracket to the chassis please refer to the reference material that came with the chassis

5.6.8 SATA Drive Connection

The 3307740 is shipped with two SATA drive cables and one SATA drive power cable. To connect the SATA drives to the connectors, please follow the steps below.

Step 1: **Locate the connectors.** The locations of the SATA drive connectors are shown in **Chapter 3**.

Step 2: **Insert the cable connector.** Press the clip on the connector at the end of the SATA cable and insert the cable connector into the onboard SATA drive connector. See **Figure 5-17**.

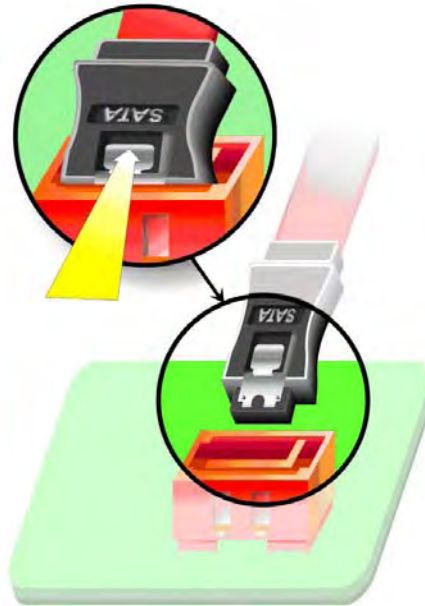

Figure 5-17: SATA Drive Cable Connection

Step 3: Connect the cable to the SATA disk. Connect the connector on the other end of the cable to the connector at the back of the SATA drive. See **Figure 5-18**.

Step 4: Connect the SATA power cable. Connect the SATA power connector to the back of the SATA drive. See **Figure 5-18**.



Figure 5-18: SATA Power Drive Connection

5.6.9 Wafer-to-PS/2 Cable (Keyboard/Mouse Installation)

The optional wafer-to-PS/2 cable respectively connects the onboard keyboard wafer connector and the onboard mouse wafer connector to a PS/2 keyboard and a PS/2 mouse. To connect the wafer-to-PS/2 cable, please follow the steps below.

Step 1: Locate the connector. The location of the keyboard/mouse connector is shown in **Chapter 4**.

Step 2: Align the connectors. Correctly align pin 1 on the cable connector with pin 1 on the 3307740 keyboard or mouse connector. See **Figure 5-19**.

Step 3: Insert the cable connectors Once the cable connector is properly aligned with the keyboard/mouse connector on the 3307740, connect the cable connector to the onboard connectors. See **Figure 5-19**.

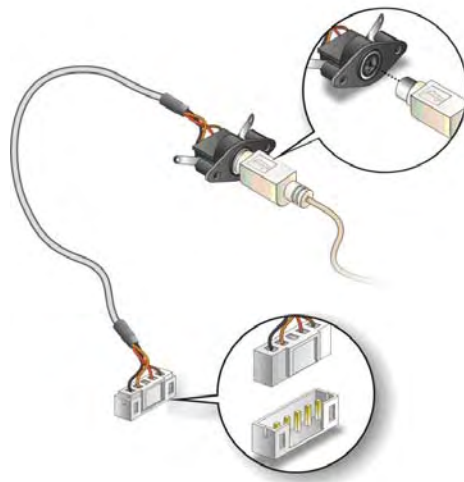

Figure 5-19: Keyboard/mouse Cable Connection

Step 4: Attach PS/2 connector to the chassis. The wafer-to-PS/2 cable connector is connected to a PS/2 connector. To secure the PS/2 connector to the chassis please refer to the installation instructions that came with the chassis.

3307740 PICMG 1.3 CPU Card

Step 5: Connect the keyboard or mouse. Once the PS/2 connector is connected to the chassis, the wafer-to-PS/2 cable connected to the keyboard connector can be connected to the PS/2 connector on a keyboard and the wafer-to-PS/2 cable connected to the mouse connector can be connected to the PS/2 connector on a PS/2 mouse.

5.7 External Peripheral Interface Connection

The following external peripheral devices can be connected to the external peripheral interface connectors.

- VGA monitors
- RJ-45 Ethernet cable connectors
- USB devices

To install these devices, connect the corresponding cable connector from the actual device to the corresponding 3307740 external peripheral interface connector making sure the pins are properly aligned.

5.7.1 LAN Connection (Single Connector)

There are two external RJ-45 LAN connectors. The RJ-45 connectors enable connection to an external network. To connect a LAN cable with an RJ-45 connector, please follow the instructions below.

Step 1: Locate the RJ-45 connectors. The locations of the USB connectors are shown in **Chapter 4**.

Step 2: Align the connectors. Align the RJ-45 connector on the LAN cable with one of the RJ-45 connectors on the 3307740. See **Figure 5-20**.

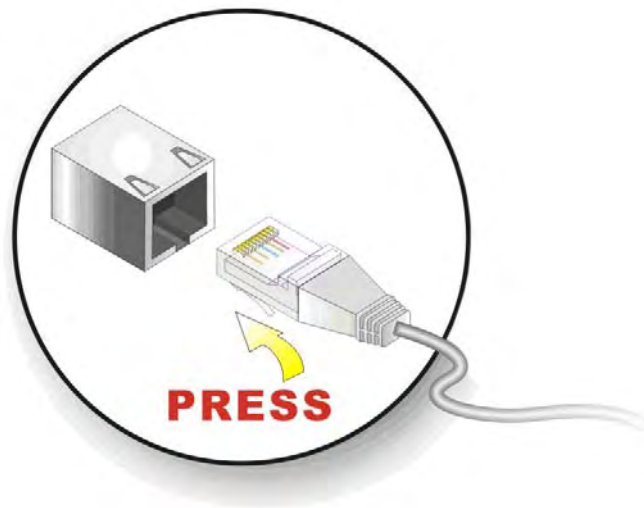

Figure 5-20: LAN Connection

Step 3: Insert the LAN cable RJ-45 connector. Once aligned, gently insert the LAN cable RJ-45 connector into the onboard RJ-45 connector.

5.7.2 USB Device Connection (Single Connector)

There are two external USB 2.0 connectors. Both connectors are perpendicular to the 3307740. To connect a USB 2.0 or USB 1.1 device, please follow the instructions below.

Step 1: Located the USB connectors. The locations of the USB connectors are shown in Chapter 4.

Step 2: Align the connectors. Align the USB device connector with one of the connectors on the 3307740. See Figure 5-20.

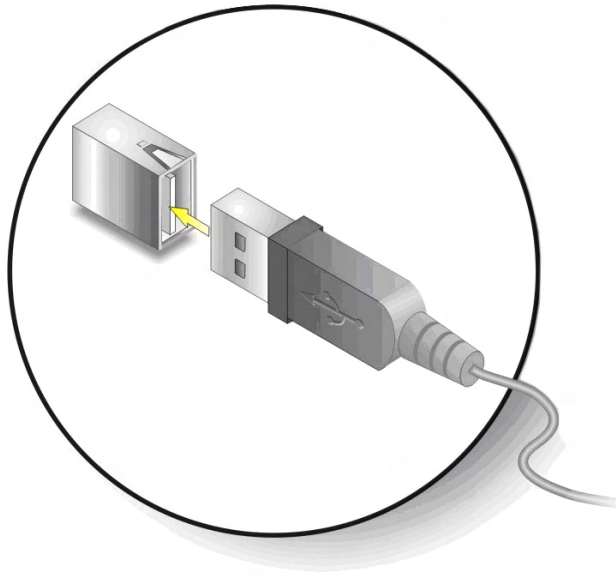

Figure 5-21: USB Device Connection

Step 3: **Insert the device connector.** Once aligned, gently insert the USB device connector into the onboard connector.

5.7.3 VGA Monitor Connection

The 3307740 has a single female DB-15 connector on the external peripheral interface panel. The DB-15 connector is connected to a CRT or VGA monitor. To connect a monitor to the 3307740, please follow the instructions below.

- Step 1:** **Locate the female DB-15 connector.** The location of the female DB-15 connector is shown in **Chapter 3**.
- Step 2:** **Align the VGA connector.** Align the male DB-15 connector on the VGA screen cable with the female DB-15 connector on the external peripheral interface.
- Step 3:** **Insert the VGA connector** Once the connectors are properly aligned with the insert the male connector from the VGA screen into the female connector on the

3307740. See **Figure 5-22**.

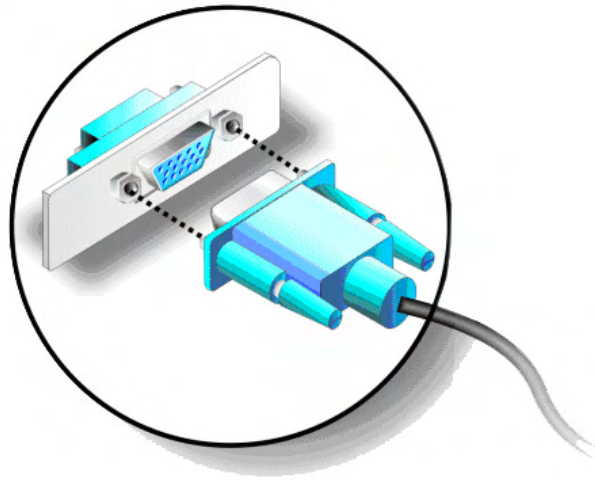

Figure 5-22: VGA Connector

Step 4: **Secure the connector.** Secure the DB-15 VGA connector from the VGA monitor to the external interface by tightening the two retention screws on either side of the connector.

Appendix

A

DIO Interface

A.1 DIO Interface Introduction

The DIO connector on the 3307740 is interfaced to GIO ports on the iTE Super I/O chipset. The DIO has both 4-bit digital inputs and 4-bit digital outputs. The digital inputs and digital outputs are generally control signals that control the on/off circuit of external devices or TTL devices. Data can be read or written to the selected address to enable the DIO functions.



NOTE:

For further information, please refer to the datasheet for the iTE Super I/O chipset.

A.2 DIO Connector Pinouts

The following table describes how the GPIO connector pins are connected to the Super I/O GPIO port 1.

| Pin | Description | Super I/O Pin | Super I/O Pin Description |
|-----|-------------|---------------|-----------------------------------|
| 1 | Ground | N/A | N/A |
| 2 | VCC | N/A | N/A |
| 3 | XIN0 | 27 (GP20) | General purpose I/O port 2 bit 0. |
| 4 | XOUT0 | 23 (GP24) | General purpose I/O port 2 bit 4. |
| 5 | XIN1 | 26 (GP21) | General purpose I/O port 2 bit 1. |
| 6 | XOUT1 | 22 (GP25) | General purpose I/O port 2 bit 5. |
| 7 | XIN2 | 25 (GP22) | General purpose I/O port 2 bit 3. |
| 8 | XOUT2 | 21 (GP26) | General purpose I/O port 2 bit 2. |
| 9 | XIN3 | 24 (GP23) | General purpose I/O port 2 bit 6. |
| 10 | XOUT3 | 20 (GP27) | General purpose I/O port 2 bit 7. |

A.3 Assembly Language Samples

A.3.1 Enable the DIO Input Function

The BIOS interrupt call INT 15H controls the digital I/O. An assembly program to enable digital I/O input functions is listed below.

| | | |
|------------|------------------|---------------------------------|
| MOV | AX, 6F08H | Sets the digital port as input |
| INT | 15H | Initiates the INT 15H BIOS call |

A.3.2 Enable the DIO Output Function

The BIOS interrupt call INT 15H controls the digital I/O. An assembly program to enable digital I/O output functions is listed below.

| | | |
|------------|------------------|---------------------------------|
| MOV | AX, 6F09H | Sets the digital port as output |
| MOV | BL, 09H | |
| INT | 15H | Initiates the INT 15H BIOS call |

THIS PAGE IS INTENTIONALLY LEFT BLANK

Appendix

B

Watchdog Timer



NOTE:

The following discussion applies to DOS environment. GLOBAL AMERICAN support is contacted or the GLOBAL AMERICAN website visited for specific drivers for more sophisticated operating systems, e.g., Windows and Linux.

The Watchdog Timer is provided to ensure that standalone systems can always recover from catastrophic conditions that cause the CPU to crash. This condition may have occurred by external EMI or a software bug. When the CPU stops working correctly, Watchdog Timer either performs a hardware reset (cold boot) or a Non-Maskable Interrupt (NMI) to bring the system back to a known state.

A BIOS function call (INT 15H) is used to control the Watchdog Timer:

INT 15H:

| AH – 6FH Sub-function: | |
|-------------------------------|---|
| AL – 2: | Sets the Watchdog Timer's period. |
| BL: | Time-out value (Its unit-second is dependent on the item "Watchdog Timer unit select" in CMOS setup). |

Table B-1: AH-6FH Sub-function

Call sub-function 2 to set the time-out period of Watchdog Timer first. If the time-out value is not zero, the Watchdog Timer starts counting down. While the timer value reaches zero, the system resets. To ensure that this reset condition does not occur, calling sub-function 2 must periodically refresh the Watchdog Timer. However, the Watchdog timer is disabled if the time-out value is set to zero.

A tolerance of at least 10% must be maintained to avoid unknown routines within the operating system (DOS), such as disk I/O that can be very time-consuming.



NOTE:

When exiting a program it is necessary to disable the Watchdog Timer, otherwise the system resets.

Example program:

; INITIAL TIMER PERIOD COUNTER

;

W_LOOP:

```
MOV    AX, 6F02H    ;setting the time-out value
MOV    BL, 30       ;time-out value is 48 seconds
INT    15H
```

;

; ADD THE APPLICATION PROGRAM HERE

;

```
CMP    EXIT_AP, 1   ;is the application over?
JNE    W_LOOP       ;No, restart the application
```

```
MOV    AX, 6F02H    ;disable Watchdog Timer
MOV    BL, 0        ;
INT    15H
```

;

; EXIT ;

Appendix

C

Address Mapping

C.1 Address Map

| I/O address Range | Description |
|-------------------|---------------------------------|
| 000-01F | DMA Controller |
| 020-021 | Interrupt Controller |
| 040-043 | System time |
| 060-06F | Keyboard Controller |
| 070-07F | System CMOS/Real time Clock |
| 080-09F | DMA Controller |
| 0A0-0A1 | Interrupt Controller |
| 0C0-0DF | DMA Controller |
| 0F0-0FF | Numeric data processor |
| 1F0-1F7 | Primary IDE Channel |
| 2F8-2FF | Serial Port 2 (COM2) |
| 378-37F | Parallel Printer Port 1 (LPT1) |
| 3B0-3BB | Intel Graphics Controller |
| 3C0-3DF | Intel Graphics Controller |
| 3F6-3F6 | Primary IDE Channel |
| 3F7-3F7 | Standard floppy disk controller |
| 3F8-3FF | Serial Port 1 (COM1) |

Table C-1: IO Address Map

C.2 1st MB Memory Address Map

| Memory address | Description |
|----------------|---------------|
| 00000-9FFFF | System memory |
| A0000-BFFFF | VGA buffer |
| F0000-FFFFF | System BIOS |
| 1000000- | Extend BIOS |

Table C-2: 1st MB Memory Address Map

C.3 IRQ Mapping Table

| IRQ0 | System Timer | IRQ8 | RTC clock |
|------|------------------|-------|-----------------|
| IRQ1 | Keyboard | IRQ9 | ACPI |
| IRQ2 | Available | IRQ10 | LAN |
| IRQ3 | COM2 | IRQ11 | LAN/USB2.0/SATA |
| IRQ4 | COM1 | IRQ12 | PS/2 mouse |
| IRQ5 | SMBus Controller | IRQ13 | FPU |
| IRQ6 | FDC | IRQ14 | Primary IDE |
| IRQ7 | Available | IRQ15 | Secondary IDE |

Table C-3: IRQ Mapping Table

C.4 DMA Channel Assignments

| Channel | Function |
|---------|------------------------------|
| 0 | Available |
| 1 | Available |
| 2 | Floppy disk (8-bit transfer) |
| 3 | Available |
| 4 | Cascade for DMA controller 1 |
| 5 | Available |
| 6 | Available |
| 7 | Available |

Table C-4: IRQ Mapping Table

Any advice or comments about our products and service, or anything we can help you with please don't hesitate to contact with us. We will do our best to support your products, projects and business.



Address: Global American, Inc.
17 Hampshire Drive
Hudson, NH 03051

Telephone: Toll Free U.S. Only (800) 833-8999
(603) 886-3900

FAX: (603) 886-4545

Website: <http://www.globalamericaninc.com>

Support: Technical Support at Global American
