



integration with integrity

3307700 User's Manual

Copyrights

This document is copyrighted and all rights are reserved. It does not allow any non authorization in copied, photocopied, translated or reproduced to any electronic or machine readable form in whole or in part without prior written consent from the manufacturer.

In general, the manufacturer will not be liable for any direct, indirect, special, incidental or consequential damages arising from the use of inability to use the product or documentation, even if advised of the possibility of such damages. The manufacturer keeps the rights in the subject to change the contents of this document without prior notices in order to improve the function design, performance, quality and reliability. The author assumes no responsibility for any errors or omissions, which may appear in this document, nor does it make a commitment to update the information contained herein.

Trademarks

Intel is a registered trademark of Intel Corporation.

Award is a registered trademark of Award Software, Inc.

All other trademarks, products and or product's name mentioned herein are mentioned for identification purposes only, and may be trademarks and/or registered trademarks of their respective companies or owners.

Table of Contents

Chapter 1	General Description	1
1.1	Major Features	2
1.2	Specifications	3
1.3	Board Dimensions.....	4
Chapter 2	Unpacking	5
2.1	Opening the Delivery Package.....	5
2.2	Inspection.....	5
Chapter 3	Hardware Installation	7
3.1	Before Installation	7
3.2	Board Layout	8
3.3	Jumper List	9
3.4	Connector List	9
3.5	Configuring the CPU	10
3.6	System Memory	10
3.7	VGA Controller	10
3.8	PCI E-IDE Drive Connector	12
3.9	Serial Port Connectors	13
3.10	Ethernet Connector.....	14
3.11	USB Connector	15
3.12	CMOS Data Clear	16
3.13	Power and Fan Connectors.....	16
3.14	Keyboard/Mouse Connectors	17
3.15	System Front Panel Control	17
3.16	Watchdog Timer	18
3.17	Audio Connectors	19
3.18	CompactFlash™ Connector.....	19
3.19	Mini PCI Slot.....	20
3.20	8-bit I/O Function	20

Safety Instructions

Integrated circuits on computer boards are sensitive to static electricity. To avoid damaging chips from electrostatic discharge, observe the following precautions:

- Do not remove boards or integrated circuits from their anti-static packaging until you are ready to install them.
- Before handling a board or integrated circuit, touch an unpainted portion of the system unit chassis for a few seconds. This helps to discharge any static electricity on your body.
- Wear a wrist-grounding strap, available from most electronic component stores, when handling boards and components. Fasten the ALLIGATOR clip of the strap to the end of the shielded wire lead from a grounded object. Please wear and connect the strap before handle the product to ensure harmlessly discharge any static electricity through the strap.
- Please use an anti-static pad when putting down any components or parts or tools outside the computer. You may also use an anti-static bag instead of the pad. Please inquire from your local supplier for additional assistance in finding the necessary anti-static gadgets.

NOTE: *DO NOT TOUCH THE BOARD OR ANY OTHER SENSITIVE COMPONENTS WITHOUT ALL NECESSARY ANTI-STATIC PROTECTIONS.*



Chapter 1

General Description

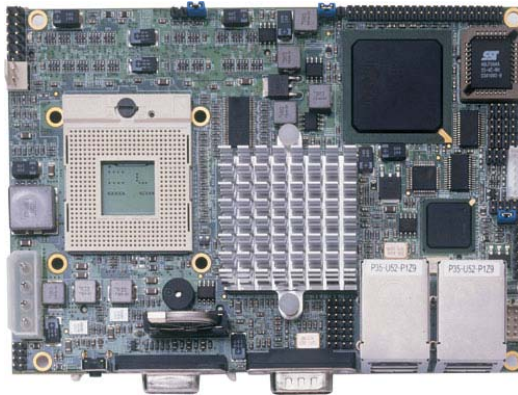

The 3307700 is an Intel 852GM/GME GMCH chipset-based design. The 3307700 is ideal all-in-one embedded engine board. Additional features include an enhanced I/O with CF, CRT/LVDS, dual LAN, audio, 4 COM, and USB2.0 interfaces.

Its onboard ATA/33/66/100 to IDE drive interface architecture allows the 3307700 to support data transfers of 33, 66 or 100MB/sec to one IDE drive connection. The 3307700 supports Intel Pentium M/ Celeron M processor, and 3307700 supports ULV Intel Celeron M M processor 600MHz/512K.

The Intel 852GM/GME with 8MB shared memory supporting CRT display up to 1600 x 1200. It also supports 18-bit single channel/36-bit dual channel LVDS interface.

System memory is also sufficient with the one SO-DDR socket that can support up to 1GB.

Additional onboard connectors include an advanced USB2.0 port providing faster data transmission. And two external RJ-45 connectors for 10/100 Based Ethernet use.

To ensure the reliability in an unmanned or standalone system, the watchdog timer (WDT) onboard 3307700 is designed with software that does not need the arithmetical functions of a real-time clock chip. If any program causes unexpected halts to the system, the onboard WDT will automatically reset the CPU or generate an interrupt to resolve such condition.

1.1 Major Features

The 3307700 comes with the following features:

- Intel® Pentium® M/Celeron® M processor 1.3~2.0GHz (3307700B,C,D,E)
ULV Intel® Celeron® M processor 600MHz/512K (3307700A)
- Supports 533MHz FSB (3307700B,C,D,E)
- One SO-DDR socket with a max. capacity of 1GB
- Intel® 852GM/GME GMCH/ICH4 system chipset
- Winbond W83627HF super I/O chipset
- Intel® 82852GM/GME graphics controller
- 18-bit/36-bit LVDS Panel display interface
- Intel® 82551QM and 82562ET fast Ethernet controller
- AC97 3D audio controller
- Fast PCI ATA/33/66/100 IDE controller
- CF card adapter, 4 COM, 6 USB2.0
- Single +5V power in
- Hardware Monitor function

1.2 Specifications

- **CPU:**
3307700B,C,D,E provides
Intel® Pentium® M processor 760 2.0GHz
Intel® Pentium® M processor 745 1.8GHz
Intel® Celeron® M processor 370 1.5GHz
Intel® Celeron® M processor 320 1.3GHz
3307700A provides ULV Intel® Celeron® M processor 600MHz/512K
- **Front Side Bus:**
3307700B,C,D,E supports 400/533MHz FSB
3307700A supports 400MHz FSB
- **Memory:** One SO-DDR socket supporting up to 1GB
- **Chipset:**
Intel® 852GM/GME GMCH/ICH4
- **I/O Chipset:** Winbond W83627HF
- **CompactFlash:** One, Type I/II IDE interface adapter
- **PCI Slot:** One, Type III mini PCI slot
- **VGA:** Intel® 82852GM/GME for CRT display with 8MB shared main memory supporting up to 1600 x 1200
- **LVDS Panel:** Supports 18-bit single channel/36-bit dual channel LVDS interface
- **Ethernet:** Intel® 82551QM and 82562ET 10/100 Based LAN
- **Audio:** AC97 3D audio controller
- **IDE:** One 2.0-pitch 44-pin IDE connector
- **Serial Port:** 16C550 UART-compatible RS-232/422/485 x 1 and RS-232 x 3 serial ports with 16-byte FIFO
- **USB:** 6 USB2.0 ports, internal x 2 and external x 4
- **Keyboard/Mouse:** 6-pin connector
- **BIOS:** AMI PnP Flash BIOS
- **Watchdog Timer:** Software programmable time-out intervals from 1~256 sec.
- **CMOS:** Battery backup
- **Power In:** Single +5V power in
- **Hardware Monitor:** Winbond W83627HF
- **Board Size:** 14.5(L) x 10.2(W) cm

1.3 Board Dimensions

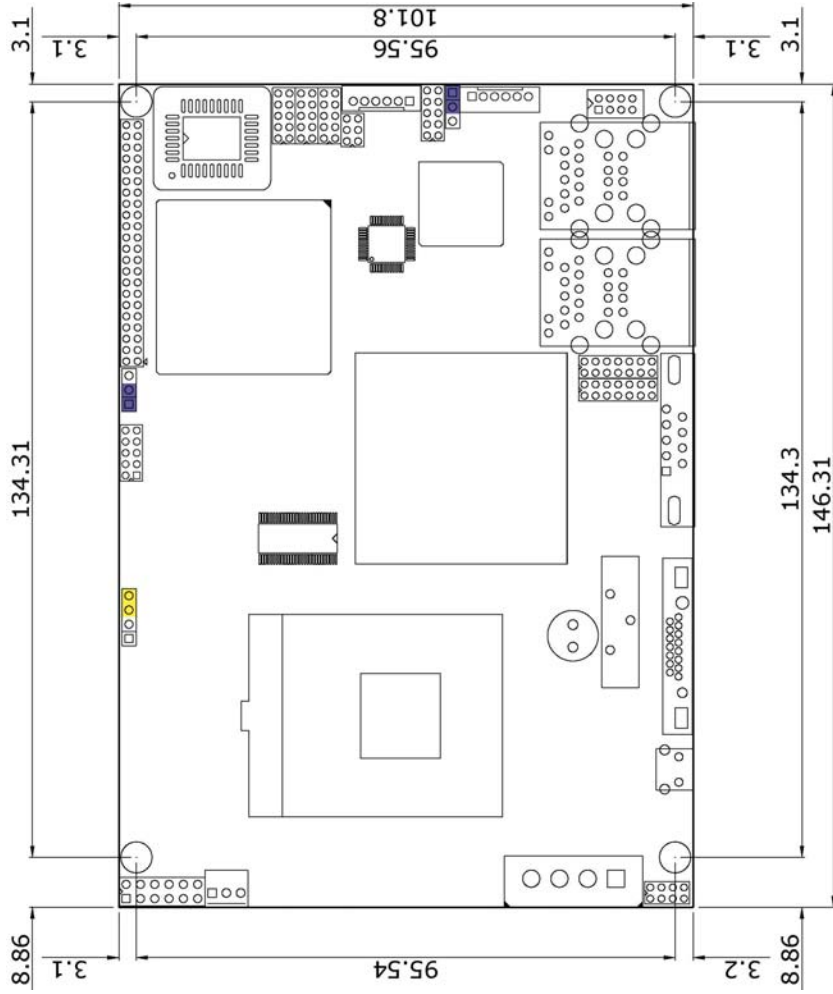

Chapter 2

Unpacking

2.1 Opening the Delivery Package

The 3307700 is packed in an anti-static bag. The board has components that are easily damaged by static electricity. Do not remove the anti-static wrapping until proper precautions have been taken. Safety Instructions in front of this manual describe anti-static precautions and procedures.

2.2 Inspection

After unpacking the board, place it on a raised surface and carefully inspect the board for any damage that might have occurred during shipment. Ground the board and exercise extreme care to prevent damage to the board from static electricity.

Integrated circuits will sometimes come out of their sockets during shipment. Examine all integrated circuits, particularly the BIOS, processor, memory modules, ROM-Disk, and keyboard controller chip to ensure that they are firmly seated. The 3307700 delivery package contains the following items:



Cables Package		
NO.	Description	QTY.
1	6P(JST2.0) Mini DIN * 2	1
2	SPK 8P(2.0)-Phone Jack * 2	1
3	COM DB9-10P (2.0-pitch)	1
4	40-pin to 44-pin IDE flat cable	1
5	2-pin to 4-pin power cable	1

It is recommended that you keep all the parts of the delivery package intact and store them in a safe/dry place for any unforeseen event requiring the return shipment of the product. In case you discover any missing and/or damaged items from the list of items, please contact your dealer immediately.

Option Accessories	
NO.	Description
1	1-to-2 USB cable with bracket
2	COM DB9-10P (2.0-pitch)

Chapter 3

Hardware Installation

This chapter provides the information on how to install the hardware using the 3307700. This chapter also contains information related to jumper settings of switch, and watchdog timer selection etc.

3.1 Before Installation

After confirming your package contents, you are now ready to install your hardware. The following are important reminders and steps to take before you begin with your installation process.

1. Make sure that all jumper settings match their default settings and CMOS setup correctly. Refer to the sections on this chapter for the default settings of each jumper. (set JP2 1-2)
2. Go through the connections of all external devices and make sure that they are installed properly and configured correctly within the CMOS setup. Refer to the sections on this chapter for the detailed information on the connectors.
3. Keep the manual and diskette in good condition for future reference and use.

3.2 Board Layout

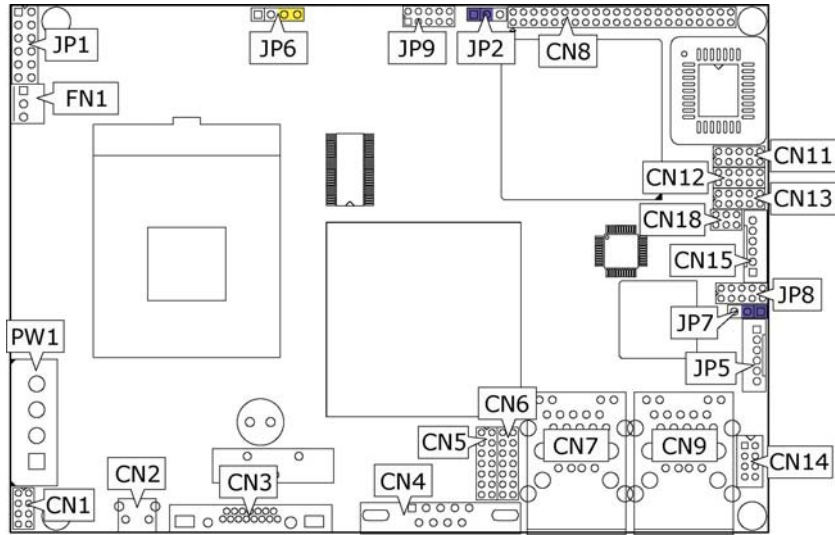

Top Side

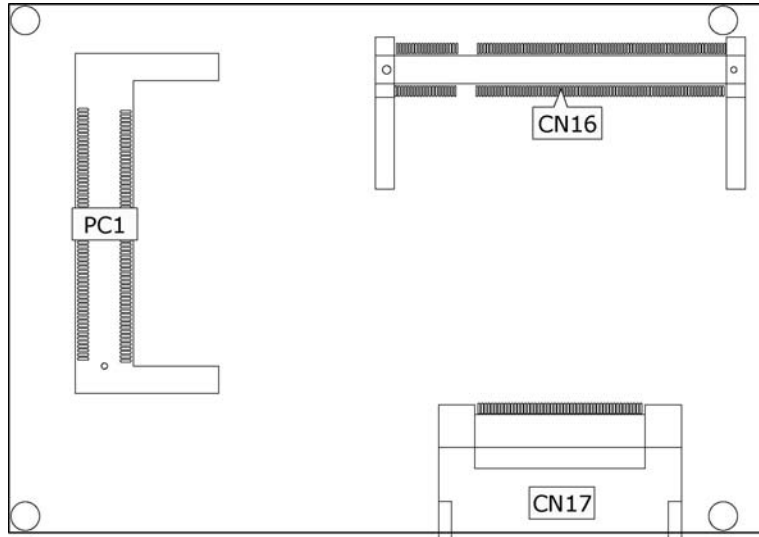

Solder Side

3.3 Jumper List

Jumper	Default Setting	Setting	Page
JP2	Clear CMOS: <i>Normal Operation</i>	Short 1-2	16
JP6	System Frequency Select: <i>400MHz</i>	Short 3-4	10
JP7	Onboard LAN 2 Enabled/Disabled Select: <i>Enabled</i>	Short 1-2	14
JP8	COM4 Use RS-232 or RS-422/485 Select: <i>RS-232</i>	Open	13

3.4 Connector List

Connector	Definition	Page
CN1	MIC In/Line Out Connector	19
CN2	External Reset Button	----
CN3	15-pin CRT Connector	10
CN4	COM 1 (DB9)	13
CN5/CN6	LVDS Panel Connector	10
CN7/CN9	RJ-45 & Dual USB2.0 Port	14/15
CN8	IDE Connector	12
CN11/CN12/CN13	COM 2~COM 4 Connector (5x2 header)	13
CN14	Internal USB2.0 Port	15
CN15	6-pin KB/MS Connector	17
CN16	SO-DDR Socket	10
CN17	CompactFlash Connector	19
CN18	RS-422/485 Connector	13
FN1	Fan Power In Connector	16
PW1	4-pin Power In Connector	16
JP1	System Front Panel Control	17
JP5	Inverter Power In Connector	10
JP9	8-bit I/O Connector	20
PC1	Mini PCI Slot	20

3.5 Configuring the CPU

The 3307700B provides Intel® Pentium® M processor 760 2.0GHz, Pentium® M processor 745 1.8GHz, Celeron® M processor 370 1.5GHz, and Celeron® M processor 1.3GHz. The 3307700A embedded with ULV Intel® Celeron® M processor 600MHz/512K. If you want to use 533MHz FSB processor, please set *JP6*, and *JP6* is only for 3307700.

- **JP6: System Frequency Select**

Options	Settings
533MHz FSB	All Open
400MHz FSB (default)	Short 3-4



3.6 System Memory

The 3307700 provides one SO-DDR socket at locations *CN16*. The maximum capacity of the onboard memory is 1GB.

3.7 VGA Controller

The 3307700 provides two connection methods of a VGA device. *CN3* offers a single standard CRT connector and *CN5/CN6* are the LVDS interface connectors onboard reserved for flat panel installation.

- **CN3: CRT Connector**

PIN	Description	PIN	Description
1	Red	2	Green
3	Blue	4	N/C
5	GND	6	GND
7	GND	8	GND
9	N/C	10	GND
11	N/C	12	SDA
13	HSYNC	14	VSYNC
15	SCL		

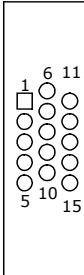

● **CN5/CN6: LVDS Interface Connector**

PIN	Description	PIN	Description
1	V _{LCD}	2	V _{LCD}
3	GND	4	GND
5	A0-/A4-	6	A0+/A4+
7	A1-/A5-	8	A1+/A5+
9	A2-/A6-	10	A2+/A6+
11	CLK1-/CLK2-	12	CLK1+/CLK2+
13	N/C	14	N/C

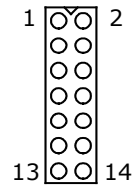

NOTE: LVDS cable should be produced very carefully. A0- & A0+ have to be fabricated in twister pair (A1- & A1+, A2- & A2+ and so on) otherwise the signal won't be stable.

NOTE: If use CN5 only, it just supports 18-bit single channel LVDS panel; If you want to use 36-bit dual channel LVDS panel, please use CN5 and CN6 combined.

● **JP5: Inverter Power In Connector**

PIN	Description
1	+12V
2	+12V
3	VCC5
4	BK_EN
5	LCD_EN
6	GND



3.8 PCI E-IDE Drive Connector

CN8 is a standard 44-pin 2.0-pitch connector daisy-chain driver connector serves the PCI E-IDE drive provisions onboard the 3307700. A maximum of two ATA/33/66/100 IDE drives can be connected to the 3307700 via CN8.

- **CN8: IDE Connector**

PIN	Description	PIN	Description
1	Reset	2	GND
3	DATA 7	4	DATA 8
5	DATA 6	6	DATA 9
7	DATA 5	8	DATA 10
9	DATA 4	10	DATA 11
11	DATA 3	12	DATA 12
13	DATA 2	14	DATA 13
15	DATA 1	16	DATA 14
17	DATA 0	18	DATA 15
19	GND	20	N/C
21	PDREQ	22	GND
23	IOW#	24	GND
25	IOR#	26	GND
27	PIORDY	28	PR1PD1-
29	RPDACK-	30	GND
31	Interrupt	32	N/C
33	RPDA1-	34	PATA66
35	RPDA0-	36	RPDA2-
37	RPCS1-	38	RPCS3-
39	HDD Active	40	GND
41	VCC	42	VCC
43	GND	44	N/C

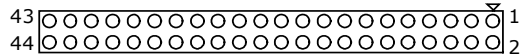

If you want to use ATA/66/100 IDE device, please purchase this cable separately.

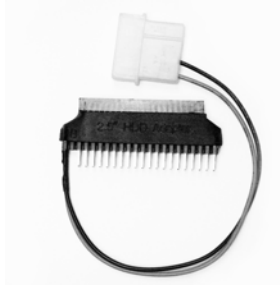

Optional Cable	
Description	
	ATA/66/100 IDE cable for 2.0-pitch IDE connector

3.9 Serial Port Connectors

The 3307700 offers NS16C550 compatible UARTs with Read/ Receive 16-byte FIFO serial ports and internal 10-pin headers and RS-422/485 connector.

- **CN4: COM 1 Connector (DB9)**

PIN	Description	PIN	Description
1	DCD	6	DSR
2	RXD	7	RTS
3	TXD	8	CTS
4	DTR	9	RI
5	GND		

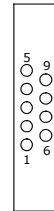

- **CN11/CN12/CN13: COM 2~COM 4 Connector (5x2 Header)**

PIN	Description	PIN	Description
1	DCD	2	DSR
3	RXD	4	RTS
5	TXD	6	CTS
7	DTR	8	RI
9	GND	10	N/C

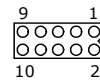

- **CN18: RS-422/485 Connector (3x2 Header, COM4)**

PIN	Description	PIN	Description
1	TX-	2	TX+
3	RX+	4	RX-
5	GND	6	VCC



NOTE: The terminal resistance of RX & TX is set at 180 Ω.

- **JP8: COM 4 use RS-232 or RS-422/485 Select**

Options	Settings
RS-232 (default)	Open
RS-485 by Auto (*1)	Short 1-2, 3-4, 5-7, 8-10
RS-485 by -RTS (*-1)	Short 1-2, 3-4, 7-9, 8-10
RS-422/485 Full Duplex (*2)	Short 1-2, 3-4, 6-8

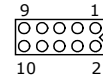

NOTE: *1: 2-wires RS-485 function

*2: 4-wires point-to-point full duplex function

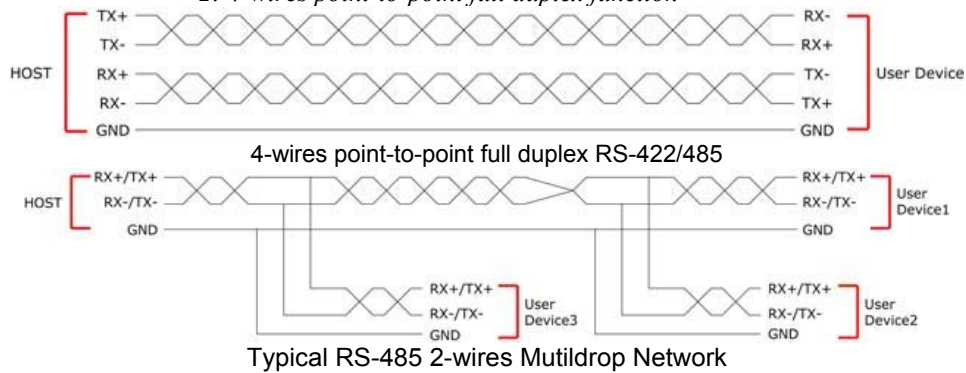

3.10 Ethernet Connector

The 3307700 provides two external RJ-45 interface connectors. Please refer to the following for its pin information.

- **CN7A/CN9A: RJ-45 Connector**

PIN	Description
1	TX+
2	TX-
3	RX+
4	R/C GND
5	R/C GND
6	RX-
7	R/C GND
8	R/C GND

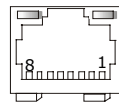

- **JP7: Onboard LAN 2 Enabled/Disabled Select**

Options	Settings
Enabled (default)	Short 1-2
Disabled	Short 2-3



3.11 USB Connector

The 3307700 provides one 8-pin connectors, at location CN14, for two USB ports, and four external USB2.0 ports at CN7B/CN9B.

- **CN7B/CN9B: External USB2.0 Connector**

PIN	Description	PIN	Description
1	VCC	2	VCC
3	USBD0-/USB2-	4	USBD1-/USB3-
5	USBD0+/USB2+	6	USBD1+/USB3+
7	GND	8	GND

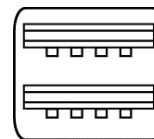

- **CN14: Internal USB2.0 Connector**

PIN	Description	PIN	Description
1	VCC	2	VCC
3	USBD4-	4	USBD5-
5	USBD4+	6	USBD5+
7	GND	8	GND



3.12 CMOS Data Clear

The 3307700 has a Clear CMOS jumper on *JP2*.

- **JP2: Clear CMOS**

Options	Settings
Normal Operation (default)	Short 1-2
Clear CMOS	Short 2-3



IMPORTANT: Before you turn on the power of your system, please set *JP2* to Short 1-2 for normal operation.

3.13 Power and Fan Connectors

3307700 provides one 4-pin power in at *PW1*.

- **PW1: 4-pin Power In Connector**

PIN	Description
1	VCC
2	GND
3	GND
4	+12V

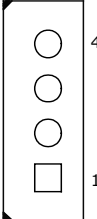

- **FN1: Fan Power In Connector**

PIN	Description
1	GND
2	+5V
3	N/C

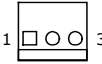

Connector *FN1* onboard 3307700 is a 3-pin fan power output connector. And 3307700 supports +5V Fan only.

3.14 Keyboard/Mouse Connectors

The 3307700 offers CN15 for an internal 6-pin cable converter to keyboard/mouse.

- **CN15: 6-pin Keyboard/Mouse Connector**

PIN	Description
1	Keyboard Data
2	Mouse Data
3	GND
4	VCC
5	Keyboard Clock
6	Mouse Clock



3.15 System Front Panel Control

The 3307700 has system front panel control at location JP1.

- **JP1: System Front Panel Control**

PIN	Description	PIN	Description
1	220Ω pull VCC	2	Speaker
3	HDD LED	4	N/C
5	N/C	6	GND
7	N/C	8	220Ω pull VCC
9	Reset Switch	10	220Ω pull VCC
11	GND	12	GND

Connector JP1 Orientation

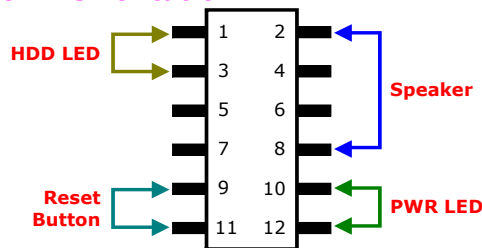

3.16 Watchdog Timer

Once the Enable cycle is active a Refresh cycle is requested before the time-out period. This restarts counting of the WDT period. When the time counting goes over the period preset of WDT, it will assume that the program operation is abnormal. A system reset signal will restart when such error happens.

The following sample programs show how to enable, disable and refresh the watchdog timer:

```
-----  
;Enter the WDT function mode, interruptible double-write  
-----  
      MOV     DX, 2EH  
      MOV     AL, 87H  
      OUT     DX, AL  
      OUT     DX, AL  
      MOV     DX, 2EH  
      MOV     AL, 07H  
      OUT     DX, AL  
      MOV     DX, 2FH  
      MOV     AL, 08H  
      OUT     DX, AL  
      MOV     DX, 2EH  
      MOV     AL, F5H  
      OUT     DX, AL           ;select CRF0  
      MOV     DX, 2FH  
      MOV     AL, 80H  
      OUT     DX, AL  
      MOV     DX, 2EH  
      MOV     AL, F7H  
      OUT     DX, AL  
      MOV     DX, 2FH  
  
      MOV     AL, 00H  
      OUT     DX, AL  
      MOV     DX, 2EH  
      MOV     AL, F6H  
      OUT     DX, AL  
      MOV     DX, 2FH  
      MOV     AL, 00H           ; *00H=Disabled  
      OUT     DX, AL  
  
-----  
;Exit extended function mode  
-----  
      MOV     DX, 2EH  
      MOV     AL, AAH  
      OUT     DX, AL
```

User can also use AL, 00H's defined time for reset purposes, e.g.00H for Disable, 01H = 1sec, 02H=2sec....FFH=255sec.

3.17 Audio Connectors

The 3307700 has an onboard AC97 3D audio controller. The following tables list the pin assignments of the Line In/Audio Out connector.

- **CN1: MIC In/Line Out Connector**

PIN	Description	PIN	Description
1	AOUTL	2	AOUTR
3	GND	4	GND
5	MIC IN	6	N/C
7	GND	8	GND



3.18 CompactFlash™ Connector

The 3307700 also offers a Type I/II CompactFlash™ connector which is IDE interface located at the solder side of the board (beneath the SO-DIMM connector). The designated CN17 connector, once soldered with an adapter, can hold CompactFlash™ cards of various sizes. Please turn off the power before inserting the CF card.

- **CN17: CompactFlash™ Connector**

PIN	Description	PIN	Description
1	GND	2	IDE_PDD3
3	IDE_PDD4	4	IDE_PDD5
5	IDE_PDD6	6	IDE_PDD7
7	IDE_PDCS1#	8	GND
9	GND	10	GND
11	GND	12	GND
13	+3.3V	14	GND
15	GND	16	GND
17	GND	18	IDE_PDA2
19	IDE_PDA1	20	IDE_PDA0
21	IDE_PDD0	22	IDE_PDD1
23	IDE_PDD2	24	GND
25	GND	26	GND
27	IDE_PDD11	28	IDE_PDD12
29	IDE_PDD13	30	IDE_PDD14
31	IDE_PDD15	32	IDE_PDCS3#
33	GND	34	IDE_PDIO#

...MORE ON NEXT PAGE...

PIN	Description	PIN	Description
35	IDE_PDIOW#	36	+3.3V
37	INT_IRQ15	38	+3.3V
39	+3.3V	40	N/C
41	RESET#	42	IDE_PDIORDY
43	CF_PDERQ	44	CF_REGB
45	IDE_ACTP#	46	DETECT
47	IDE_PDD8	48	IDE_PDD9
49	IDE_PDD10	50	GND

Inserting a CompactFlash™ card into the adapter is not a difficult task. The socket and card are both keyed and there is only one direction for the card to be completely inserted. Refer to the diagram on the following page for the traditional way of inserting the card.

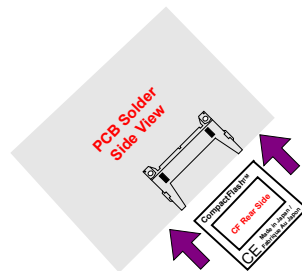

3.19 Mini PCI Slot

3307700 provides a Mini PCI slot. The peripheral component with standard Type III Mini PCI card can be used.

3.20 8-bit I/O Function

The 3307700 offers one 8-bit input/output port by parallel port.

- **JP9: 8-bit Input/Output**

PIN	Description	PIN	Description
1	VCC	2	GND
3	GD0	4	GD4
5	GD1	6	GD5
7	GD2	8	GD6
9	GD3	10	GD7



```

.286

.MODEL SMALL
.DATA
port equ 0378h ;this is data area
;print port can be change to 278h

.CODE

print macro buff
mov dx, offset buff;
mov ah,09h
int 21h
endm

delay :
push cx
mov cx,0155h
@@:
jmp $+2
push cx
mov cx,0ffffh

wait1: loop wait1
pop cx
loop @b
pop cx
ret

begin proc near
mov ax,@data
mov ds,ax

Mov dx, port
Mov al, 80h out dx, al

;;-----
;;ROR
mov cx, 08h
@@:
ror al, 1
call delay
out dx, al
loop @b
pop cx
;;ROL
push cx
mov cx, 08h
@@:
rol al, 1
out dx, al
call delay
loop @b
pop cx
;;-----
;;-----
;;ROR

```

```

mov     cx, 08h
@@:    ror     al, 1
        call delay
        out    dx, al
        loop  @b
        pop   cx
;;ROL
push   cx
mov    cx, 08h
@@:    rol     al, 1
        out    dx, al
        call delay
        loop  @b
        pop   cx
;;-----
;;-----
;;ROR
mov    cx, 08h
@@:    ror     al, 1
        call delay
        out    dx, al
        loop  @b
        pop   cx
;;ROL
push   cx
mov    cx, 08h
@@:    rol     al, 1
        out    dx, al
        call delay
        loop  @b
        pop   cx
;;-----
;;-----
;;ROR
mov    cx, 08h
@@:    ror     al, 1
        call delay
        out    dx, al
        loop  @b
        pop   cx
;;ROL
push   cx
mov    cx, 08h
@@:    rol     al, 1
        out    dx, al
        call delay
        loop  @b
        pop   cx
;;-----
;;-----
;;ROR
mov    cx, 08h

```

```

@@:
    ror    al, 1
    call delay
    out    dx, al
    loop   @b
    pop    cx

;;ROL
    push   cx
    mov    cx, 08h

@@:
    rol    al, 1
    out    dx, al
    call delay
    loop   @b
    pop    cx

;;-----
;;-----
;;ROR
    mov    cx, 08h

@@:
    ror    al, 1
    call delay
    out    dx, al
    loop   @b
    pop    cx

;;ROL
    push   cx
    mov    cx, 08h

@@:
    rol    al, 1
    out    dx, al
    call delay
    loop   @b
    pop    cx

;;-----
;;-----
;;ROR
    mov    cx, 08h

@@:
    ror    al, 1
    call delay
    out    dx, al
    loop   @b
    pop    cx

;;ROL
    push   cx
    mov    cx, 08h

@@:
    rol    al, 1
    out    dx, al
    call delay
    loop   @b
    pop    cx

;;-----

;flash LED 3 time
    mov    cx, 01h

@@:

```

```
        mov     al, 0ffh
        out     dx, al
        call delay
        mov     al, 0h
        out     dx, al
        call delay
        loop    @b
ee:
        mov     ah, 4ch           ;go back to dos
        int     21h
        .stack
        begin   endp
        end begin
```

Any advice or comments about our products and service, or anything we can help you with please don't hesitate to contact with us. We will do our best to support your products, projects and business.



Address: Global American, Inc.
17 Hampshire Drive
Hudson, NH 03051

Telephone: Toll Free U.S. Only (800) 833-8999
(603) 886-3900

FAX: (603) 886-4545

Website: <http://www.globalamericaninc.com>

Support: Technical Support at Global American
