



integration with integrity

User's Manual

Single Board Computer 3303788

Version 1.0, 1999

---

---

## **Copyrights**

This manual is copyrighted and all rights are reserved. It does not allow any non authorization in copied, photocopied, translated or reproduced to any electronic or machine readable form in whole or in part without prior written consent from the manufacturer.

In general, the manufacturer will not be liable for any direct, indirect, special, incidental or consequential damages arising from the use of inability to use the product or documentation, even if advised of the possibility of such damages. The manufacturer keeps the rights in the subject to change the contents of this manual without prior notices in order to improve the function design, performance, quality and reliability. The author assumes no responsibility for any errors or omissions, which may appear in this manual, nor does it make a commitment to update the information contained herein.

## **Trademarks**

Intel is a registered trademark of Intel Corporation.

Award is a registered trademark of Award Software, Inc.

All other trademarks, products and or product's name mentioned herein are mentioned for identification purposes only, and may be trademarks and/or registered trademarks of their respective companies or owners.

---

# Table of Contents

## How to Use This Manual

### Chapter 1. Introduction

1.1 Check List.....	1 – 2
1.2 Product Specifications .....	1 – 3
1.3 System Architecture.....	1 – 6

### Chapter 2. Hardware Configuration Setting

2.1 Jumpers.....	2 – 1
2.2 Connectors.....	2 – 5

### Chapter 3. System Installation

3.1 Socket 370 Celeron Processor .....	3 – 1
3.2 Main Memory .....	3 – 1
3.3 M-system Flash Disk .....	3 – 2
3.4 Installing the Single Board Computer.....	3 – 2
3.4.1 CHIPS 69000 Graphics Controller .....	3 – 3
3.4.2 Intel 82559 Fast Ethernet Controller.....	3 – 5
3.4.3 On-board LED Indicator.....	3 – 6
3.5 Watch Dog Timer Programming.....	3 – 7

## CHAPTER 1

# Introduction

The 3303788 all-in-one full-sized single board computer is designed to fit a high performance Celeron based processor and compatible for high-end computer system application with PCI/ISA bus architecture. It is made to meet today's demanding pace, and keep complete compatibility with hardware and software designed for the IBM PC/AT. The on-board PCI bus supports two PCI devices— VGA and LAN. It's beneficial to build up a high performance and high data availability system for VARs, or system integrators.

This single board computer can run with Intel Pentium-II/III (Celeron or Coppermine) processor, and support DIMM up to 1GB DRAM. The enhanced on-board PCI IDE interface can support 4 drives up to PIO mode 4 timing and Ultra DMA/33 synchronous mode feature. The on-board Super I/O Chipset integrates floppy controller, two serial ports, one FIR (Fast Infrared) port and one parallel port. Two high performance 16C550-compatible UARTs provide 16-byte send/receive FIFOs, and the multi-mode parallel port supports SPP/EPP/ECP function. Besides, two Universal Serial Bus ports provide high-speed data communication between peripherals and PC.

The PICMG standard makes the 3303788 works with the legacy ISA, ISA/PCI or multi-slots PCI-bus backplane. The on-board 32-pin DIP socket supports M-system Disk-On-Chip Flash disk up to 144MB. Built-in Watch-dog Timer function monitors your system status. Two 6-pin Mini-DIN connectors are provided to connect PS/2 mouse and keyboard. The on-board Flash ROM is used to make the BIOS update easier. A standard P8 power connector is reserved to directly get more power for embedded application, and the additional 5-pin shrouded connector is reserved for connecting keyboard interface on the backplane. The high precision Real Time Clock/calendar is built to support Y2K for accurate scheduling and storing configuration information. One 4-pin header is designed to support ATX power function. A feature of CPU overheat protection will give user more security and stability. All of these features make 3303788 excellent in stand-alone applications.

## 1-1 Check List

The 3303788 package includes the following basic items accompany with this manual.

- One 3303788 single board computer
- One Printer port cable kit
- One serial port cable to support two interfaces
- One FDC cable
- One IDE cable
- One 5-pin to 5-pin keyboard cable for backplane connection
- One 4-pin ATX power control cable for backplane connection
- One CD-Title 3303788 to support CHIPS B69000 VGA display driver and Intel 82559 LAN driver

If any of these items is damaged or missed, please contact your vendor and save all packing materials for future replacement and maintenance.

## 1-2 Product Specifications

- **Main processor**  
Intel Celeron processor and Intel Coppermine processor
  - ◇ CPU bus clock : 66/100 MHz
  - ◇ CPU core/bus clock ratio : x2 to x8
- **BIOS**  
AMI system BIOS with 256KB Flash ROM to support DMI, PnP, APM, and ACPI (option)
- **Main Memory**  
Four 168-pin DIMM sockets, supporting 3.3V SDRAM with parity/ECC function up to 1GB
- **L2 Cache Memory**  
128KB L2 cache built in Celeron and 256KB in Coppermine processor
- **Chipset**  
Intel 440BX AGPset
- **Bus Interface**  
Follow PICMG standard (32-bit PCI and 16-bit ISA bus)  
Fully complies with PCI bus specification V2.1
- **PCI IDE Interface**  
Support two enhanced IDE ports up to four HDD devices with PIO mode 4 and Ultra DMA/33 mode 2 timing transfer
- **Floppy Drive Interface**  
Support one FDD port up to two floppy drives and 5-1/4"(360K, 1.2MB), 3-1/2" (720K, 1.2MB, 1.44MB, 2.88MB) diskette format and 3-mode FDD (option)
- **Serial Ports**  
Support two high-speed 16C550 compatible UARTs with 16-byte T/R FIFOs
- **IR Interface**  
Support one 6-pin header for serial Fast/Standard Infrared wireless communication
- **Parallel Port**  
Support SPP, Bi-direction, and EPP/ECP modes

- **USB Interface**  
Support two USB (Universal Serial Bus) ports for high speed I/O peripheral devices
- **PS/2 Mouse and Keyboard Interface**  
Support two 6-pin Mini-DIN connectors and one 5-pin shrouded connector for PS/2 mouse, keyboard and backplane connection
- **ATX Power Control Interface**  
One 4-pin header to support ATX power control with Modem Ring-On and Wake-On-LAN function
- **Auxiliary I/O Interfaces**  
System reset switch, external speaker, Keyboard lock and HDD LED interface
- **Real Time Clock/Calendar**  
Support Y2K Real Time Clock/calendar with battery backup for 10-year data retention
- **Watchdog Timer**  
0.5,1,2,4,8,16,32,64 sec. time-out intervals by jumper setting or 255 intervals from 0.5 min. to 254.5 min. by software programming
- **DiskOnChip Feature**  
Reserved one 32-pin socket for M-systems Flash Disk up to 144MB
- **On-board VGA Interface**  
Adopt CHIPS 69000 HiQVideo Accelerator with integrated memory 2MB to provide high performance graphics and panel display capabilities
- **On-board Ethernet**  
Utilize Intel 82559 Fast Ethernet controller to support RJ-45 interface at 10/100BASE-T speed
- **CPU Overheat Protection**  
Auto speed down when CPU overheats (OS independent & Driverless)
- **System Monitoring Feature**  
Monitor CPU and system temperature, operating voltage, and fan status

- **Power Good**

On-board power good generator with reset time, 300ms ~ 500ms

- **Physical and Environmental Requirements**

- ◆ Outline Dimension (L X W) : 338.5mm (13.36") X 121.5mm (4.78")
- ◆ Board Weight : 0.92 lb. (0.42kg)
- ◆ PCB layout : 6 layer
- ◆ Power Requirements : +5V @6A (typ.), +12V @140mA, -12V @30mA
- ◆ Operating Temperature : 0°C ~ 60°C (32°F ~ 140°F)
- ◆ Storage Temperature : -20°C ~ 80°C
- ◆ Relative Humidity : 5% ~ 95%, non-condensing

## 1-3 System Architecture

The following illustration of block diagram will show you how 3303788 gives you a highly integrated system solution. The most up-to-date system architecture of 3303788, includes two main VLSI chips , 82443BX Host Bridge and 82371EB PIIX4E, to support Celeron processor, SDRAM with ECC, PCI bus interface, ACPI compliant power management (option), USB port, SMBus communication, and Ultra DMA/33 IDE Bus Master. The on-board super I/O chip , W83977ATF, will support PS/2 Keyboard/Mouse, two UARTs, FDC, Parallel and Infrared interface. Besides, an on-board PCI device VGA/panel display will provide user more flexibility and reliability in a highly integrated application.

3303788 built-in Socket 370 to support Intel Celeron processor Plastic Pin Grid Array (**PPGA**) package and Pentium-III FC-PGA Coppermine processor for high performance and cost-effective application. The Intel Celeron processor is the next addition to the P6 micro architecture processor product lines. The Intel Celeron processor, like the Intel Pentium Pro and Intel Pentium II processor, features a Dynamic Execution microarchitecture and also executes MMX technology instructions for enhanced media and communication performance. However, the FC-PGA Coppermine-256 ( Pentium III ) processor provides twice of the Celeron L2 Cache.

The North Bridge 82443BX provides a completely integrated solution for the system controller and data path components in a Celeron processor system. It provides a 64-bit GTL+ based host bus interface, optimized 64-bit DRAM interface with ECC to support two 3.3V DIMMs at the maximum bus frequency of 100 MHz, and 32-bit PCI bus interface to support on-board PCI device.

The South Bridge, 82371EB PCI ISA IDE Xcelerator (PIIX4E), provides a highly integrated multifunction PCI-to-ISA bridge solution for the best industry application. It supports 1-channel dedicated Ultra DMA-33 IDE master interface, full Plug-and-Play compatibility, and Advanced Programmable Interrupt Controller (**APIC**) interface on 3303788. It also supports 2-port Universal Serial Bus (**USB**) and PCI 2.1 Compliance operation. In addition, it also provides XD-bus via buffer logic control to support BIOS read/write access and external Real-time Clock (**RTC**) to maintain date and time of a system.

The Super I/O chip W83977ATF, which integrates two high-speed serial ports, one parallel port, FIR/SIR interface, 8042 keyboard controller with PS/2 mouse ports and FDD interface. This parallel port supports one PC-compatible printer port (**SPP**), Enhanced Parallel Port (**EPP**) and Extended Capabilities Port (**ECP**).

In 3303788, it contains Watch-dog Timer (**WDT**) enabled by jumper setting and triggered by software, and DiskOnChip (**DOC**) for M-systems Flash disk. Besides, an advanced feature is used on 3303788 to support detection of CPU temperature. The CPU operation will be automatically forced to speed down when overheating happens.

The on-board PCI device, graphics display port, powered by CHIPS 69000 graphics accelerator to support one VGA display and panel interface port. Another on-board PCI device, LAN port, powered by Intel 82559 10/100 Ethernet Controller supports Fast Ethernet interface through RJ-45 port.

All of detail operating relations are shown in Figure 1-1 3303788 System Block Diagram.

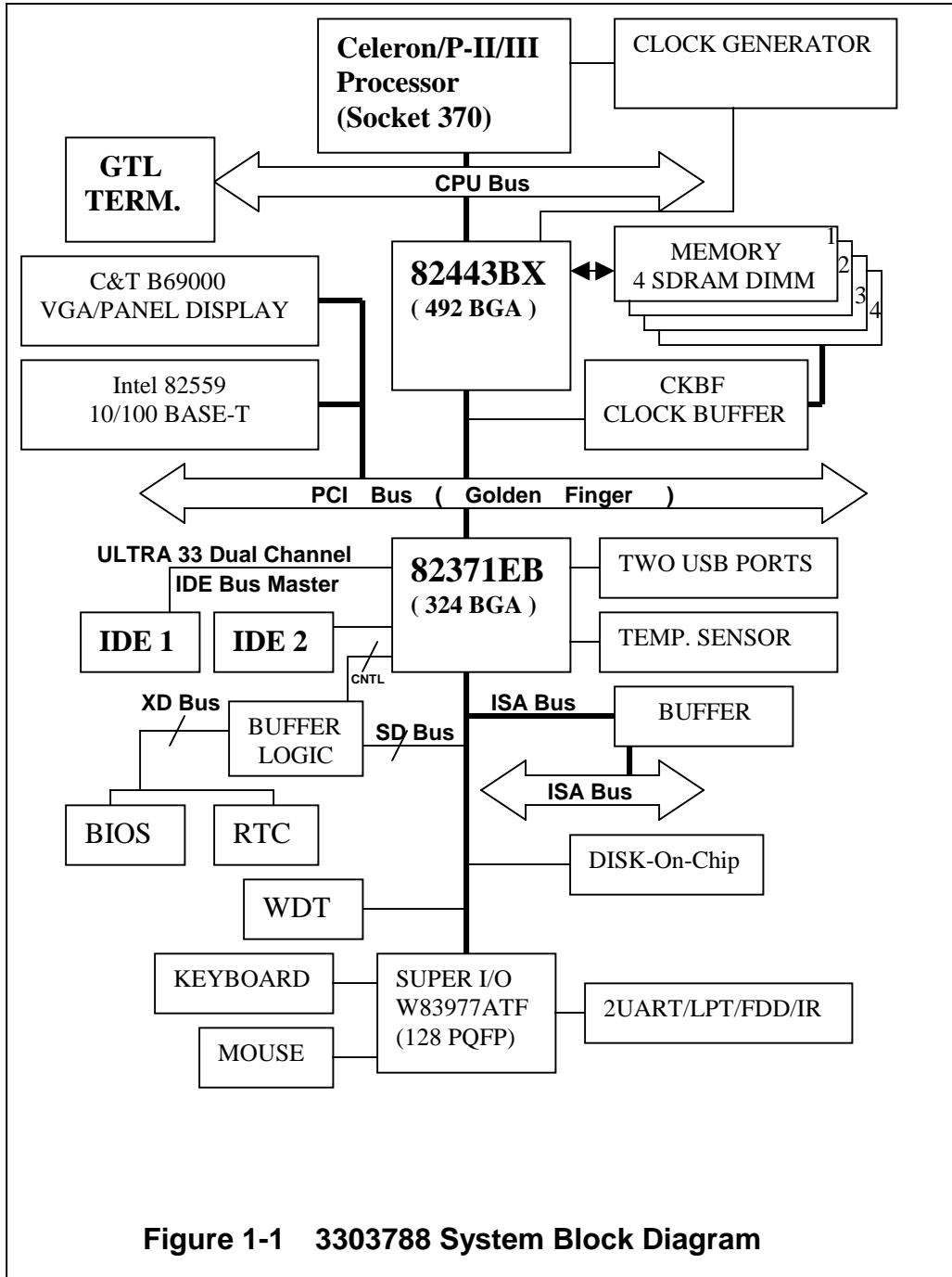

CHAPTER 2

**Hardware Configuration Setting**

This chapter gives the definitions and shows the positions of jumpers, headers and connectors. All of the configuration jumpers on 3303788 are in the proper position. The default settings set by factory are marked with a star (★).

**2-1 Jumpers**

In general, jumpers on the single board computer are used to select options for certain features. Some of the jumpers are designed to be user-configurable, allowing for system enhancement. The others are for testing purpose only and should not be altered. To select any option, cover the jumper cap over (close) or remove (open) it from the jumper pins according to the following instructions. (Refer to Figure 2-1 for jumper positions)

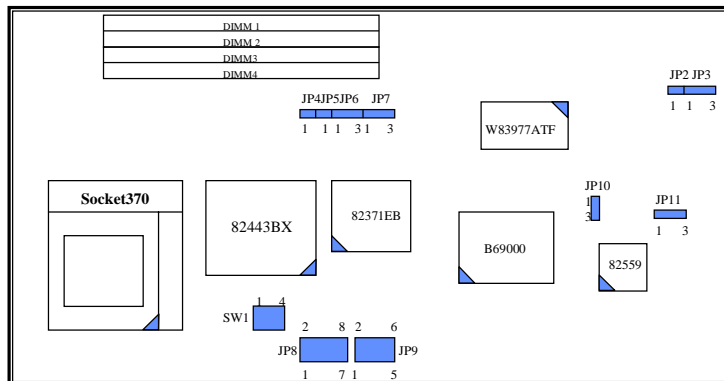

Figure 2-1 3303788 Jumper Locations

**CPU Jumper Setting Table (SW1)**

SW1 DIP switch settings for CPU core/bus ratio

SW-1	SW-2	SW-3	SW-4	CORE/BUS RATIO
OFF	OFF	ON	OFF	1.5x
OFF	OFF	OFF	OFF	2.0x
ON	ON	ON	ON	2.0x
ON	OFF	ON	ON	2.5x
ON	ON	OFF	ON	3.0x
ON	OFF	OFF	ON	3.5x
ON	ON	ON	OFF	4.0x
ON	OFF	ON	OFF	4.5x
ON	ON	OFF	OFF	5.0x
ON	OFF	OFF	OFF	5.5x ★
OFF	ON	ON	ON	6.0x
OFF	OFF	ON	ON	6.5x
OFF	ON	OFF	ON	7.0x
OFF	OFF	OFF	ON	7.5x
OFF	ON	ON	OFF	8.0x
OFF	ON	OFF	OFF	Reserved

**NOTE :** For system stability, do not arbitrarily set CPU to run over speed unless you can handle BIOS parameters.

**Disk-On-Chip Jumper Setting (JP8)**

1 – 2	3 – 4	5 – 6	7 – 8	Memory Address Window
Short	NC	NC	NC	D0000 – D1FFF ★
NC	Short	NC	NC	D2000 – D3FFF
NC	NC	Short	NC	D4000 – D5FFF
NC	NC	NC	Short	D6000 – D7FFF

**Watch-Dog Timer Jumper Setting (JP4, JP5, JP6, JP7, JP9)**

**JP4** NC : Enabled WDT function  
Short : Disabled WDT function ★

**JP5** NC : Allocate I/O port 0533H/0033H for programming of H/W WDT ★  
Short : Allocate I/O port 0543H/0343H for programming of H/W WDT

- JP6** 1 – 2 : Connect WDT output to system reset ★  
 2 – 3 : Connect WDT output to NMI

**JP9** WDT Time-out Interval (Twd) settings

5-6	3-4	1-2	Time-out Interval (Twd)
Short	Short	Short	0.5 sec.
Short	Short	NC	1 sec. ★
Short	NC	Short	2 sec.
Short	NC	NC	4 sec.
NC	Short	Short	8 sec.
NC	Short	NC	16 sec.
NC	NC	Short	32 sec.
NC	NC	NC	64 sec.

**JP7** WDT Time-out sources :

- 1 – 2 : initiated from hardware WDT by setting JP9 ★  
 2 – 3 : initiated from software WDT by programming super I/O chipset  
 W83977ATF

**RTC CMOS Clear Jumper Setting (JP2)**

- JP2** NC : Normal operation ★  
 Short : Clear CMOS contents

**NOTE :** This CMOS clearing operation can be done under system power on if CMOS RAM CLEAR FUNCTION does not exist in Advanced Chipset Setup. It also can be done under system power on or off. However please make sure that the CMOS RAM clear option has been enabled in Advanced Chipset Setup before CMOS clearing happens.

**AT/ATX Power Supply Selection (JP3)**

- JP3** 1 – 2 : Select ATX power supply  
 2 – 3 : Select AT power supply ★

**Onboard devices (VGA/Ethernet) enable/disable jumper (JP10/JP11)**

**JP10** 1 – 2 : Normal operation ★  
2 – 3 : Disable onboard VGA

**JP11** 1 – 2 : Normal operation ★  
2 – 3 : Disable onboard Ethernet

## 2-2 Connectors

I/O peripheral devices and Flash disk will be connected to these interface connectors or DOC socket located on this single board computer.

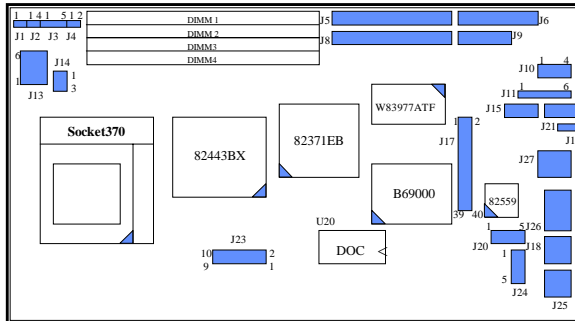

Figure 2-2 3303788 Connector Locations

CONNECTOR	FUNCTION	REMARK
J1	System reset	
J2	External speaker interface	
J3	Keyboard lock and power indicator	
J4	IDE active LED interface	
J5	IDE1 (Primary) interface	
J6	Floppy connector	
J8	IDE2 (Secondary) interface	
J9	Parallel port connector	
J10	ATX power control interface	Connect to Backplane
J11	IrDA (infrared) port	Support FIR/SIR
J12	ATX power button interface	Connect to Chassis
J13	Standard P8 power connector	
J14	CPU cooling fan power connector	Support +12V
J15	COM1 serial port	2 x 5 shrouded
J17	Flat Panel display module interface	2x20 pin header
J18	PS/2 mouse connector	6-pin Mini-DIN
J20	External PS/2 mouse connector	Connect mouse cable kit
J21	COM2 serial port	2 x 5 shrouded
J23	External USB interface	Support two ports
J24	External keyboard interface	Connect to backplane
J25	PS/2 keyboard connector	6-pin Mini-DIN
J26	VGA connector	DSUB-15
J27	Ethernet connector	RJ-45
U20	On-board Flash disk (DiskOnChip)	32-pin DIP socket

## **Pin Assignments of Connectors**

### ■ J1 : Reset Header

<b>PIN No.</b>	<b>Signal Description</b>
1	Reset
2	Ground

### ■ J2 : External Speaker Header

<b>PIN No.</b>	<b>Signal Description</b>
1	Speaker signal
2	N/C
3	Ground
4	+5V

### ■ J3 : Keyboard Lock Header

<b>PIN No.</b>	<b>Signal Description</b>
1	+5V (330 ohm pull-up for power LED)
2	N/C
3	Ground
4	Keyboard inhibit
5	Ground

### ■ J4 : IDE1 Active LED Header

<b>PIN No.</b>	<b>Signal Description</b>
1	+5V (470 ohm pull-up for HDD LED)
2	HDD Active # (LED cathode terminal)

### ■ J10 : ATX Power Control Connector

<b>PIN No.</b>	<b>Signal Description</b>
1	ATX Power Good Signal
2	ATX 5V Stand-by
3	ATX Power On Control
4	Ground

### ■ J5/ J8 : IDE1/IDE2 Interface Connector

PIN No.	Signal Description	PIN No.	Signal Description
1	RESET#	2	Ground
3	Data 7	4	Data 8
5	Data 6	6	Data 9
7	Data 5	8	Data 10
9	Data 4	10	Data 11
11	Data 3	12	Data 12
13	Data 2	14	Data 13
15	Data 1	16	Data 14
17	Data 0	18	Data 15
19	Ground	20	N/C
21	DMA REQ	22	Ground
23	IOW#	24	Ground
25	IOR#	26	Ground
27	IOCHRDY	28	Pull-down
29	DMA ACK#	30	Ground
31	INT REQ	32	N/C
33	SA1	34	N/C
35	SA0	36	SA2
37	HDC CS0#	38	HDC CS1#
39	HDD Active#	40	Ground

### ■ J11 : Fast & Standard IrDA Header

PIN No.	Signal Description
1	VCC (+5V)
2	FIRRX
3	SIRRX
4	Ground
5	IRTX
6	N/C

### ■ J14 : CPU Cooling FAN Power Connector

PIN No.	Signal Description
1	Ground
2	+12V
3	Pull-up +5V (Reserved for fan sense)

■ **J6 : FDC Interface Connector**

PIN No.	Signal Description	PIN No.	Signal Description
1	Ground	2	Density Select
3	Ground	4	N/C
5	Ground	6	N/C
7	Ground	8	Index#
9	Ground	10	Motor ENA#
11	Ground	12	Drive Select B#
13	Ground	14	Drive Select A#
15	Ground	16	Motor ENB#
17	Ground	18	Direction#
19	Ground	20	Step#
21	Ground	22	Write Data#
23	Ground	24	Write Gate#
25	Ground	26	Track 0#
27	Ground	28	Write Protect#
29	Ground	30	Read Data#
31	Ground	32	Head Select#
33	Ground	34	Disk Change#

■ **J9 : Parallel Port Connector**

PIN No.	Signal Description	PIN No.	Signal Description
1	Strobe#	14	Auto Form Feed#
2	Data 0	15	Error#
3	Data 1	16	Initialization#
4	Data 2	17	Printer Select IN#
5	Data 3	18	Ground
6	Data 4	19	Ground
7	Data 5	20	Ground
8	Data 6	21	Ground
9	Data 7	22	Ground
10	Acknowledge#	23	Ground
11	Busy	24	Ground
12	Paper Empty	25	Ground
13	Printer Select	26	N/C

■ **J13 : Standard P8 Power Connector**

PIN No.	Signal Description
1	N/C
2	+5V
3	+12V
4	-12V
5	Ground
6	Ground

■ **J18 : PS/2 Mouse Connector (6-pin Mini-DIN)**

PIN No.	Signal Description
1	Mouse Data
2	N/C
3	Ground
4	+5V
5	Mouse Clock
6	N/C

■ **J20 : External PS/2 Mouse Connector**

PIN No.	Signal Description
1	Mouse Clock
2	Mouse Data
3	N/C
4	Ground
5	+5V

■ **J23 : External USB Interface Connector**

PIN No.	Signal Description	PIN No.	Signal Description
1	+5V	2	N/C
3	SBD0- (USBP0-)	4	Ground
5	SBD0+ (USBP0+)	6	SBD1+ (USBP1+)
7	Ground	8	SBD1- (USBP1-)
9	N/C	10	+5V

■ **J12 : ATX Power Button Interface**

PIN No.	Signal Description
1	Power Button Control Signal
2	Ground

**■ J17 : Flat Panel Display Module Interface**

<b>PIN No.</b>	<b>Signal Description</b>	<b>PIN No.</b>	<b>Signal Description</b>
1	P0	2	P1
3	P2	4	P3
5	P4	6	P5
7	P6	8	P7
9	P8	10	P9
11	P10	12	P11
13	P12	14	P13
15	P14	16	P15
17	Ground	18	P16
19	SHFCLK	20	P17
21	Ground	22	Ground
23	P18	24	P19
25	P20	26	P21
27	P22	28	P23
29	FLM	30	ENAVEE
31	LP	32	PCLK
33	M	34	+5V
35	+12V	36	+5V
37	+12V	38	+5V
39	Ground	40	Ground

**■ J24 : External Keyboard Connector**

<b>PIN No.</b>	<b>Signal Description</b>
1	Keyboard Clock
2	Keyboard Data
3	N/C
4	Ground
5	+5V

**■ J25 : PS/2 Keyboard Connector (6-pin Mini-DIN)**

<b>PIN No.</b>	<b>Signal Description</b>
1	Keyboard Data
2	N/C
3	GND
4	+5V
5	Keyboard Clock
6	N/C

**■ J27: Ethernet RJ-45 Interface Connector**

PIN No.	Signal Description
1	TX+
2	TX-
3	RX+
4	Termination to Ground
5	Termination to Ground
6	RX-
7	Termination to Ground
8	Termination to Ground

**■ J15/J21 : Serial Port 2x5 Shrouded Connector**

PIN	Signal Description	PIN	Signal Description
1	Data Carrier Detect (DCD)	6	Data Set Ready (DSR)
2	Receive Data (RXD)	7	Request to Send (RTS)
3	Transmit Data (TXD)	8	Clear to Send (CTS)
4	Data Terminal Ready (DTR)	9	Ring Indicator (RI)
5	Ground (GND)	10	N/C

**■ J26 : VGA DSUB-15 Connector**

PIN No.	Signal Description
1	R
2	G
3	B
4	N/C
5	Ground
6	Ground
7	Ground
8	Ground
9	N/C
10	Ground
11	N/C
12	MONID1
13	HSYNC
14	VSYNC
15	MONID2



## CHAPTER 3

# System Installation

This chapter provides you with instructions on how to set up your system. The additional information shows you how to install M-systems Flash disk, set up LCD display and handle WDT operation in software program.

### 3-1 Socket 370 Celeron/Pentium III Processor

#### Installing CPU

- 1) Lift the handling lever of CPU socket outwards and upwards to the other end.
- 2) Align the processor pins with pin holes on the socket. Make sure that the notched corner or dot mark (pin 1) of the CPU corresponds to the socket's bevel end. Then press the CPU gently until it fits into place. If this operation is not easy or smooth, don't do it forcibly. You need to check and rebuild the CPU pin uniformly.
- 3) Push down the lever to lock processor chip into the socket.
- 4) Follow the installation guide of cooling fan or heat sink to mount it on CPU surface and lock it on the socket 370.
- 5) Be sure to follow particular CPU speed and voltage type to adjust the jumper settings properly.

#### Removing CPU

- 1) Unlock the cooling fan first.
- 2) Lift the lever of CPU socket outwards and upwards to the other end.
- 3) Carefully lift up the existing CPU to remove it from the socket.
- 4) Follow the steps of installing a CPU to change to another one or place handling bar to close the opened socket.

### 3-2 Main Memory

This 3303788 provides four 168-pin Dual In-line Memory Modules (**DIMM**) to support on-board main memory. The maximum memory size for 3.3V EDO DRAM or SDRAM is 1GB. Normally, the DIMM used could be either 3.3V EDO (Extended Data Out) memory with speed less than 70ns or 3.3V SDRAM (Synchronized DRAM) with speed less than 100ns (-10). If you adopt 100MHz system clock, you need to use SDRAM with speed less than 80ns (-8). It is better to use PC100-compliant memory chip on your system.

For system compatibility and stability, don't use memory module without brand. You can also use the single or double-side DIMM without parity check and ECC function.

Watch out the contact and lock integrity of memory module with socket, it will impact on the system reliability. Follow normal procedure to install your DRAM module into memory socket. Before locking, make sure that the module has been fully inserted into card slot.

**NOTE : For maintaining system stability, don't change any of DRAM parameters in BIOS setup to upgrade your system performance except for getting technical information.**

### 3-3 M-systems Flash Disk

3303788 reserves one 32-pin DIP sockets for installing M-systems Flash disk from 2MB to 144MB. This operation structure is running with pure ISA-bus without PnP (Plug and Play) function. Before installing, make certain that I/O address jumper setting is set on right position to prevent unworkable system due to I/O resource conflict. Do remember to follow DOC (DiskOnChip) installation procedure. Otherwise, the Flash chip is possible to be burned out due to incorrect installation.

#### **Installing DOC**

Align the DOC with pin holes on the socket. Make sure that the notched corner or dot mark (pin 1) of DOC corresponds to notched corner of the socket. Then press the DOC gently until it fits into place. If installation procedure is correct, the Flash disk can be viewed as a normal hard disk to access read/write data.

**WARNING : Please ensure that your DOC is properly inserted. Placing the DOC in reverse will cause severe damage to it.**

If you want to boot from this Flash disk, it is necessary to refer to the application note from M-systems. You can easily obtain relative information from M-systems shipping package (such as product manual) or Web-site <http://www.m-sys.com>.

## 3-4 Installing the Single Board Computer

To install your 3303788 into standard chassis or proprietary environment, you need to perform the following :

- ❑ Step 1 : Check all jumpers setting on proper position
- ❑ Step 2 : Install and configure CPU and memory module on right position
- ❑ Step 3 : Place 3303788 into the dedicated position in your system
- ❑ Step 4 : Attach cables to existing peripheral devices and secure it

**NOTE : Please refer section 3-4-1 to 3-4-5 to install display driver and setup your system.**

### 3-4-1 CHIPS 69000 Graphics Controller

The following table will show you how to enable and disable on-board C&T 69000 VGA function by putting jumpers at proper position.

JP10	FUNCTION
1-2	Enable on-board VGA
2-3	Disable on-board VGA

The on-board graphics controller adopts CHIPS 69000 that integrates high performance memory technology for the graphics frame buffer. Based on the proven HiQVideo graphics accelerator core, the 69000 combines state-of-the-art flat panel controller capabilities with low power, high performance integrated memory. It incorporates 2MB of proprietary integrated SDRAM for the graphics/video frame buffer. The integrated SDRAM memory can support up to 83MHz operation, thus increasing the available memory bandwidth for the graphics subsystem to support high color/high resolution application.

The 69000 supports a wide variety of monochrome and color Single-Panel, Single-Drive and Dual-Panel, Dual Drive, standard and high-resolution, passive STN and active matrix TFT/MIM LCD, and EL panels. It is designed to support high performance graphics and video acceleration for all supported display resolutions, display types, and color modes. This PCI device 69000 can be configured to operate an analog CRT monitor and flat panel at the same time.

### **Display Modes Supported**

The 69000 supports the modes which appear in the table below.

<b>Resolution</b>	<b>Color (bpp)</b>	<b>Refresh Rates (Hz)</b>
640x480	8	60, 75, 85
640x480	16	60, 75, 85
640x480	24	60, 75, 85
800x600	8	60, 75, 85
800x600	16	60, 75, 85
800x600	24	60, 75, 85
1024x768	8	60, 75, 85
1024x768	16	60, 75, 85
1280x1024	8	60

---

### 3-4-2 Intel 82559 Fast Ethernet Controller

The following table will show you how to enable and disable on-board Intel 82559 LAN function by putting jumpers at proper position.

<b>JP11</b>	<b>FUNCTION</b>
1-2	Enable on-board LAN
2-3	Disable on-board LAN

#### **Drivers Support**

Please find 82559 LAN driver in Ethernet directory of 33037888 CD-title.

### 3-4-3 On-board LED Indicator

The 3303788 provides three LED indicators to show LAN interface status. These messages will give you a guide for troubleshooting.

LED1 (top) (LAN speed LED)

ON : indicates 100Mbps activity

OFF : indicates 10Mbps activity

LED2 (center) (LAN active LED)

ON : indicates Tx/Rx activity

OFF : no activity

LED3 (bottom) (LAN Link Integrity LED)

ON : indicates link is good in either 10 or 100 Mbps

OFF : link is bad

### 3-5 Watch Dog Timer Programming

There are two manners to activate the Watch-Dog Timer (WDT) function. One is to utilize hardware jumper setting and programmed by software command. After this feature is enabled, a system reset will be generated unless a application triggers the timer periodically within time-out period. This allows the system to restart in an orderly way in case of any abnormal condition is found. Another one is to program super I/O W83977ATF chip to start WDT time-out counting. It is recommended to use first approach. The second choice is comparatively difficult and complicated. In addition, you can also connect WDT output to NMI input by setting JP6 jumper to generate NMI event to support special interrupt service routine.

An optional two-port WDT is provided on 3303788. This WDT comes with 8 possible ranges of time intervals from 500 ms to 64 sec., which can be adjusted by setting jumper positions. It could be enabled and programmed by reading I/O port 0533H or 0543H to issue trigger continuously, and disabled by reading I/O port 0033H or 0343H. A tolerance of 30% timer limit must be considered. For instance, if the time-out interval is set to 1second, the WDT trigger command must be issued within 700ms at least.

The below example gives you a reference algorithm for WDT programming via I/O port 0533H and 0033H in your application program :

**Enable WDT**

```
MOV    DX, 0533H
IN     AL, DX
```

**Re-trigger WDT**

```
MOV    DX, 0533H
IN     AL, DX
```

**Disable WDT**

```
MOV    DX, 0033H
IN     AL, DX
```

**NOTE : Please directly contact your technical specialist to get WDT programming information on super I/O chip W83977ATF for long time-out interval support from 0.5 minutes to 254.5 minutes.**

---

Any advice or comments about our products and service, or anything we can help you with please don't hesitate to contact with us. We will do our best to support your products, projects and business.



Address: Global American, Inc.  
17 Hampshire Drive  
Hudson, NH 03051

Telephone: Toll Free (U.S. Only) 800-833-8999  
(603)886-3900

FAX: (603)886-4545

Website: <http://www.globalamericaninc.com>

E-Mail: [salesinfo@globalamericaninc.com](mailto:salesinfo@globalamericaninc.com)

---