



User's Manual

3301180

Table of Contents

Introduction	4
Specifications	5
Board Image	7
Board Layout	9
Jumper/Connector Quick Reference	10
Jumper/Connector Quick Reference	11
CMOS Jumper Settings.....	12
DOC Address Select	13
Serial Port Selection (RS232C/422/485).....	14
LCD Voltage Select	15
Watchdog Timer	16
Fast Ethernet Connectors	19
Power Connector	20
Switches and Indicators	21
Interface Connectors HDD, FDD	23
Peripheral Port	25
Compact Flash Disk	30

System Resources	32
Flat Panel VGA	34
Flat Panel VGA	35
Flat Panel VGA	36
AWARD BIOS Setup	37
Setup Items	37
Standard CMOS Setup	39
BIOS Features Setup	41
Chipset Features Setup	44
Power Management Setup	46
PnP/PCI Configuration	47
Integrated Peripherals	48
POST Codes	50
Howto : Flash the BIOS	57
Warranty	59

Introduction

Global American's product of 3301180 is a 3.5" SBC with an on-board embedded 5x86 class CPU , NS Geode GX1-300 processor. With this board, system engineers will be able to upgrade 386-based or 486-based to 586-level without some additional worries, because a NS Geode GX1-300 processor and 64MB SDRAM are mounted on 3301180 . No longer worry about the CPU installation , don't need to set any jumpers of speed or voltage of processor . And the fan is not necessary for NS Geode Gx1-300 , the MTBF worries will be reduced . DRAM on-board will improve the ability of the anti-vibration . 3301180 has the good reliability for system designer .

With its ultra low power, rich levels of integration, advanced multimedia capabilities and communication features, this board is an exciting opportunity for System Integrators and OEMs to develop new generation products that meet the desires and aspirations of the 21th century consumers.

Specifications

General Specifications

- **CPU** : NS Geode GX1 300MHz MHz with FSB 33MHz.
- **Chipset** : NS CS5530A.
- **BIOS** : AWARD® Flash BIOS
- **Green Function** : power saving supported in BIOS. DOZE / STANDBY APM
- **L1 Cache** : Integrated on CPU
- **L2 Cache** : Integrated on CPU
- **DRAM Memory** : Onboard 64MB SDRAM, and up to 256MB of SDRAM on SODIMM (Total of 320MB Memory)
- **Enhanced IDE with UltraDMA** : supports 2 port and up to 4 ATAPI devices, Ultra DMA transfer 33 MB/sec. Two 44-pin (2.0 pitch) box header.
- **Watchdog Timer** : 1~127 Sec generates RESET when your application loses control over the system.
- **Real-time Clock** : built-in chipset with lithium battery backup. CMOS data backup of BIOS setup and BIOS default.

High Speed Multi I/O

- **Chipset** : Winbond 83977F
- **Serial Ports** : Two high speed RS-232C ports (COM1). One high speed RS-232C/422/485 port COM2 (jumper selectable). Both with 16C550 compatible UART.
- **USB** : 2 onboard USB ports Ver 1.1.
- **SIR Interface** : onboard IrDA TX/RX port
- **Floppy Disk Drive Interface** : 2 floppy disk drives, 3? (720 KB, 1.44 MB or 2.88 MB).
- **Bi-directional Parallel Port** : SPP, EPP and ECP mode.
- **Keyboard and Mouse Connectors** : external PS/2 KB/Mouse port (2-in-1 mini DIN) and onboard AT Keyboard port (6-pin box header)
- **Audio Chipset**: NS CS5530A, AC97 2.0 compliant, Multistream Direct Sound and Direct Sound 3D acceleration. (Line-in, CD Audio in, MIC in, Speaker out)

Network Interface Controller

- **Chipset** : Single Realtek 8139C, 10/100 Mbps
- **Connector** : external RJ-45 with LEDs on connector

Display Controller

- **Chipset** : C&T69000 (3301180A), CS5530A (3301180B)
- **Display Type** : CRT (VGA, SVGA, XGA, SXGA), 24-bit (C&T69000) and 16-bit (CS5530A) TFT LCD TV-Out (3301180B including)
- **Connectors** : external DB15 for CRT on-board
- **Resolution**: >3301180A CRT resolutions up to 1280x1024 @ 256 colors or 1204x768 @ 16bit or 800x600 @ 24bit . Panel resolutions up to 1280x1024 @ 8bpp or 1024x768 @ 16bpp or 800x600 @ 24bpp.

>3301180B CRT resolutions up to 1280x1024 @ 256 colors or 1024x768 @ 16bit . Panel resolutions up to 1280x1024 @ 8bpp or 1024x768 @ 16bpp .

SSD Interfaces

- **DiskOnChip (DOC)**
 - **Package** : Single Chip Flash Disk in 32-pin DIP JEDEC
 - **Capacity** : Up to 288 MByte
 - **Data Reliability** : ECC/EDC error correction
 - **Memory Window** : 8 KByte
- **Compact Flash Card (CFC)**
 - **Compact Flash Socket** : supports Type I/II CFC
 - **Capacity** : up to 512MB CFC

Environmental and Power

- **Power Requirements** : +5 V @ 1.32 A (typical);(Low Power Embedded NS Geode GX1 300MHz with onboard 64 SDRAM)
- **Board Dimensions** : 145mm x 102mm
- **Board Weight** : 0.176kg
- **Operating Temperature** : 0 to 60°C (32 to 140°F)
- **Operating Humidity** : 0%~90%

Board Image

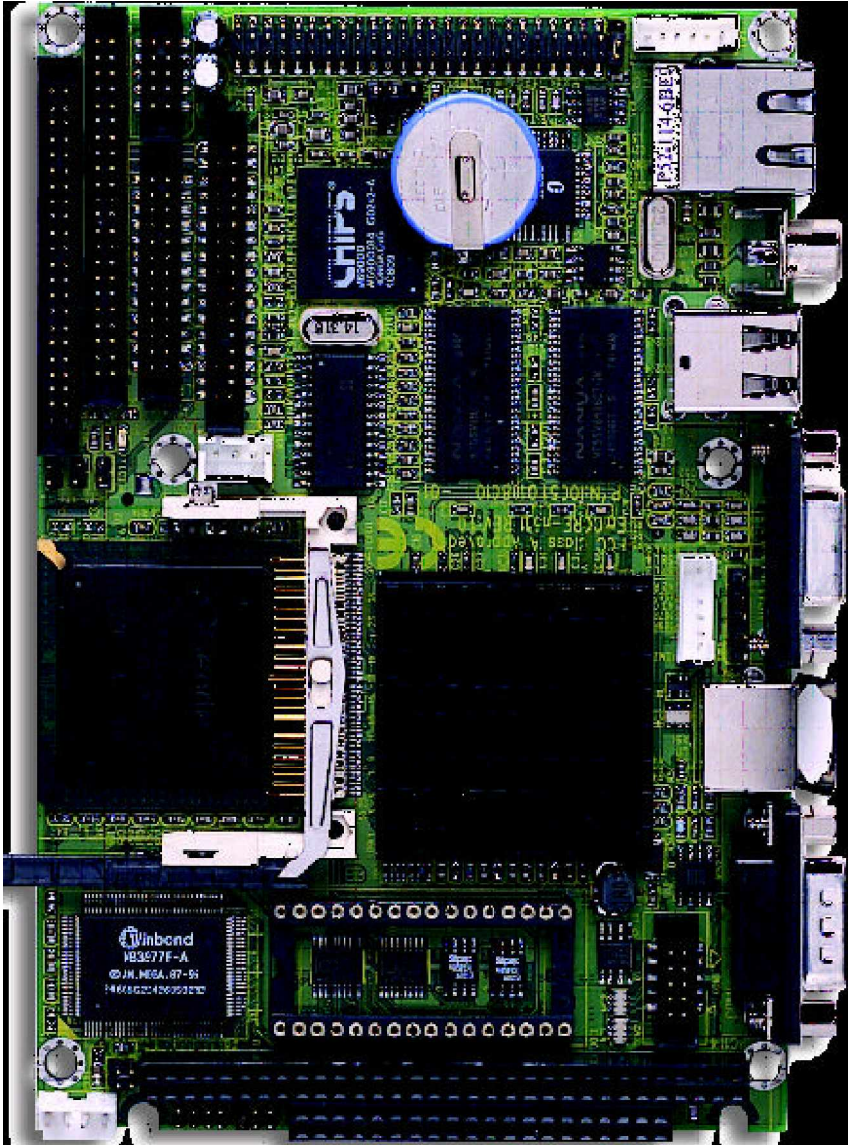

Warning

Single Board Computers and their components contain very delicate Integrated Circuits (IC). To protect the Single Board Computer and its components against damage from static electricity, you should always follow the following precautions when handling it :

1. Disconnect your Single Board Computer from the power source when you want to work on the inside
2. Hold the board by the edges and try not to touch the IC chips, leads or circuitry
3. Use a grounded wrist strap when handling computer components.
4. Place components on a grounded antistatic pad or on the bag that came with the Single Board Computer, whenever components are separated from the system

Ordering Codes

3301180A

3.5" NS GX1 Module with 64MB on-board and one SODIMM up to 320 MB SDRAM , C&T 69000 Flat Panel / CRT VGA , Fast Ethernet , Audio

3301180B

3.5" NS GX1 Module with 64MB on-board and one SODIMM up to 320 MB SDRAM , Flat Panel / CRT VGA , TV-out, Fast Ethernet , Audio

Note : Cable Kit is optional.

Board Layout

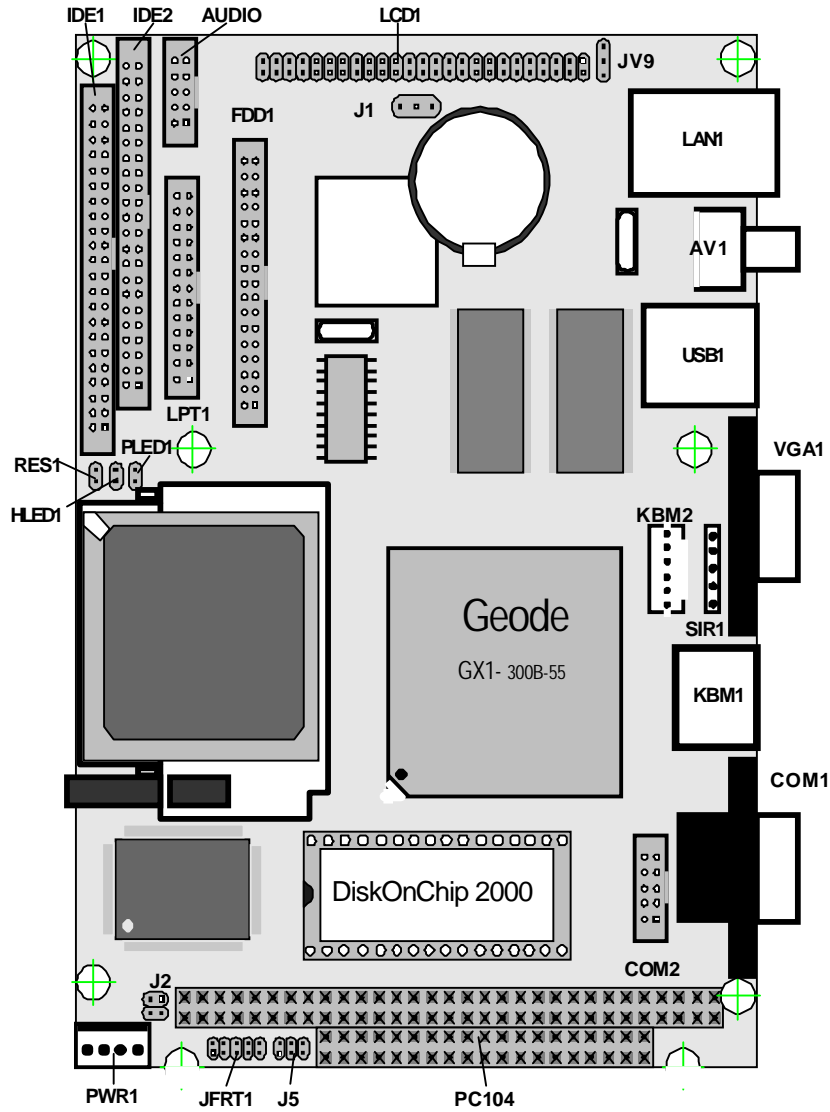

Jumper/Connector Quick Reference

Jumpers

Label	Function
J1	Clear CMOS
J2	DOC Address Select
J5	COM2 RS-232C / 422 / 485 Selection
JV9	LCD Voltage Select

Jumper/Connector Quick Reference

Connectors

Label	Function
VGA1	VGA Display Connector
LCD1	LCD Connector
IDE1	Primary IDE Connector
IDE2	Secondary IDE Connector
CFD	Compact Flash Connector
USB1	USB Port 0,1
AUDIO	Audio Interface Port
SIR1	Infrared (IR) Connector
KBM1	Keyboard and PS/2 Mouse (Mini Din)
KBM2	Keyboard and PS/2 Mouse
FDD1	Floppy Drive Connector
LAN1	10/100M LAN1 Connector
LPT1	Parallel Port
COM1	RS-232C Serial Port (DSub-9)
COM2	RS-232C/422/485 Serial Port
PWR1	Small 4P Power Connector
DOC 2000	Disk On Chip 2000
RES1	Reset Switch
PC104	ISA PC-104 Interface
PLED1	Power LED
HLED1	HDD LED
JFRT1	Front Panel Connector
AV1	Vedio Out
SODIM1	SODIMM Socket

CMOS Jumper Settings

CMOS Operation (J1)

Type : J1: onboard 3-pin header

If the 3301180 refuses to boot due to inappropriate CMOS settings here is how to proceed to clear (reset) the CMOS to its default values.

CMOS Setup (J1)	J1	Status
Normal Operation	1-2	ON
Clear CMOS	2-3	ON
default setting	1-2	ON

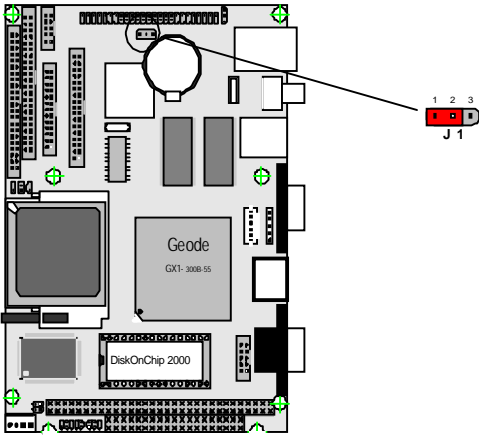

DOC Address Select

DOC Address Select (J2)

Type : J2: onboard 4-pin(2*2) header

Port Address	1-2	3-4
D800h	OFF	OFF
D000h	ON	OFF
Disable	ON	ON

default setting D800h

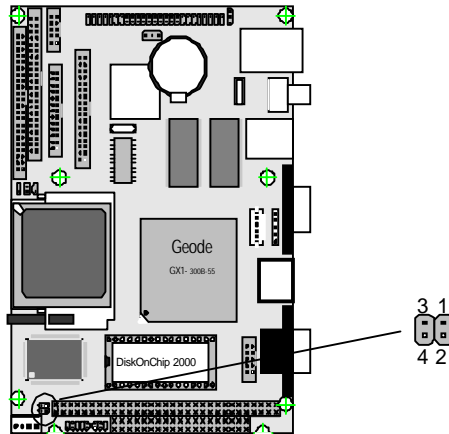

Serial Port Selection (RS232C/422/485)

RS-232C/422/485 Mode select (J5)

Type : J5: onboard 6-pin(2*3) header

RS-422/485 Mode on COM2

The onboard COM2 port can be configured to operate in RS-422 or RS-485 modes. RS-422 modes differ in the way RX/TX is being handled. Jumper J5 switches between RS-232C or RS-422/485 mode. All of the RS-232C/422/485 modes are available on COM2.

COM2			
Pin Defined:	RS-232C	RS-422	RS-485
Pin1 :	DCD	Tx+	RTx+
Pin2 :	RXD	Tx-	RTx-
Pin8 :	CTS	Rx+	x
Pin9 :	RI	Rx-	x

J5 Selection	1-2	3-4	5-6
RS-232C	ON	OFF	OFF
RS-422	OFF	ON	OFF
RS-485	OFF	OFF	ON

default setting RS-232C

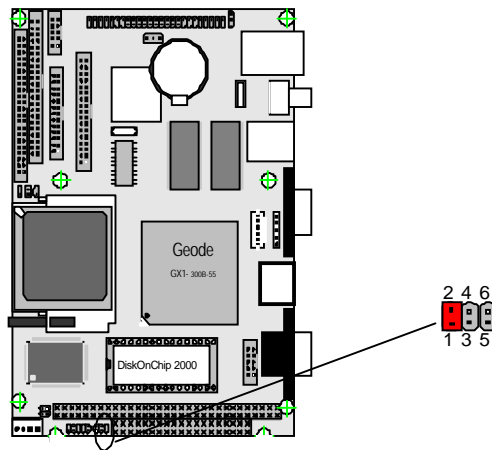

LCD Voltage Select

LCD Voltage Select : JV9

Type : JV9: onboard 3-pin header

The voltage of LCD panel could be selected by JV9 in 5V or 3.3V .

Mode	JV9
5V	1-2
3.3V	2-3
default setting	3.3V

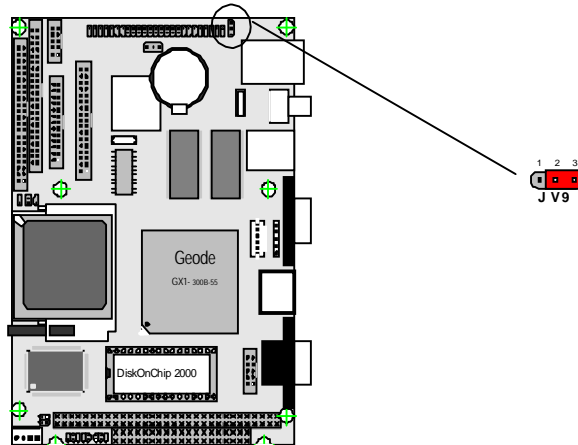

Watchdog Timer

Watchdog Output

The onboard watchdog timer can be disabled by jumper setting or enabled for either reboot by system RESET. The Jumper is on the carrier board.

Even if enabled by jumper setting upon boot the watchdog timer is always inactive. To initialize or refresh the watchdog timer writing of port 444H is sufficient. To disable the watchdog timer read port 44H.

Status	Action
Enable/refresh the Watchdog Timer	I/O Write 444H
Disable the Watchdog Timer.	I/O Read 044H

After the watchdog timer has been initialized by reading port 444H, it has to be strobed at preconfigured intervals to keep it from issuing a RESET or NMI.

The watchdog timer timeout intervals are set by software programming.

Timeout Values

Timeout values are programmed. The watchdog timer supports 128 steps. Use the table on the next page to find the hexadecimal value that needs to be passed on to get the correct timer interval. Look subsequently at the program example how to pass the value to the watchdog timer.

Timeout Table

Level	Value	Seconds	Level	Value	Seconds	Level	Value	Seconds
1	1	1	2	2	2	3	3	3
4	4	4	5	5	5	6	6	6
7	7	7	8	8	8	9	9	9
10	A	10	11	B	11	12	C	12
13	D	13	14	E	14	15	F	15
16	10	16	17	11	17	18	12	18
19	13	19	20	14	20	21	15	21

22	16	22	23	17	23	24	18	24
25	19	25	26	1A	26	27	1B	27
28	1C	28	29	1D	29	30	1E	30
31	1F	31	32	20	32	33	21	33
34	22	34	35	23	35	36	24	36
37	25	37	38	26	38	39	27	39
40	28	40	41	29	41	42	2A	42
43	2B	43	44	2C	44	45	2D	45
46	2E	46	47	2F	47	48	30	48
49	31	49	50	32	50	51	33	51
52	34	52	53	35	53	54	36	54
55	37	55	56	38	56	57	39	57
58	3A	58	59	3B	59	60	3C	60
61	3D	61	62	3E	62	63	3F	63
64	40	64	65	41	65	66	42	66
67	43	67	68	44	68	69	45	69
70	46	70	71	47	71	72	48	72
73	49	73	74	4A	74	75	4B	75
76	4C	76	77	4D	77	78	4E	78
79	4F	79	80	50	80	81	51	81
82	52	82	83	53	83	84	54	84
85	55	85	86	56	86	87	57	87
88	58	88	89	59	89	90	5A	90
91	5B	91	92	5C	92	93	5D	93
94	5E	94	95	5F	95	96	60	96
97	61	97	98	62	98	99	63	99
100	64	100	101	65	101	102	66	102
103	67	103	104	68	104	105	69	105
106	6A	106	107	6B	107	108	6C	108
109	6D	109	110	6E	110	111	6F	111
112	70	112	113	71	113	114	72	114
115	73	115	116	74	116	117	75	117
118	76	118	119	77	119	120	78	120
121	79	121	122	7A	122	123	7B	123
124	7C	124	125	7D	125	126	7E	126
127	7F	127						

Programming Example

The following program is an examples of how to enable, disable and refresh the Watchdog timer:

```
WDT_EN_RF      equ      444H

WDT_DIS equ     044h

WT_Enable      push AX          ; Save AX,DX
                push DX
                mov DX,WDT_EN_RF ; Enable Timer
                mov AX,INTERVAL ; Set Timeout Value
                out DX,AX
                pop DX           ; Restore DX,AX
                pop AX
                ret

WT_Refresh     push AX          ; Save AX,DX
                push DX
                mov DX,WDT_EN_RF ; Refresh Timer
                mov AX,INTERVAL ; Set Timeout Value
                out DX,AX
                pop DX           ; Restore DX,AX
                pop AX
                ret

WT_Disable     push AX          ; Save AX,DX
                push DX
                mov DX,WDT_DIS   ; Disable Timer
                in  AX,DX
                pop DX           ; Restore DX,AX
                pop AX
                ret

WT_Disable     push AX          ; save AX,DX
                push DX
                mov DX,WDT_DIS   ; Disable Timer
                in  AX,DX
                pop DX           ; restore DX,AX
                pop AX
                ret
```

Fast Ethernet Connectors

LAN Port

Connector : **LAN1, LAN2**

Type : external RJ-45 on bracket

Pin	1	2	3	4	5	6	7	8
Description	TX+	TX-	RX+	NC	NC	RX-	NC	NC

LAN LED Indicator on RJ-45 connector

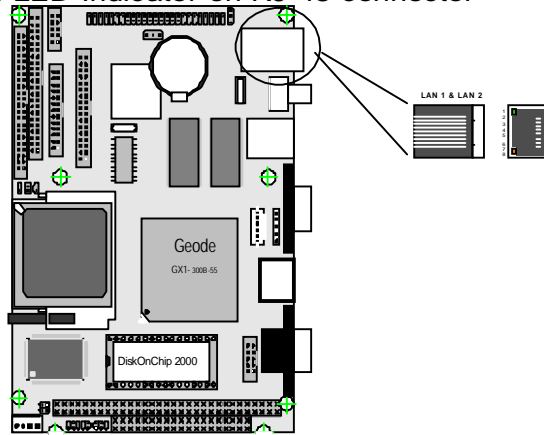

Power Connector

Power Connector : PWR1

Connector : **PWR1**

Type : PWR1: onboard small 4P connector

Pin	Description	Pin	Description
1	+5V	2	GND
3	GND	4	+12V

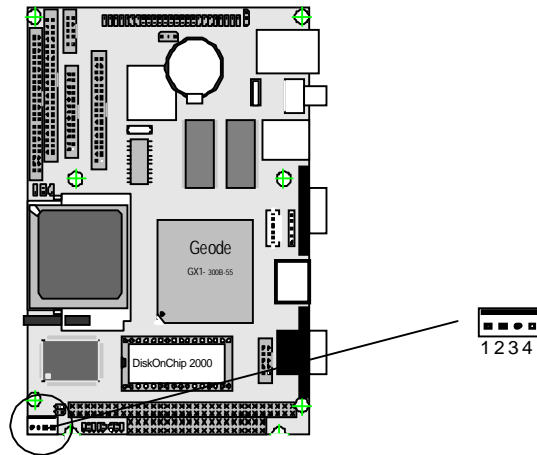

Switches and Indicators

Connector : **JFRT1**

Type : onboard 8-pin(2*4) header

Pin	Jumper	Description
1-2	PSON	ATX soft power switch
3-4	RES	Reset function
5-6	SMI	External SMI
7-8	SPEAKER	Speaker

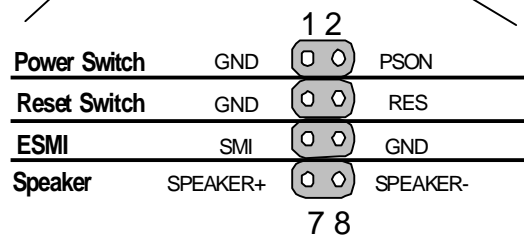
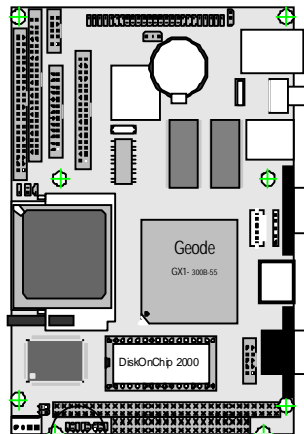

Connector : **RES1**
Type : onboard 2-pin header

Pin	Description
1	RES
2	GND

Connector : **HLED1**
Type : onboard 2-pin header

Pin	Description
1	HLED1+
2	GND

Connector : **PLED1**
Type : onboard 2-pin header

Pin	Description
1	PLED1+
2	GND

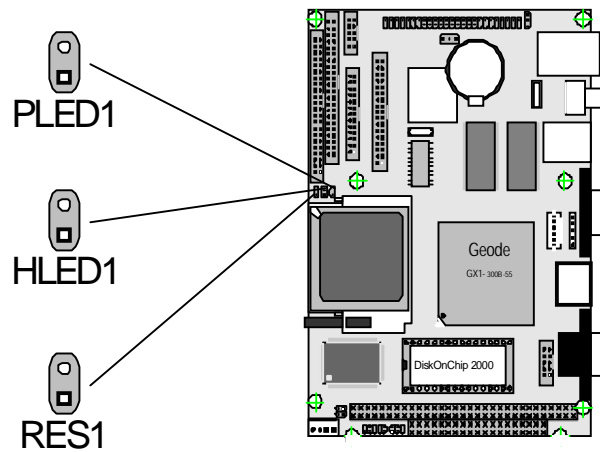

Interface Connectors HDD, FDD

Floppy Disk Drive Connector

Connector : **FDD**

Type : onboard 34-pin box header

Pin	Description	Pin	Description
1	GND	2	DRIVE DENSITY SELECT 0
3	GND	4	NC
5	GND	6	DRIVE DENSITY SELECT 1
7	GND	8	#INDEX
9	GND	10	#MOTOR ENABLE A
11	GND	12	#DRIVER SELECT B
13	GND	14	#DRIVER SELECT A
15	GND	16	#MOTOR ENABLE B
17	GND	18	#DIRECTION
19	GND	20	#STEP
21	GND	22	#WRITE DATA
23	GND	24	#WRITE GATE
25	GND	26	#TRACK 0
27	GND	28	#WRITE PROTECT
29	GND	30	#READ DATA
31	GND	32	#HEAD SELECT
33	GND	34	#DISK CHANGE

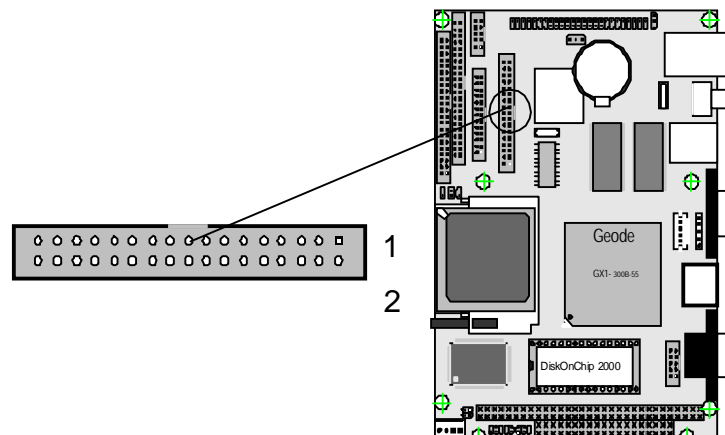

Enhanced IDE1,2 Connector

Connector : IDE1,2

Type : One onboard 44-pin box headers, primary IDE

Pin	Description	Pin	Description
1	#RESET	2	GND
3	D7	4	D8
5	D6	6	D9
7	D5	8	D10
9	D4	10	D11
11	D3	12	D12
13	D2	14	D13
15	D1	16	D14
17	D0	18	D15
19	GND	20	NC
21	REQ	22	GND
23	#IOW	24	GND
25	#IOR	26	GND
27	#IRDY	28	IDESEL
29	#DACK	30	GND
31	IRQ	32	NC
33	ADDR1	34	CBLID
35	ADDR0	36	ADDR2
37	#CS0	38	#CS1(#HD SELET1)
39	#ACT	40	GND
41	Vcc	42	Vcc
43	GND	44	GND

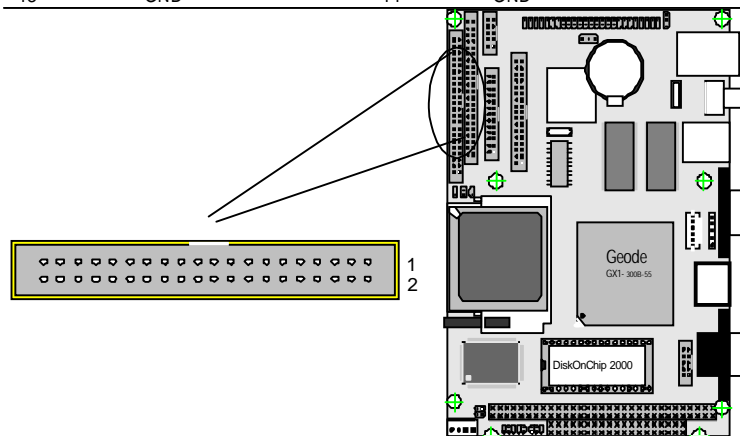

Peripheral Port

Parallel Port

Connector : **LPT**

Type : onboard 26-pin box header

Pin	Description	Pin	Description
1	#STROBE	14	#AUTO FEED
2	DATA0	15	#ERROR
3	DATA1	16	#INITIALIZE
4	DATA2	17	#SELECT INPUT
5	DATA3	18	GND
6	DATA4	19	GND
7	DATA5	20	GND
8	DATA6	21	GND
9	DATA7	22	GND
10	#ACKNOWLEDGE	23	GND
11	BUSY	24	GND
12	PAPER EMPTY	25	GND
13	SELECT	26	GND

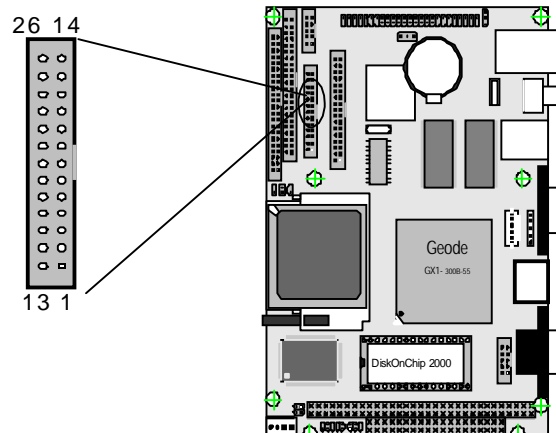

USB Ports

Connector: **USB1**

Type: onboard Two USB ports

Pin	Description	Pin	Description
1	VCC	2	DATA-
3	DATA+	4	GND

SIR

Connector : **SIR**

Type : onboard 5-pin header

Pin	Description	Pin	Description
1	Vcc	2	NC
3	IRRX	4	GND
5	IRTX		

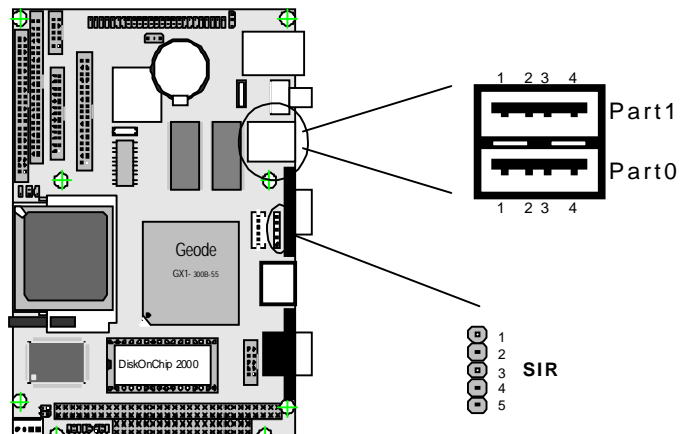

CRT SVGA

Connector : **VGA1**

Type : external 15-pin D-sub female connector on bracket

Pin	Description	Pin	Description	Pin	Description
1	RED	6	GND	11	NC
2	GREEN	7	GND	12	VDDAT
3	BLUE	8	GND	13	HSYNC
4	NC	9	Vcc	14	VSYNC
5	GND	10	GND	15	VDCLK

PS/2 Keyboard & Mouse

Connector: **KMB1,2**

Type: external 6-pin Mini DIN connector on bracket and 6-pin waver

Pin	Description	Pin	Description
1	KB-DATA	2	MS-DATA
3	GND	4	VCC
5	KB-CLK	6	MS-CLK

Note: KB1 supports PS/2 keyboard directly, and PS/2 mouse supported with the additional PS2 1-to-2 cable in the standard packing.

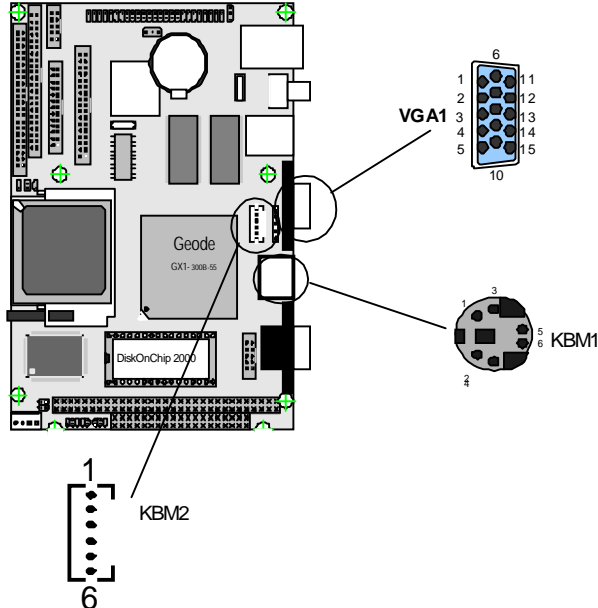

COM1 & COM2 for RS-232C Port

Connector : **COM1 & COM2**

Type : onboard 15-pin D-sub male connector (COM1) and 10-pin box header(COM2)

Pin	Description	Pin	Description
1	DCD	2	RXD
3	TXD	4	DTR
5	GND	6	DSR
7	RTS	8	CTS
9	RI	10	NC

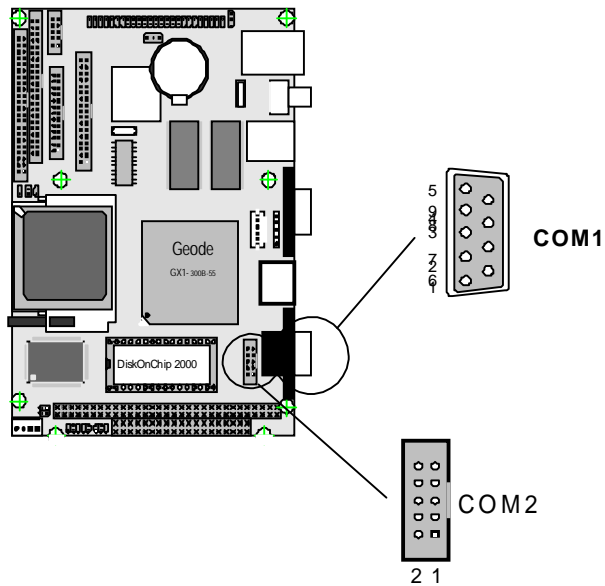

Compact Flash Connector

Connector : **CFD**

Type : 50-pin compact flash type I/II

Pin	Description	Pin	Description	Pin	Description
1	GND	18	ADDR2	35	IO WRITE
2	DATA3	19	ADDR1	36	+5V
3	DATA4	20	ADDR0	37	IRQ15
4	DATA5	21	DATA0	38	+5V
5	DATA6	22	DATA1	39	CSEL
6	DATA7	23	DATA2	40	N/C
7	CS#1	24	N/C	41	IDE RESET
8	GND	25	GND	42	IO READY
9	GND	26	GND	43	N/C
10	GND	27	DATA11	44	+5V
11	GND	28	DATA12	45	DASP
12	GND	29	DATA13	46	DIAG
13	+5V	30	DATA14	47	DATA8
14	GND	31	DATA15	48	DATA9
15	GND	32	CS#3	49	DATA10
16	GND	33	GND	50	GND
17	GND	34	IO READ		

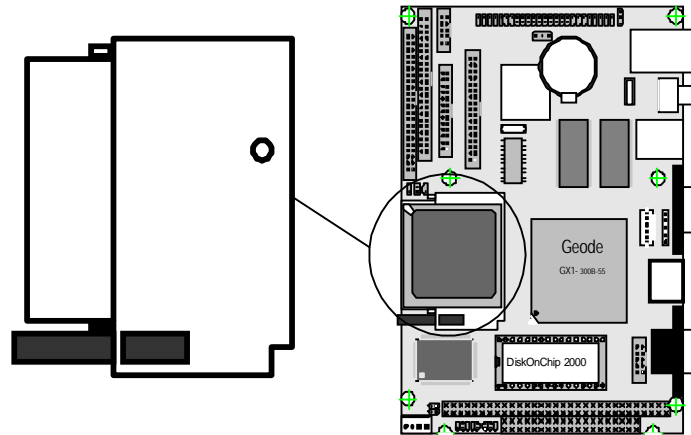

Compact Flash Disk

The interface of Compact Flash socket is designated to use IDE2.

Attention!

Installation Instructions

Compact Flash card is "**NOT HOT-SWAPPABLE**". If the CF card is swapped in the condition of system power-on, it will damage the CF card.

1. Make sure the Single Board Computer is powered OFF.
2. Plug the Compact Flash TypeI/II device into its socket. Verify the direction is correct on Secondary IDE which is located in the **back** of SBC.
3. Powre up the system

For more information on Compact Flash disk, visit Pretec Web site at

[http:// www.pretec.com](http://www.pretec.com)

where you can find the utilities manual, data sheets and application notes. In addition, you can find the latest Compact Flash disk utilities.

Audio Connector

Connector : **AUDIO**

Type :Onboard 10-pin box header

Pin	Description	Pin	Description
1	LINE-L_IN	2	LINE-R_IN
3	GND	4	GND
5	MIC_IN	6	NC
7	GND	8	GND
9	LINE-L_OUT	10	LINE-R_OUT

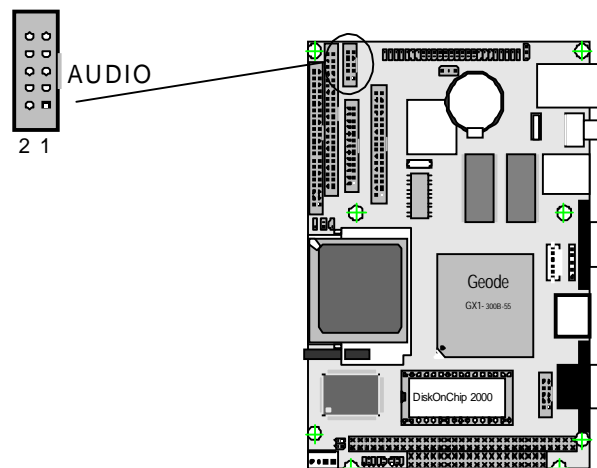

System Resources

Interrupt Assignment

IRQ Address	Description
0	System Timer
1	Standard 101/103-key or Microsoft Natural Keyboard
2	Programmable Interrupt Controller
3	Communication Port (COM2)
4	Communication Port (COM1)
5	National XpressAUDIO(TM) 16-bit Sound
6	Standard Floppy Disk Controller
7	Parallel Port 1 (LPT1)
8	System CMOS/real time clock
9	Reserve
10	Realtek RTL8139/810x Family Fast Ethernet NIC
11	Chips and Tech. 69000 PCI
12	PS/2 Compatible Mouse Port
13	Numeric data processor
14	Primary Cx5530 Bus Master IDE Controller
15	Secondary Cx5530 Bus Master IDE Controller

I/O Address Space

Adress	Description
0000 - 000F	DMA Controller
0020 - 0021	Programmable interrupt controller
0040 - 0043	System Timer
0060 - 0060	Standard 101/102-key or Microsoft Natural Keyboard
0061 - 0061	System speaker
0064 - 0064	Standard 101/102-key or Microsoft Natural Keyboard
0070 - 0071	System COM/real time clock
0087 - 0087	Direct memory access controller
0089 - 008B	Direct memory access controller
008F - 0091	Direct memory access controller
00A0 - 00A1	Programmable interrupt controller
00C0 - 00DF	Motherboard Resources
00F0 - 00FF	Nuneric data processor
0170 - 0177	Cyrix 5530 Bus Master PCI to Dual IDE Controller

0170 - 0177	Seoncdary Cx5530 Bus Master IDE Controller
01F0 - 01F7	Cyrix 5530 Bus Master PCI to Dual IDE Controller
01F0 - 01F7	Primary Cx5530 Bus Master IDE Controller
0220 - 022F	National XpressAUDIO(TM) 16-bit Sound
02F8 - 02FF	Communications Port(COM2)
0330 - 0331	National XpressAUDIO(TM) 16-bit Sound
0376 - 0376	Cyrix 5530 Bus Master PCI to Dual IDE Controller
0376 - 0376	Seoncdary Cx5530 Bus Master IDE Controller
0378 - 037F	Printer Port (LPT1)
0388 - 038B	National XpressAUDIO(TM) 16-bit Sound
03B0 - 03BB	Chips and Tech. 69000 PCI
03C0 - 03DF	Chips and Tech. 69000 PCI
03F2 - 03F5	Standard Floppy Disk Controller
03F6 - 03F6	Cyrix 5530 Bus Master PCI to Dual IDE Controller
03F6 - 03F6	Primary Cx5530 Bus Master IDE Controller
03F8 - 03FF	Communications Port(COM1)
0480 - 048F	PCI bus
04D0 - 04D1	PCI bus
0CF8 - 0CFF	PCI bus
E000 - E0FF	Realtek RTL8139/810x Family Fast Ethernet NIC
F000 - F00F	Primary Cx5530 Bus Master IDE Controller
F000 - F00F	Cyrix 5530 Bus Master PCI to Dual IDE Controller
F000 - F007	Primary Cx5530 Bus Master IDE Controller
F008 - F00F	Seoncdary Cx5530 Bus Master IDE Controller

Flat Panel VGA

Flat Panel VGA (LCD) : LCD1



C&T69000 18/24-bit

Pin	Description	Pin	Description
1	+12V	2	+12V
3	GND	4	GND
5	VCC_LCD	6	ENAVDD
7	ENAVEE	8	GND
9	B0	10	B1
11	B2	12	B3
13	B4	14	B5
15	B6	16	B7
17	G0	18	G1
19	G2	20	G3
21	G4	22	G5
23	G6	24	G7
25	R0	26	R1
27	R2	28	R3
29	R4	30	R5
31	R6	32	R7
33	NC	34	NC
35	SHFCLK	36	FLM
37	M	38	LP
39	GND	40	ENABKL
41	NC	42	NC
43	NC	44	NC
45	NC	46	NC
47	NC	48	NC
49	NC	50	NC

Flat Panel VGA

Flat Panel VGA (LCD) : LCD1

C&T69000 18/24-bit

Pin	Description	Pin	Description
1	+12V	2	+12V
3	GND	4	GND
5	VCC_LCD	6	ENAVDD
7	ENAVEE	8	GND
9	B0	10	B1
11	B2	12	B3
13	B4	14	B5
15	B6	16	B7
17	G0	18	G1
19	G2	20	G3
21	G4	22	G5
23	G6	24	G7
25	R0	26	R1
27	R2	28	R3
29	R4	30	R5
31	R6	32	R7
33	NC	34	NC
35	SHFCLK	36	FLM
37	M	38	LP
39	GND	40	ENABKL
41	NC	42	NC
43	NC	44	NC
45	NC	46	NC
47	NC	48	NC
49	NC	50	NC

Flat Panel VGA

Flat Panel VGA (LCD) : LCD1

CS5530A 18-bit

Pin	Description	Pin	Description
1	+12V	2	+12V
3	GND	4	GND
5	VCC_LCD	6	ENAVDD
7	ENAVEE	8	GND
9	B0	10	B1
11	B2	12	B3
13	B4	14	B5
15	G0	16	G1
17	G2	18	G3
19	G4	20	G5
21	R0	22	R1
23	R2	24	R3
25	R4	26	R5
27	NC	28	NC
29	NC	30	NC
31	NC	32	NC
33	NC	34	NC
35	SHFCLK	36	FLM
37	M	38	LP
39	GND	40	ENABKL
41	NC	42	NC
43	NC	44	NC
45	NC	46	NC
47	NC	48	NC
49	NC	50	NC

AWARD BIOS Setup

The SBC uses the Award PCI/ISA BIOS ver 4.5 for the system configuration. The Award BIOS setup program is designed to provide the maximum flexibility in configuring the system by offering various options which could be selected for end-user requirements. This chapter is written to assist you in the proper usage of these features.

To access AWARD PCI/ISA BIOS Setup program, press key. The Main Menu will be displayed at this time.

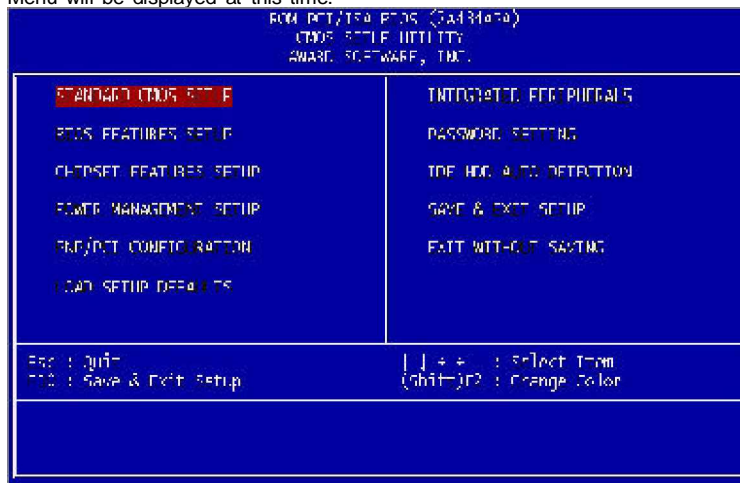

Once you enter the AwardBIOS?CMOS Setup Utility, the Main Menu will appear on the screen. The Main Menu allows you to select from several setup functions and two exit choices. Use the arrow keys to select among the items and press <Enter> to accept and enter the sub-menu.

Setup Items

The main menu includes the following main setup categories. Recall that some systems may not include all entries.

CMOS FEATURES SETUP

Use this menu for basic system configuration.

BIOS FEATURES SETUP

Use this menu to set the Advanced Features available on your system.

CHIPSET FEATURES SETUP

Use this menu to change the values in the chipset registers and optimize your system's performance.

Power Management Setup

Use this menu to specify your settings for power management.

PnP / PCI CONFIGURATION

This entry appears if your system supports PnP / PCI.

LOAD OPTIMIZED DEFAULTS

Use this menu to load the BIOS default values that are factory settings for optimal performance system operations. While Award has designed the custom BIOS to maximize performance, the factory has the right to change these defaults to meet their needs.

INTEGRATED PERIPHERALS

Use this menu to specify your settings for integrated peripherals.

SET PASSWORD

Use this menu to set User and Supervisor Passwords.

IDE HDD AUTO DETECTION

System will detect the HDD plugged and recognizes what type it is.

SAVE & EXIT SETUP

Save CMOS value changes to CMOS and exit setup.

EXIT WITHOUT SAVE

Abandon all CMOS value changes and exit setup.

Standard CMOS Setup

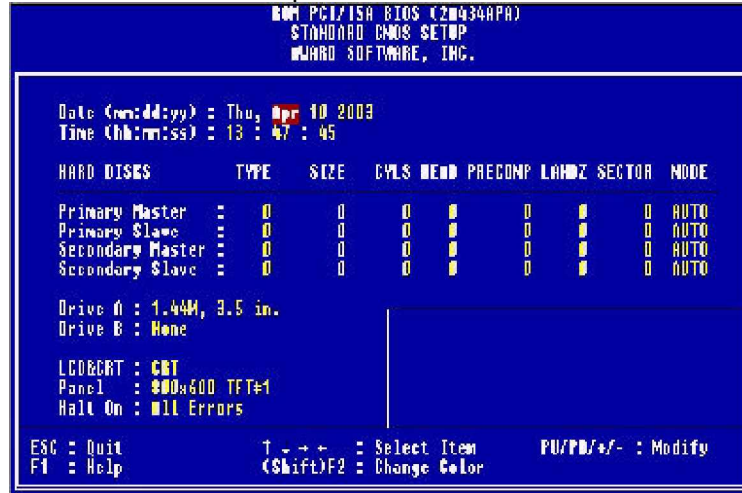

↑ ↓ → ← : Move Enter: Select +/-/PU/PD: Value F10: Save ESC: Exit F1: General Help
F5: Previous Values F6: Fail-Safe Defaults F7: Optimized Defaults

Date

The BIOS determines the day of the week from the other date information; this field is for information only.

Time

The time format is based on the 24-hour military-time clock. For example, 1 p.m. is 13:00:00. Press the ? or (key to move to the desired field. Press the PgUp or PgDn key to increment the setting, or type the desired value into the field.

IDE Primary Master/Slave

IDE Secondary Master/Slave

Options are in sub menu (see page 30)

Drive A, B

Select the correct specifications for the diskette drive(s) installed in the computer.

None :	No diskette drive installed
360K ;	5.25 in 5-1/4 inch PC-type standard drive
1.2M ;	5.25 in 5-1/4 inch AT-type high-density drive
720K ;	3.5 in 3-1/2 inch double-sided drive
1.44M ;	3.5 in 3-1/2 inch double-sided drive
2.88M ;	3.5 in 3-1/2 inch double-sided drive

LCD&CRT Select the type of primary video subsystem in your computer. The BIOS usually detects the correct video type automatically. The BIOS supports a secondary video subsystem, but you do not select it in Setup.

Panel Type Select the different panel type to run the system. Four various resolutions for TFT type and two for DSTN.

Halt On During the power-on self-test (POST), the computer stops if the BIOS detects a hardware error. You can tell the BIOS to ignore certain errors during POST and continue the boot-up process. These are the selections:

No errors	POST does not stop for any errors.
All errors	If the BIOS detects any non-fatal error, POST stops and prompts you to take corrective action.
All, But Keyboard	POST does not stop for a keyboard error, but stops for all other errors.
All, But Diskette	POST does not stop for diskette drive errors, but stops for all other errors.
All, But Disk/Key	POST does not stop for a keyboard or disk error, but stops for all other errors.

BIOS Features Setup

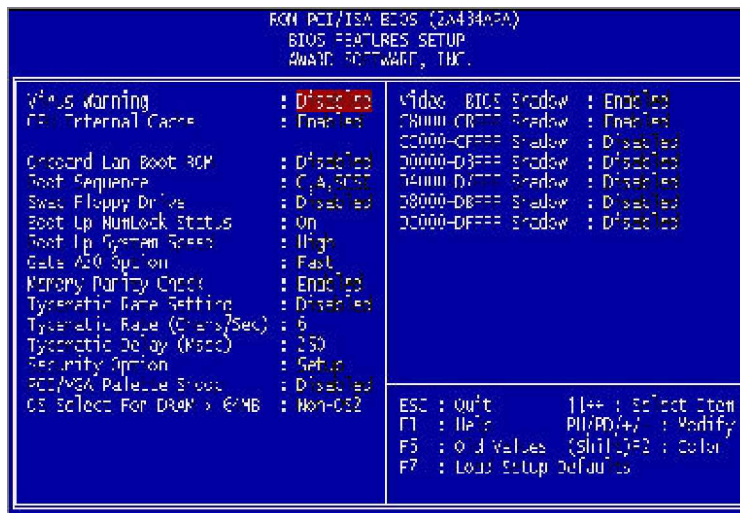

↑ ↓ → ← : Move Enter: Select +/- /PU/PD: Value F10: Save ESC: Exit F1: General Help
 F5: Previous Values F6: Fail-Safe Defaults F7: Optimized Defaults

Virus Warning

Allows you to choose the VIRUS Warning feature for IDE Hard Disk boot sector protection. If this function is enabled and someone attempt to write data into this area, BIOS will show a warning message on screen and beep.

Enabled Activates automatically when the system boots up causing a warning message to appear when anything attempts to access the boot sector or hard disk partition table.

Disabled No warning message will appear when anything attempts to access the boot sector or hard disk partition table.

CPU Internal Cache

These two categories speed up memory access. However, it depends on CPU/chipset design. Enabled : Enable cache, Disabled : Disable cache.

Onboard LAN Boot ROM

This feature allows you to run LAN Boot function. Select "Disabled" not to access this function.

Boot Sequence

The BIOS attempts to load the operating system from the devices in the sequence selected in these items. The choices are : Floppy, HDD, CDROM, Disabled.

Swap Floppy Drive

If the system has two floppy drives, you can swap the logical drive name assignments. The choice: Enabled/Disabled.

Boot Up NumLock Status

Select power on state for NumLock. The choice: Enabled/Disabled.

Boot Up System Speed

This item will speed up the sequence of system POST .

Gate A20 Option

Select if chipset or keyboard controller should control GateA20.

Normal A pin in the keyboard controller controls GateA20

Fast Lets chipset control GateA20

Typematic Rate Setting

Key strokes repeat at a rate determined by the keyboard controller. When enabled, the typematic rate and typematic delay can be selected.

The choice: Enabled/Disabled.

Typematic Rate (Chars/Sec)

Sets the number of times a second to repeat a key stroke when you hold the key down. The choice: 6, 8, 10, 12, 15, 20, 24, 30.

Typematic Delay (Msec)

Sets the delay time after the key is held down before it begins to repeat the keystroke. The choice: 250, 500, 750, 1000.

Security Option

Select whether the password is required every time the system boots or only when you enter setup.

System The system will not boot and access to Setup will be denied if the correct password is not entered at the prompt.

Setup The system will boot, but access to Setup will be denied if the correct password is not entered at the prompt.

Note To disable security, select PASSWORD SETTING at Main Menu and then you will be asked to enter password. Do not type anything and just press <Enter>, it will disable security. Once the security is disabled, the system will boot and you can enter Setup freely.

PCI/VGA Palette Snoop

Normally this option is always Disabled! Nonstandard VGA display adapters such as overlay cards or MPEG video cards may not show colors properly. Setting Enabled should correct this problem. If this field set Enabled, any I/O access on the ISA bus to the VGA card's palette registers will be reflected on the PCI bus. This will allow overlay cards to adapt to the changing palette colors.

OS Select For DRAM > 64MB

Select the operating system that is running with greater than 64MB of RAM on the system. The choice: Non-OS2, OS2.

Video BIOS Shadow

Enabled this copies the video BIOS from ROM to RAM. effectively enhancing performance, and reducing the amount of upper memory available by 32KB (the C000~C7FFF area of memory between 640 KB and 1 MB is used).

C8000-CBFFF Shadow

Enabling any of the C8000~CBFFF segments allows components to move their firmware into these upper memory segments. However your computer can lock-up doing so, because some devices don't like being shadowed at those particular 16 KB segments of upper memory.

Note - In Windows 95, double click 'Computer' within Device Manager and select 'Memory'. This will tell you what segments (if any) are being shadowed. For DOS you can use MSD.EXE to see what segments are claimed.
CC000-CFFFF - D0000-D3FFF - D4000-D7FFF - D8000-DBFFF and
DC000-DFFFF - Same as above.

Chipset Features Setup

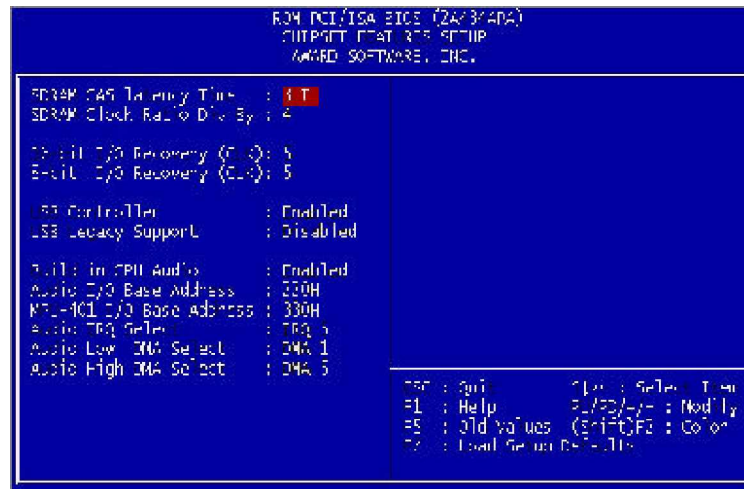

↑ ↓ → ← : Move Enter : Select +/- /PU/PD : Value F10 : Save ESC : Exit F1 : General Help
F5 : Previous Values F6 : Fail-Safe Defaults F7 : Optimized Defaults

SDRAM CAS latency Time

It controls the time delay (in clock cycles - CLKs) that passes before the SDRAM starts to carry out a read command after receiving it. This also determines the number of CLKs for the completion of the first part of a burst transfer. Thus, the lower the cycle length, the faster the transaction. However, some SDRAM cannot handle the lower cycle length and may become unstable. So, set the SDRAM Cycle Length to 2T for optimal performance if possible but increase it to 3T if your system becomes unstable.

SDRAM Clock Ration Div By

The function will setup the speed of DRAM .

16-bit I/O Recovery(CLK)

The recovery time is the length of time measured in CPU clocks , which the system will delay after the completion of an input/output request . This delay takes place because the CPU is operating so much faster than the input/output bus that the CPU must be delayed to allow for the completion of the I/O

This item allows to you to derermine the recovery time allowed for 16-bit I/O. Choices are from 1 to 8 CPU Clocks.

8-bit I/O Recovery(CLK)

This item allows to you to derermine the recovery time allowed for 8-bit I/O. Choices are from 1 to 4 CPU Clocks.

USB Controller

If your system contains a Universal Serial Bus controller and you have a USB peripheral, select Enabled. The next option will become available.

USB Legacy Support

This item lets you enable or disable the USB devices within the onboard BIOS.

Built in CPU Audio

Configuration options: Enabled and Disabled. When Enabled, select additional settings for SoundBlaster Compatibility and MPU-401 functionality

Power Management Setup

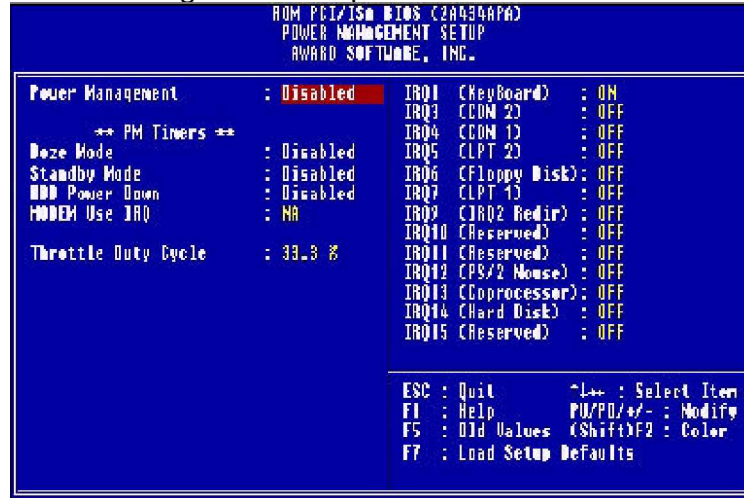

↑ ↓ → ← : Move Enter: Select +/-/PU/PD: Value F10: Save ESC: Exit F1: General Help
F5: Previous Values F6: Fail-Safe Defaults F7: Optimized Defaults

Power Management

Enable the item will enable the power management function.

Doze Mode

After the selected period of drive inactivity, the hard disk drive powers down while all other devices remain active.

Standby Mode

After the selected period of system inactivity, the fixed disk drive and the video shut off while all other devices still operate at full speed.

HDD Power Down

After the selected period of HDD inactivity, the HDD will be shut down .

Modem Use IRQ

Name the interrupt request (IRQ) assigned to the modem (if any) on your system. Activity of the selected IRQ always awakens the system.

PnP/PCI Configuration



↑↓→←:Move Enter:Select +/-/PU/PD:Value F10:Save ESC:Exit F1:General Help
F5:Previous Values F6:Fail-SAFE Defaults F7:Optimized Defaults

This section describes configuring the PCI bus system. PCI, or Personal Computer Interconnect, is a system which allows I/O devices to operate at speeds nearing the speed the CPU itself uses when communicating with its own special components.

PnP OS Installed

Select Yes if the system operating environment is Plug-and-Play aware (e.g., Windows 95).

Resource Controlled By

The Award Plug and Play BIOS can automatically configure all the boot and Plug-and-Play compatible devices. If you select Auto, all the interrupt request (IRQ) and DMA assignment fields disappear, as the BIOS automatically assigns them.

Reset Configuration Data

Normally, you leave this field Disabled. Select Enabled to reset ESCD (Extended System Configuration Date) when you exit Setup if you have installed a new add-on and the system reconfiguration has caused such a serious conflict that the operating system cannot boot.

Integrated Peripherals

ROM BIOS/TPM PTIO (7a434afa) INTEGRATED PERIPHERALS AWARD SOFTWARE, INC.			
IDE HDD Block Mode	: Enabled	TP Transmission delay	: Enabled
Primary IDE Channel	: Enabled	TP IRQ Select	:
Master Drive PIO Mode	: Auto	TP Mode Use DMA	: Disabled
Slave Drive PIO Mode	: Auto	Onboard Parallel Port	:
Secondary IDE Channel	: Enabled	Parallel Port Mode	:
Master Drive PIO Mode	: Auto	FPP Mode Use DMA	:
Slave Drive PIO Mode	: Auto	FPP Mode Select	: Floppy
		Onboard Fax	: Enabled
IDE Primary Master DMA	: Auto		
IDE Primary Slave DMA	: Auto		
IDE Secondary Master DMA	: Auto		
IDE Secondary Slave DMA	: Auto		
KBC Input Clock	: 8 MHz		
Onboard FDC Controller	: Enabled	F7 : Quit	: Set Exit Tran
Onboard Serial Port 1	: 3F8/IRQ4	F8 : Help	/ : Modify
Onboard Serial Port 2	: 2F8/IRQ3	F9 : Old Values	<Shift> : Polar
Onboard TC Controller	:	F0 : Load Setup Defaults	
TC Address Select	: 3000		
TP Mode	:		

↑ ↓ → ← : Move Enter: Select +/- /PU/PD: Value F10: Save ESC: Exit F1: General Help
F5: Previous Values F6: Fail-Safe Defaults F7: Optimized Defaults

IDE HDD Block Mode

This feature enhances disk performance by allowing multi-sector data transfers and eliminates the interrupt handling time for each sector.

Primary/Secondary IDE Channel

Select "Enabled" to activate each on-board IDE channel separately. Select "Disabled", if you install an add-on IDE Control card

Primary & Secondary Master/Slave PIO

These four PIO fields let you set a PIO mode (0-4) for each of four IDE devices. When under "Auto" mode, the system automatically set the best mode for each device

Primary & Secondary Master/Slave UDMA

When set to "Auto" mode, the system will detect if the hard drive supports Ultra DMA mode.

KBC input clock

This item will set the frequency of Keyboard controller.

Onboard FDC Controller

Configuration options: Enabled and Disabled. Enable the Floppy Disk Controller. The default setting is "Enabled".

Onboard Serial Port 1 & 2

Select an address and corresponding interrupt for the first/second serial port. The default value for the first serial port is "3F8/IRQ4" and the second serial port is "2F8/IRQ3".

Onboard IR Controller

This item allows you to select UART mode. The choices: IrDA, ASKIR, Normal.

IR Address Select

This item allows you to determine which I/O address you need .

IR Mode

This item allows you to determine which mode you need (IrDA, ASKIR, Normal).

IR Transmission delay

You can delay the transmission rate of IR for compatibility for other device by setting this item.

IR IRQ Select

This item allows you to determine which IRQ you need .

IR DMA Select

This item allows you to determine which DMA channel you need .

Onboard Parallel Port

Select address and interrupt for the Parallel port.

Onboard Parallel Mode

Select an operating mode for the parallel port. Mode options are Normal, EPP, ECP, ECP/EPP.

ECP Mode Use DMA

Select a DMA channel if parallel Mode is set as ECP, ECP/EPP.

EPP Mode Select

Select a EPP Type if parallel Port is set as EPP, ECP/EPP.

Onboard LAN

Select "Enabled" if your system contains a LAN port.

POST Codes

The following codes are not displayed on the screen. They can only be viewed on the LED display of a so called POST card. The codes are listed in the same order as the according functions are executed at PC startup. If you have access to a POST Card reader, you can watch the system perform each test by the value that's displayed. If the system hangs (if there's a problem) the last value displayed will give you a good idea where and what went wrong, or what's bad on the system board.

CODE	DESCRIPTION OF CHECK
CFh	Test CMOS R/W functionality.
C0h	Early chipset initialization: -Disable shadow RAM -Disable L2 cache (socket 7 or below) -Program basic chipset registers
C1h	Detect memory -Auto-detection of DRAM size, type and ECC. -Auto-detection of L2 cache (socket 7 or below)
C3h	Expand compressed BIOS code to DRAM
C5h	Call chipset hook to copy BIOS back to E000 & F000 shadow RAM.
0h1	Expand the Xgroup codes locating in physical address 1000:0
02h	Reserved
03h	Initial Superio_Early_Init switch.
04h	Reserved
05h	1. Blank out screen 2. Clear CMOS error flag
06h	Reserved
07h	1. Clear 8042 interface 2. Initialize 8042 self-test
08h	1. Test special keyboard controller for Winbond 977 series Super I/O chips. 2. Enable keyboard interface.
09h	Reserved
0Ah	1. Disable PS/2 mouse interface (optional). 2. Auto detect ports for keyboard & mouse followed by a port & interface swap (optional). 3. Reset keyboard for Winbond 977 series Super I/O chips.
0Bh	Reserved
0Ch	Reserved

0Dh	Reserved
0Eh	Test F000h segment shadow to see whether it is R/W-able or not. If test fails, keep beeping the speaker.
0Fh	Reserved
10h	Auto detect flash type to load appropriate flash R/W codes into the run time area in F000 for ESCD & DMI support.
11h	Reserved
12h	Use walking 1's algorithm to check out interface in CMOS circuitry. Also set real-time clock power status, and then check for override.
13h	Reserved
14h	Program chipset default values into chipset. Chipset default values are MODBINable by OEM customers.
15h	Reserved
16h	Initial onboard clock generator if Early_Init_Onboard_Generator is defined. See also POST 26h.
17h	Reserved
18h	Detect CPU information including brand, SMI type (Cyrix or Intel) and CPU level (586 or 686).
19h	Reserved
1Ah	Reserved
1Bh	Initial interrupts vector table. If no special specified, all H/W interrupts are directed to SPURIOUS_INT_HDLR & S/W interrupts to SPURIOUS_soft_HDLR.
1Ch	Reserved
1Dh	Initial EARLY_PM_INIT switch.
1Eh	Reserved
1Fh	Load keyboard matrix (notebook platform)
20h	Reserved
21h	HPM initialization (notebook platform)
22h	Reserved
23h	1. Check validity of RTC value: e.g. a value of 5Ah is an invalid value for RTC minute. 2. Load CMOS settings into BIOS stack. If CMOS checksum fails, use default value instead.
24h	Prepare BIOS resource map for PCI & PnP use. If ESCD is valid, take into consideration of the ESCD's legacy information.

25h	Early PCI Initialization: -Enumerate PCI bus number. -Assign memory & I/O resource -Search for a valid VGA device & VGA BIOS, and put it into C000:0
26h	1. If Early_Init_Onboard_Generator is not defined Onboard clock generator initialization. Disable respective clock resource to empty PCI & DIMM slots. 2. Init onboard PWM 3. Init onboard H/W monitor devices
27h	Initialize INT 09 buffer
28h	Reserved
29h	1. Program CPU internal MTRR (P6 & PII) for 0-640K memory address. 2. Initialize the APIC for Pentium class CPU. 3. Program early chipset according to CMOS setup. Example: onboard IDE controller. 4. Measure CPU speed.
2Ah	Reserved
2Bh	Invoke Video BIOS
2Ch	Reserved
2Dh	1. Initialize double-byte language font (Optional) 2. Put information on screen display, including Award title, CPU type, CPU speed, full screen logo.
2Eh	Reserved
2Fh	Reserved
30h	Reserved
31h	Reserved
32h	Reserved
33h	Reset keyboard if Early_Reset_KB is defined e.g. Winbond 977 series Super I/O chips. See also POST 63h.
34h	Reserved
35h	Test DMA Channel 0
36h	Reserved
37h	Test DMA Channel 1.
38h	Reserved
39h	Test DMA page registers.
3Ah	Reserved
3Bh	Reserved

3Ch	Test 8254
3Dh	Reserved
3Eh	Test 8259 interrupt mask bits for channel 1.
3Fh	Reserved
40h	Test 8259 interrupt mask bits for channel 2.
41h	Reserved
42h	Reserved
43h	Test 8259 functionality.
44h	Reserved
45h	Reserved
46h	Reserved
47h	Initialize EISA slot
48h	Reserved
49h	<ol style="list-style-type: none"> 1. Calculate total memory by testing the last double word of each 64K page. 2. Program write allocation for AMD K5 CPU.
4Ah	Reserved
4Bh	Reserved
4Ch	Reserved
4Dh	Reserved
4Eh	<ol style="list-style-type: none"> 1. Program MTRR of M1 CPU 2. Initialize L2 cache for P6 class CPU & program CPU with proper cacheable range. 3. Initialize the APIC for P6 class CPU. 4. On MP platform, adjust the cacheable range to smaller one in case the cacheable ranges between each CPU are not identical.
4Fh	Reserved
50h	Initialize USB Keyboard & Mouse.
51h	Reserved
52h	Test all memory (clear all extended memory to 0)
53h	Clear password according to H/W jumper (Optional)
54h	Reserved
55h	Display number of processors (multi-processor platform)
56h	Reserved

57h	1. Display PnP logo 2. Early ISA PnP initialization -Assign CSN to every ISA PnP device.
58h	Reserved
59h	Initialize the combined Trend Anti-Virus code.
5Ah	Reserved
5Bh	(Optional Feature) Show message for entering AWDFLASH.EXE from FDD (optional)
5Ch	Reserved
5Dh	1. Initialize Init_Onboard_Super_IO 2. Initialize Init_Onboard_AUDIO.
5Eh	Reserved
5Fh	Reserved
60h	Okay to enter Setup utility; i.e. not until this POST stage can users enter the CMOS setup utility.
61h	Reserved
62h	Reserved
63h	Reset keyboard if Early_Reset_KB is not defined.
64h	Reserved
65h	Initialize PS/2 Mouse
66h	Reserved
67h	Prepare memory size information for function call: INT 15h ax=E820h
68h	Reserved
69h	Turn on L2 cache
6Ah	Reserved
6Bh	Program chipset registers according to items described in Setup & Auto-configuration table.
6Ch	Reserved
6Dh	1. Assign resources to all ISA PnP devices. 2. Auto assign ports to onboard COM ports if the corresponding item in Setup is set to "AUTO".
6Eh	Reserved
6Fh	1. Initialize floppy controller 2. Set up floppy related fields in 40:hardware.
70h	Reserved

71h	Reserved
72h	Reserved
73h	(Reserved
74h	Reserved
75h	Detect & install all IDE devices: HDD, LS120, ZIP, CDROM?.
76h	(Optional Feature) Enter AWDFLASH.EXE if: -AWDFLASH.EXE is found in floppy drive. -ALT+F2 is pressed.
77h	Detect serial ports & parallel ports.
78h	Reserved
79h	Reserved
7Ah	Detect & install co-processor
7Bh	Reserved
7Ch	Init HDD write protect.
7Dh	Reserved
7Eh	Reserved
7Fh	Switch back to text mode if full screen logo is supported. - If errors occur, report errors & wait for keys - If no errors occur or F1 key is pressed to continue : wClear EPA or customization logo.
80h	Reserved
81h	Reserved

E8POST.ASM starts

82h	1. Call chipset power management hook. 2. Recover the text font used by EPA logo (not for full screen logo) 3. If password is set, ask for password.
83h	Save all data in stack back to CMOS
84h	Initialize ISA PnP boot devices
85h	1. USB final Initialization 2. Switch screen back to text mode
86h	Reserved
87h	NET PC: Build SYSID Structure.
88h	Reserved

89h	<ol style="list-style-type: none"> 1. Assign IRQs to PCI devices 2. Set up ACPI table at top of the memory.
8Ah	Reserved
8Bh	<ol style="list-style-type: none"> 1. Invoke all ISA adapter ROMs 2. Invoke all PCI ROMs (except VGA)
8Ch	Reserved
8Dh	<ol style="list-style-type: none"> 1. Enable/Disable Parity Check according to CMOS setup 2. APM Initialization
8Eh	Reserved
8Fh	Clear noise of IRQs
90h	Reserved
91h	Reserved
92h	Reserved
93h	Read HDD boot sector information for Trend Anti-Virus code
94h	<ol style="list-style-type: none"> 1. Enable L2 cache 2. Program Daylight Saving 3. Program boot up speed 4. Chipset final initialization. 5. Power management final initialization 6. Clear screen & display summary table 7. Program K6 write allocation 8. Program P6 class write combining
95h	Update keyboard LED & typematic rate
96h	<ol style="list-style-type: none"> 1. Build MP table 2. Build & update ESCD 3. Set CMOS century to 20h or 19h 4. Load CMOS time into DOS timer tick 5. Build MSIRQ routing table.
FFh	Boot attempt (INT 19h)

Howto : Flash the BIOS

To flash your BIOS you'll need

- 1) a xxxxx.bin file that is a file image of the new BIOS
- 2) AWDFLASH.EXE a utility that can write the data-file into the BIOS chip.

Create a new, clean DOS 6 bootable floppy with "format a: /s".

Copy flash utility and the BIOS image file to this disk.

Turn your computer off. Insert the floppy you just created and boot the computer. As it boots up, hit the [DEL] key to enter the CMOS setup. Go to "LOAD SETUP (or BIOS) DEFAULTS," and then save and exit the setup program. Continue to boot with the floppy disk.

Type "AWDFLASH" to execute the flash utility. When prompted, enter the name of the new BIOS image and begin the flash procedure. Note: If you reboot now, you may not be able to boot again.

After the flash utility is complete, reboot the system.

What to do when the Award flasher says: Insufficient memory

1. In CMOS Chipset Features Setup, Disable Video Bios Cacheable.
2. Hit Esc, F10, Save and exit.
3. Flash the BIOS and reboot
4. Enter CMOS Chipset Features Setup, and Enable Video Bios Cacheable, hit Esc, F10, Save and reboot.

What if things go wrong

if you use the wrong Flash BIOS or if the writing process gets interrupted, there is a fat chance that your computer won't boot anymore.

How can you recover a corrupt BIOS ?

Boot-block booting (this works only for Award BIOS)

Modern motherboards based on Award BIOS have a boot-block BIOS. This is small area of the BIOS that doesn't get overwritten when you flash a BIOS. The boot-block BIOS only has support for the floppy drive. If you have the AGP video enabled you won't see anything on the screen because the boot-block BIOS only supports an ISA videocard.

If you do not want to change your AGP video setting than proceed as follows:

The boot-block BIOS will execute an AUTOEXEC.BAT file on a bootable diskette. Copy an Award flasher & the correct BIOS *.bin file on the floppy and execute it automatically by putting awdf flash *.bin in the AUTOEXEC.BAT file.

Solution 2: Hot-swapping

1. Replace the corrupt chip by a working one. The working BIOS doesn't have to be written for your board, it just has to give you a chance of booting to DOS.

BIOSs for the same chipset mostly work. (Chipsets that not differ too much also mostly work. (e.g. Triton FX chipset and Triton HX chipset)

2. Boot the system to DOS (with floppy or HD)

3. Be sure that the System BIOS cacheable option in your BIOS is enabled! If so replace (while the computer is powered on) the BIOS chip with the corrupt one. This should work fine with most boards because the BIOS is shadowed in RAM.

4. Flash an appropriate BIOS to the corrupt chip and reboot.

NOTE Use a flasher from MRBIOS (<http://www.mrbios.com>). Utilities that come with your motherboard often use specific BIOS-hooks. Because you have booted with a BIOS not written for your motherboard they usually don't work. The MR Flash utilities communicate directly with your Flash Rom and always work. In most cases they flash a non-MRBIOS to your BIOS chip without problems.

Warranty

This product is warranted to be in good working order for a period of one year from the date of purchase. Should this product fail to be in good working order at any time during this period, we will, at our option, replace or repair it at no additional charge except as set forth in the following terms. This warranty does not apply to products damaged by misuse, modifications, accident or disaster.

Vendor assumes no liability for any damages, lost profits, lost savings or any other incidental or consequential damage resulting from the use, misuse of, or inability to use this product. Vendor will not be liable for any claim made by any other related party.

Return authorization must be obtained from the vendor before returned merchandise will be accepted. Authorization can be obtained by calling or faxing the vendor and requesting a Return Merchandise Authorization (RMA) number. Returned goods should always be accompanied by a clear problem description.

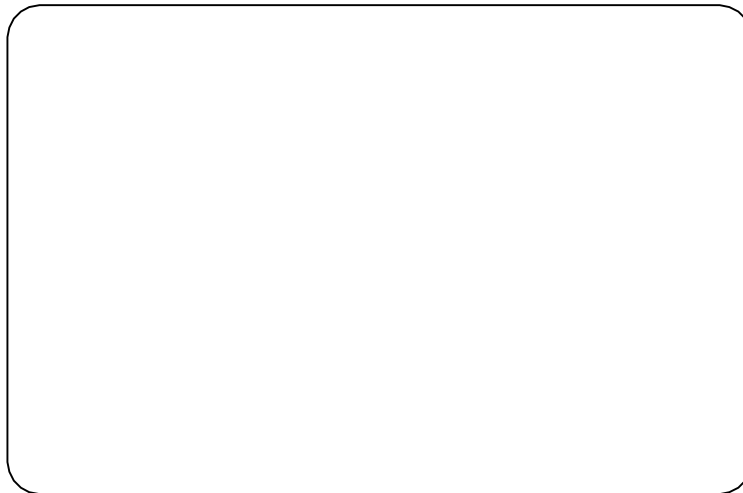

Any advice or comments about our products and service, or anything we can help you with please don't hesitate to contact with us. We will do our best to support you for your products, projects and business

Global American Inc.

Address: 17 Hampshire Drive
Hudson, NH 03051

TEL: Toll Free (U.S. Only) 800-833-8999
(603)886-3900

FAX: (603)886-4545

Website: <http://www.globalamericaninc.com>

E-Mail: salesinfo@globalamericaninc.com

