



User's Manual

3007632

1. TABLE OF CONTENTS

1. TABLE OF CONTENTS	2
2. USER INFORMATION.....	4
2.1 Trademarks	4
2.2 General	4
2.3 Warranty	4
2.4 Support, problems and failure analysis	5
3. INTRODUCTION	6
4. FEATURES.....	7
5. I/O MAP	8
6. BLOCK DIAGRAM.....	9
7. CONNECTOR ARRANGEMENT	10
8. BIOS-DESCRIPTION	11
8.1 The Setup Guide.....	11
8.2 Boot Utilities.....	21
8.3 BIOS Update with Phoenix Phlash.....	22
8.4 Boot Block Support.....	23
9. HARDWARE DESCRIPTION.....	24
9.1 ALI-Chipset Features.....	24
9.2 Memory configuration	24
9.3 Interrupts.....	24
9.4 DMA	25
9.5 Watchdog Extension.....	26
10. THE JIDA STANDARD.....	27
11. NETWORK OPERATION.....	30
11.1 Overview	30
11.2 Configuration 82559ER	30
11.3 Software and driver setup.....	31
11.4 Ethernet Technical Support.....	31
12. SPECIFICATIONS	32
12.1 Mechanical Specifications	32
12.2 Electrical Specifications	32
12.3 Environmental Specifications	32
13. PERIPHERAL INTERFACE	33
13.1 Keyboard, Reset, Battery, Speaker.....	33
13.2 Serial Port COM A, B RS232C	34
13.3 Parallel Port LPT 1	35
13.4 Floppy Connector	35
13.5 IDE Connector for 2,5" Hard Disk.....	36
13.6 Ethernet Connector	36
13.7 USB Connector.....	36
13.8 Power Connector	37
13.9 PC/104-Connector.....	38
14. LITERATURE, STANDARDS, LINKS.....	39
14.1 PC/104-Bus	39
14.2 ISA-Bus, Standard PS/2 - Connectors	39
14.3 RS232C	39

14.4	ATA	39
14.5	USB	39
14.6	PCI	39
15.	DOCUMENT REVISION HISTORY	40

2.0 USER INFORMATION

2.1 Trademarks

AT and IBM are trademarks of International Business Machines

XT, AT, PS/2 and Personal System/2 are trademarks of International Business Machines Corporation.

Microsoft is a registered trademark of Microsoft Corporation.

Intel is a registered trademark of Intel Corporation.

All other products and trademarks mentioned in this manual are trademarks of their respective owners.

The reproduction, transmission or use of this document or its contents is not permitted without expressed written authority.

Offenders will be liable for damages. All rights created by patent grant or registration of a utility model or design, are reserved.

2.2 General

For the circuits, descriptions and tables indicated no responsibility is assumed as far as patents or other rights of third parties are concerned.

The information in the Technical Descriptions describes the type of the boards and shall not be considered as assured characteristics.

The reproduction, transmission or use of this document or its contents is not permitted without express written authority. Offenders will be liable for damages. All rights, including rights created by patent grant or registration of a utility model or design, are reserved.

2.3 Warranty

Each board is tested carefully and thoroughly before being shipped. If, however, problems should occur during the operation, please check your user specific settings of all boards included in your system. This is often the source of the fault. If a board is defective, it can be sent to your supplier for repair. Please take care of the following steps:

1. The board returned should have the factory default settings since a test is only possible with these settings.
2. In order to repair your board as fast as possible we require some additional information from you. Please fill out the attached Repair Form and include it with the defective board.
3. If possible the board will be upgraded to the latest version without additional cost.
4. Upon receipt of the board please be aware that your user specific settings were changed during the test.

Within the warranty period the repair is free of charge as long as the warranty conditions are observed. Because of the high test expenditure you will be charged with the test cost if no fault is found. Repair after the warranty period will be charged.

This product is warranted against defects in material and workmanship for the warranty period from the date of shipment

2.4 Support, problems and failure analysis

It is not in the responsibility of GAI to supply you with informations about standard PC technology. Please find a selection of different information sources for your convenience in chapter [„Literature“](#)

Before contacting GAI please check first our web page for available information (newest manuals, application notes etc.). If you can't solve the problem on your own with this documents, do not hesitate to contact us by email or phone. Please prepare yourself to answer a few questions like

- which module(s) is(are) concerned?
- what serial numbers (xx??????)?
- what BIOS versions?
- since when is this problem known
- is this problem already reported (to whom?)
- and so on...

3. INTRODUCTION

The **3007632** integrates the complete functionality of a pentium motherboard with CPU, System- BIOS, up to 64 MByte SDRAM, keyboard-controller, real time clock and additional peripheral functions like COM1, COM2, LPT1, Floppy-interface, EIDE-harddisk-interface, watchdog and Ethernet access. The system runs with CPU clock speed 166MHz and 266 MHz.

4. FEATURES

- **Processor**
 - Intel Pentium® with 166 MHz internal Clock and 32 kByte write-back-Cache or
 - Intel Pentium® with 266 MHz internal Clock and 32 kByte write-back-Cache

- **Chipset**
 - ALI M1543C/M1531 PCI Chipset; extended temperature

- **Power Supply**
 - 5V only supply

- **Memory**
 - 32/64MB SDRAM-SODIMM-Module

- **Ethernet 100BaseT (Twisted Pair)**

- **Two serial ports, (COM1 and COM2)**
 - standard RS232C serial ports with FIFO, 16550 compatible

- **Parallel port, LPT1**
 - With ECP/EPP-support

- **Floppy-interface**

- **EIDE-PCI-hard disk-interface**
 - PCI Bus Master IDE port (up to 2 IDE Devices)
 - supports PIO Mode 3,4 IDE & ATAPI CD-ROM

- **Watchdog**

- **128 KByte FLASH-BIOS (Phoenix)**

- **Real Time Clock**
 - With external Battery-support

- **Keyboard Controller**

5. I/O MAP

The I/O-port addresses of the processor module **3007632** are functionally identical with a standard PC/AT.

I/O Addresses	3007632 - onboard	Function
0000 - 001F	X	DMA-Controller 1
0020 - 003F	X	Interrupt-Controller 1
0040 - 0043	X	Timer
0050 - 005F		Onboard Control Registers
0060 - 0064	X	Keyboard-controller
0061	X	Port B Register
0070	X	NMI Enable Register
0070 - 0071	X	Real Time Clock
0080 - 008F	X	DMA Page Register 74LS612
0092	X	Port A Register (Fast A20 Gate)
00A0 - 00BF	X	Interrupt-Controller 2
00C0 - 00DF	X	DMA-Controller 2
00F0 - 00FF	X	Math-Coprocessor
0100 - 10F	X	Onboard Control Registers
01F0 - 01F8	X	Fixed Disk
0200 - 0207		Game I/O
020C-020D		Reserved
021F		Reserved
0274		Control Register 1 External SSD (Board 0 - 3)
0275		Control Register 1 External SSD (Board 4 - 7)
0278 - 027F		Parallel Port 2
02B0 - 02DF		Alternate Enhanced Graphics Adapter
02E1		GPIB (adapter 0)
02E2 - 02E3		Data acquisition (Adapter 0)
02E8 - 02EF		Serial Port 4
02F8 - 02FF	X	Serial Port 2
0300 - 030F	X	Onboard Network (default configuration)
0310 - 031F		Prototype Card
0360 - 0363		PC Network (low Address)
0364 - 0367		Reserved
0368 - 036B		PC Network (high Address)
036C - 036F		Reserved
0370 - 0377		Config. Space for second SMC Controller
0378 - 037F	X	Parallel Port 1
0380 - 038F		SDLC, Bisynchronous 2
0390 - 0393		Cluster
03A0 - 03AF		Bisynchronous 1
03B0 - 03BF	X	Monochrom Disp. and Printer Adap.
03C0 - 03CF	X	Enhanced Graphic Adapter
03D0 - 03DF		Color/Graphic Monitor Adapter
03E8 - 03EF		Serial Port 3
03F0 - 03F7	X	Diskette Controller
03F8 - 03FF	X	Serial Port 1

6. BLOCK DIAGRAM

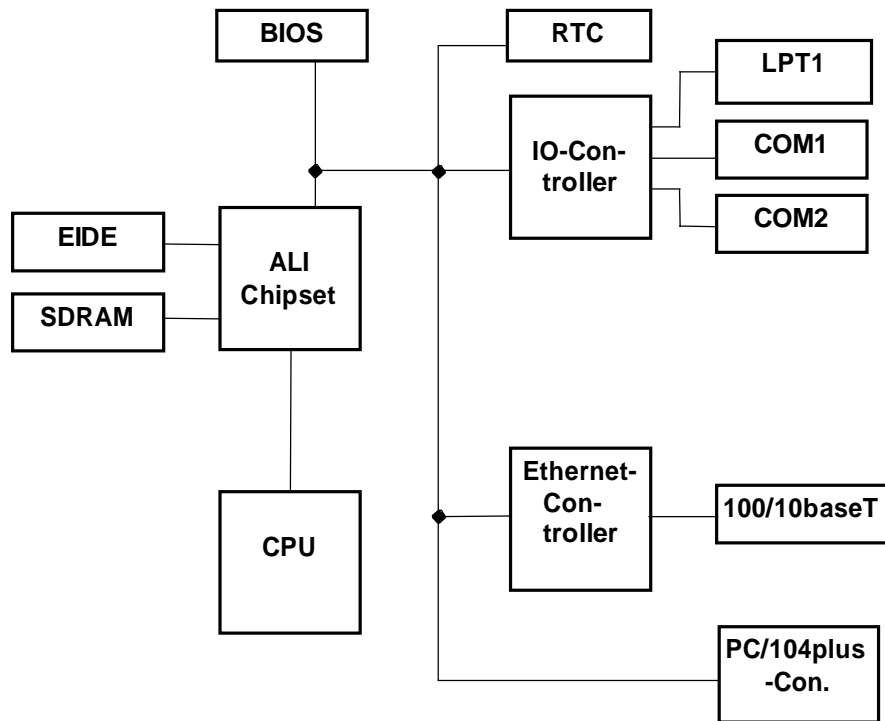

7. CONNECTOR ARRANGEMENT

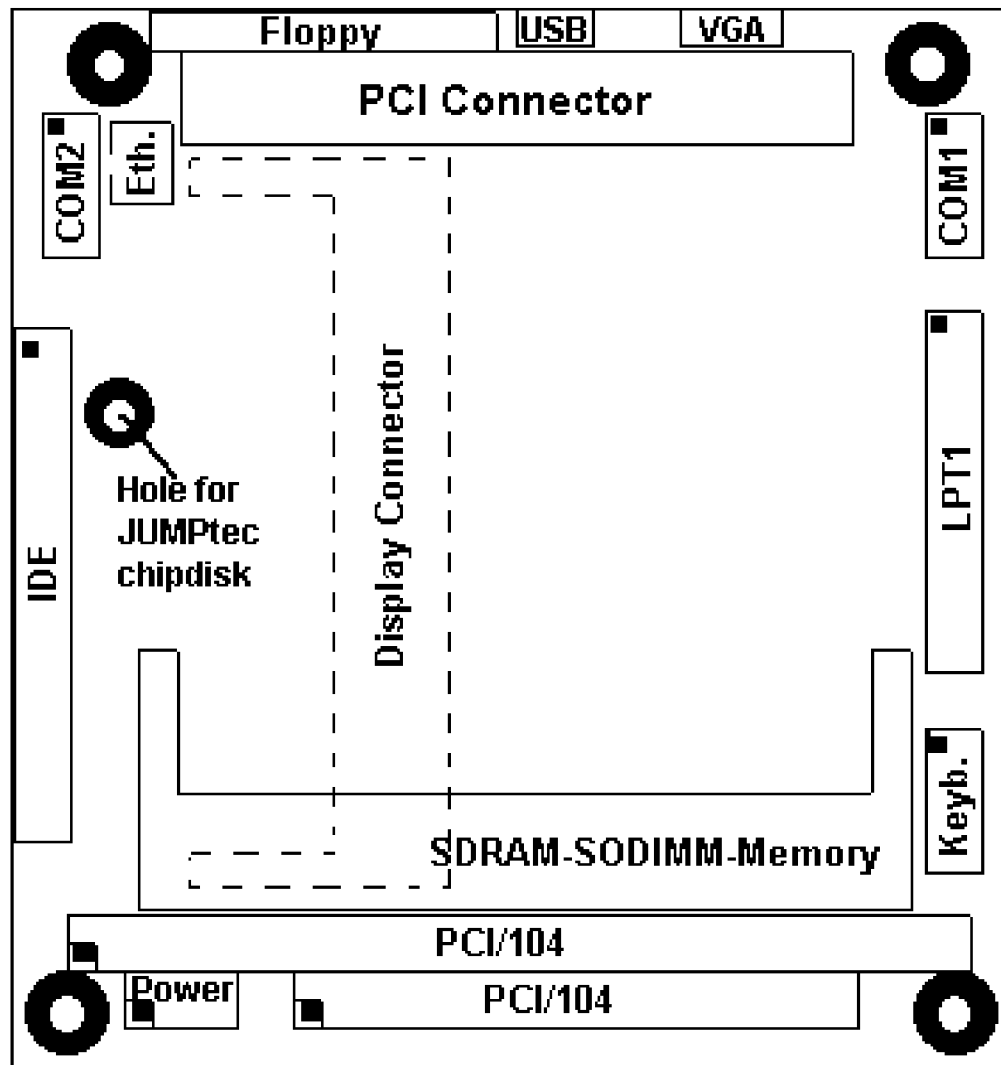

8. BIOS-DESCRIPTION

The **3007632** is equipped with a Phoenix BIOS which is located in a Flash EPROM onboard. This device has 8bit wide access. Faster access (16bit) is provided by the shadow RAM feature (default).

8.1 The Setup Guide

With the PhoenixBIOS Setup programm, you can modify BIOS settings and control the special features of the computer. The setup programm uses a number of menus for making changes and turning the special features on or off.

General Information

To start the PhoenixBIOS setup utility press <F2> when the string `Press <F2> to enter Setup` is displayed during bootup. The Main Menu will be displayed.

The Menu Bar

The Menu Bar at the top of the window lists all the different menus. Use the left/right arrows to make a selection.

The Legend Bar

Use the keys listed in the legend bar on the bottom to make your selection or exit the current menu. The table below describes the legend keys and their alternates:

Key	Function
<F1> or <Alt-H>	General help window
<Esc>	Exit this menu
← or → Arrow key	Select a different menu
↑ or ↓ Arrow key	Move cursor up and down
<Tap> or <Shift-Tap>	Cycle cursor up and down
<Home> or <End>	Move cursor to top or bottom of current window
<PgUp> or <PgDn>	Move cursor to next or previous page
<F5> or <->	Select the previous value for the current field
<F6> or <+> or <Space>	Select the next value for the current field
<F9>	Load default configuration values for this menu
<F10>	Save and Exit
<Enter>	Execute command or select submenu
<Alt-R>	Refresh screen

To select an item, simply use the arrow key to move the cursor to the field you want. Then use the plus and minus keys to select a value for that field. The Save Value commands in the Exit Menu save the values currently displayed in all the menus.

To display a sub menu, use the arrow keys to move the cursor to the sub menu you want. Then press <Enter>. A pointer (4) marks all sub menus.

The Field Help Window

The help window on the right side of each menu displays the help text for the currntly selected field. It updates as you move the cursor to each field.

The General Help Window

Pressing <F1> or <Alt-F1> on any menu brings up the General Help Window that describes the legend keys and their alternates. Press <Esc> to exit the General Help Window.

The Main Menu

You can make the following selections on the Main Menu itself. Use the sub menus for other selections.

Feature	Option	Description
System Time	HH:MM:SS	Set the system time. Use <Enter to move to MM or SS.
System Date	MM/DD/YYYY	Set the system date. . Use <Enter to move to DD or YYYY.
Legacy Diskette A	360 kB, 5 ¼ “ 1.2 MB, 5 ¼ “ 720 kB, 3 ½ “ 1.44/1.25 MB, 3 ½ “ 2.88 MB, 3 ½ “ Not Installed Disabled	Select the type of floppy disk drive installed in the system.
Legacy Diskette B	See above Disabled	See above
⊗ Primary Master	autodetected drive	Displays result of PM autotyping.
⊗ Primary Slave	autodetected drive	Displays result of PS autotyping.
⊗ Memory Shadow	sub menu	Opens Memory Shadow Menu
⊗ Memory Cache	sub menu	Opens Memory Cache Menu
System Memory	N/A	Displays amount of conventional memory detected during bootup.
Extended Memory	N/A	Displays amount of extendedmemory detected during bootup.

Selecting one of the Master or Slave sub menus displays a menu like this:

Feature	Option	Description
Type	None User Auto CD-ROM	None = Autotyping is not able to supply the drive type or end user has selected None, disabling any drive that may be installed. User = End user supplies the hdd information. Auto = Autotyping, the drive itself supplies the information. CD-RO = CD-ROM drive.
Cylinders	1 to 65,536	Number of cylinders.
Heads	1 to 256	Number of read/write heads.
Sectors	1 to 63	Number of sectors per track.
Maximum Capacity	N/A	Displays the calculated size of the drive
Multi-Sector Transfer	Disabled Standard 2 sectors 4 sectors 8 sectors 16 sectors	Any selection except Disabled determines the number of sectors transferred per block. Standard is 1 sector per block.
LBA Mode Control	Disabled Enabled	Enabling LBA causes Logical Block Addressing to be used in place of CHS.
32-Bit I/O	Disabled Enabled	Enables 32-bit communication between CPU and IDE card. Requires PCI or Local Bus.
Transfer Mode	Standard Fast PIO 1 Fast PIO 2 Fast PIO 3 Fast PIO 4	Selects the method for transferring the data between the hard disk and system memory.
SMART Device Monitoring	Disabled Enabled	Enables SMART warnings of imminent failure of drive.

Memory Shadow sub menu:

Feature	Option	Description
C800 - CBFF	Disabled Enabled	Accesses to this upper memory region go to the ISA bus if Disabled or to local memory if Enabled. NOTE: This option is not displayed if VGA BIOS exceeds 32kB! In that case this region is shadowed automatically.
CC00 - CFFF	Disabled Enabled	Accesses to this upper memory region go to the ISA bus if Disabled or to local memory if Enabled.
D000 – D3FF	Disabled Enabled	see above.
D400 – D7FF	Disabled Enabled	see above.
D800 - DBFF	Disabled Enabled	see above.
DC00 - DFFF	Disabled Enabled	see above.

Memory Cache sub menu:

Feature	Option	Description
System BIOS	Disabled Enabled	Caches the system BIOS to improve performance.
Video BIOS	Disabled Enabled	Caches the video BIOS to improve performance.
C800 - CBFF	Disabled Enabled	Controls caching of accesses to this upper memory region. NOTE: this option is not displayed if VGA BIOS exceeds 32k! In that case this region is handled by the option video BIOS.
CC00 - CFFF	Disabled Enabled	Controls caching of accesses to this upper memory region.
D000 – D3FF	Disabled Enabled	see above.
D400 – D7FF	Disabled Enabled	see above.
D800 - DBFF	Disabled Enabled	see above.
DC00 - DFFF	Disabled Enabled	see above.

The Advanced Menu

Selecting „Advanced“ from the menu bar displays this menu:

Feature	Option	Description
⌘ Advanced Chipset Control	sub menu	Opens Advanced Chipset Control sub menu.
Plug & Play OS	Yes No	If your system has a PNP OS (e.g. Win95) select Yes to let the OS configure PNP devices not required for boot. No makes the BIOS configure them.
Secured Setup Configuration**	Yes No	Yes prevents a Plug and Play OS from changing system settings.
Reset Configuration Data	No Yes	Yes erases all configuration data in ESCD, which stores the configuration settings for plug-in devices. Select Yes when required to restore the manufacturer's defaults.
⌘ PCI Configuration	sub menu	Opens PCI Advanced sub menu.
⌘ Keyboard Features	sub menu	Opens Keyboard Features sub menu.
⌘ I/O Device Configuration	sub menu	Opens I/O Device Configuration sub menu.
Large Disk Access Mode	DOS Other	Select DOS if you have DOS. Select Other if you have another OS such as UNIX. A large disk is one that has more than 1024 cylinders, more than 16 heads or more than 63 sectors per track.
Halt On Errors*	Yes No	Determines if post errors cause the system to halt.

*) P588R113 upwards, **) P588R116 upwards

Advanced Chipset Control sub menu:

Feature	Option	Description
AT bus clock frequency	7.16 MHZ PCICLK/4 PCICLK/3	Allows to select ISA bus clock frequency. NOTE: Some ISA devices might not work at PCICLK/3 (11 MHz)!
Passive Release	Disabled Enabled	Enables more efficient ISA Bus master cycles to PCI.
Delayed Transaction	Disabled Enabled	Latches PCI-to-ISA cycles into buffer to free the PCI bus.
ISA Master Line Buffer	Disabled Enabled	Enables ISA master line buffer to enhance performance.
DMA Line Buffer	Disabled Enabled	Enables DMA line buffer to enhance performance.
PCI to ISA Posted Write Buffer	Disabled Enabled	Enables PCI to ISA posted write buffer.
Enable Memory Gap **	Disabled Conventional Extended	Turns system RAM of and frees address space (512kB-640kB or 15MB-16MB) for use with an option card.
CAS Latency	2 3	Select CAS Latency time.
SDRAM Timing *	3-6-9 3-5-8 3-4-7 2-5-7	Controls RAS pre-charge timing in HCLKIN 5. tRP – tRAS – tRC
Pipe Function	Disabled Enabled	Enables the asserting of NA (Next Address) when the cycle is a L2 or DRAM access cycle.
Primary Frame Buffer	Disable, 1 MB, 2 MB , 4 MB, 8 MB, 16 MB	Select the size of the primary frame buffer and enables Host to PCI write buffer
VGA Frame Buffer	Disabled Enabled	Enables burst PCI cycles for VGA fixed frame buffer at A0000h – BFFFFh.
Data Merge	Disabled Enabled	If enabled, only the words which address are consecutive linear can be merged into one line.
Byte Merge	Disabled Enabled	Enables the byte-merge feature for frame buffer cycles
Fast Back to Back	Disabled Enabled	Enables PCI fast back to back capability.
PCI Write Burst	Disabled Enabled	Enables PCI write burst capability.

*) default changed for P588R115 (was 3-4-7), **) P588R116 upwards

PCI Configuration sub menu:

Feature	Option	Description
⊗ PCI Device, Slot #1	sub menu	Opens sub menu to configure slot 1 PCI device
⊗ PCI Device, Slot #2	sub menu	Opens sub menu to configure slot 2 PCI device
⊗ PCI Device, Slot #3	sub menu	Opens sub menu to configure slot 3 PCI device
⊗ PCI Device, Slot #4	sub menu	Opens sub menu to configure slot 4 PCI device
PCI IRQ line 1	Disabled Auto IRQ3, 4, 5, 7, 9, 10, 11, 12, 14,15	Select IRQ for PIC interrupt INTA. Select Auto to let the BIOS assign the IRQ.
PCI IRQ line 2	see above	Select IRQ for PIC interrupt INTB. Select Auto to let the BIOS assign the IRQ.
PCI IRQ line 3	see above	Select IRQ for PIC interrupt INTC. Select Auto to let the BIOS assign the IRQ.
PCI IRQ line 4	see above	Select IRQ for PIC interrupt INTD. Select Auto to let the BIOS assign the IRQ.
USB IRQ line*	see above	Select IRQ for embedded USB device. Select Auto to let the BIOS assign the IRQ.
⊗ PCI/PNP ISA UMB Region Exclusion	sub menu	Opens UMB Region Exclusion sub menu.
⊗ PCI/PNP ISA IRQ Resource Exclusion	sub menu	Opens IRQ Exclusion sub menu.
ISA graphics device installed	No Yes	PCI devices may need to know if an ISA graphics device is installed in the system in order to enable that card to function correctly
Assign IRQ to PCI VGA	Yes No	Actually the onboard vga does not need an IRQ assigned, but Win98 2 nd Edition doesn't work correctly if no IRQ is assigned

*) P588R113 upwards

NOTE: Use IRQ Miniport driver for ALI M1543C south bridge (download from www.ali.com.tw) on Systems running Win95!

PCI Device, Slot #X sub menu:

Feature	Option	Description
Option ROM Scan	Disabled Enabled	Initialize device expansion ROM
Enable Master	Disabled Enabled	Enables device in slot as a PCI bus master. Not every device can function as a master. Check your device documentation.
Latency Timer	20h, 40h , 60h, 80h, A0h, C0h, E0h	Minimum guaranteed time slice allocated for bus master in units of PCI bus clocks. A high-priority, high-throughput device may benefit from a greater value.

PCI/PNP ISA UMB Region Exclusion sub menu:

Feature	Option	Description
C800 - CBFF	Available Reserved	Reserves the specified block of upper memory for use by legacy ISA devices.
CC00 - CFFF	see above	see above
D000 – D3FF	see above	see above
D400 – D7FF	see above	see above
D800 - DBFF	see above	see above
DC00 - DFFF	see above	see above

PCI/PNP ISA IRQ Exclusion sub menu:

Feature	Option	Description
IRQ3	Available Reserved	Reserves the specified IRQ for use by legacy ISA devices.
IRQ4	see above	see above
IRQ5	see above	see above
IRQ7	see above	see above
IRQ9	see above	see above
IRQ10	see above	see above
IRQ11	see above	see above
IRQ12 *	see above	see above
IRQ14 * (only visible if IDE disabled)	see above	see above
IRQ15	see above	see above

*) P588R116 upwards

Keyboard Features sub menu:

Feature	Option	Description
Numlock	Auto On Off	On or Off turns NumLock on or off at bootup. Auto turns NumLock on if it finds a numeric key pad.
Key Click	Disabled Enabled	Turns audible key click on.
Keyboard auto-repeat rate	30/sec , 26.7/sec, 21.8/sec, 13.3/sec, 10/sec, 6/sec, 2/sec	Sets the number of times to repeat a keystroke per second if you hold the key down.
Keyboard auto-repeat delay	¼ sec, ½ sec , ¾ sec, 1 sec	Sets the delay time after the key is held down before it begins to repeat the keystroke.

I/O Device Configuration sub menu:

Feature	Option	Description
Local Bus IDE adapter	Disabled Enabled	Enables onboard PCI IDE device.
Floppy disk controller	Disabled Enabled	Enables onboard FDC controller.
Base I/O address	Primary Secondary	Selects base address of onboard FDC controller. (Primary = 3F0h, Secondary = 370)
Serial port A Serial port B	Disabled Enabled Auto OS Controlled	Disabled turns off the port. Enabled requires end user to enter the base I/O address and the IRQ. Auto makes the BIOS configure the port. OS Controlled lets the PNP OS configure the port after bootup.
Base I/O address	3F8h, 2F8h, 3E8h, 2E8h	Select I/O base of port.
IRQ (port A and B)	IRQ 3, IRQ 4	Select IRQ of port A and B
Parallel Port	Disabled Enabled Auto OS Controlled	Disabled turns off the port. Enabled requires end user to enter the base I/O address and the IRQ. Auto makes the BIOS configure the port. OS Controlled lets the PNP OS configure the port after bootup.
Mode	Output only Bi-directional ECP EPP	Set the mode for the parallel port.
Base I/O address	378h, 278h, 3BCh	Select I/O base of port.
IRQ	IRQ 5, IRQ 7	Select IRQ of parallel port.
DMA	DMA0, 1, 2, 3	Select DMA channel of port if in ECP mode.
USB Host Controller	Disabled Enabled	Enable or Disable onboard USB controller.
USB BIOS Legacy Support*	Disabled Enabled	Enable or Disable support for USB keyboard and mice. Enable for use with non-USB aware OSes such as UNIX and DOS.
⌘ Watchdog Settings	sub menu	Opens Watchdog Settings sub menu

***) NOTE: If USB legacy support is enabled, IRQ12 is used by the usb ohci controller. If you run a system with win9x and without a mouse attached, set irq12 to reserved in the PCI/PNP ISA IRQ Exclusion sub menu to prevent win9x from allocating irq12 for pci devices!**

Watchdog Settings sub menu:

Feature	Option	Description
Mode	Disabled Reset NMI	Select watchdog operation mode.
Delay	1s, 5s, 10s, 30s , 1min, 5min, 10min, 30min	The time until the watchdog counter starts counting. Useful to handle longer boot times. Max. trigger periode.
Timeout	0.4s, 1s, 5s, 10s, 30s , 1min, 5min, 10min	

The Security Menu

Selecting „Security“ from the menu bar displays this menu:

Feature	Option	Description
Set User Password	Up to seven alphanumeric characters	Pressing <Enter> displays the dialog box for entering the user password. In related systems, this password gives restricted access to setup. Pressing <Enter> displays the dialog box for
Set Supervisor Passord	Up to seven alphanumeric characters	entering the user password. In related systems, this password gives full access to setup. Enabled requires a password on boot.
Password on boot	Disabled Enabled	Requires prior setting of the supervisor password. If supervisor password is set and this option is disabed, BIOS assumes user is booting. Enabled requires supervisor password to
Diskette access	User Supervisor	access floppy disk.
Fixed disk boot sector	Normal Write protected	Write protect the boot sector on the hard disk for virus protection. Requires a password to format or Fdisk the hard disk.
Virus check reminder System backup reminder	Disabled Daily Weekly Monthly	Displays a message during bootup asking (Y/N) if you backed up the system or scanned for viruses. Message returns on each boot until you respond with „Y“: Daily displays the message on the first boot of the day, Weekly on the first boot after Sunday, and Monthly on the first boot of the month.

Enabling „Supervisor Password“ requires a password for entering Setup.
The passwords are **not case sensitive!**

Note: User and Supervisor passwords are related! You cannot have a User password without first creating a Supervisor password.

The Power Menu

A power management system reduces the amount of energy used after specified periods of inactivity. The setup menu supports a **Full On** state, a **Standby** state with partial power reduction, and a **Suspend** state with full power reduction.

Use the Advanced Options sub menu to specify whether or not an activity can terminate a Standby or Suspend state and restore Full On.

Selecting „Power“ from the menu bar displays this menu:

Feature	Option	Description
Power Savings	Disabled Customized Maximum Power Saving Maximum Performance	Maximum options select predefined values. Select Customized to make your own selections from the following fields. Disabled turns off all power management.
Standby Timeout	Off , 1min, 2min, 4min, 6min, 8min, 12min, 16min	Inactivity period required to put system in Standby mode (partial power shutdown).
Auto Suspend Timeout	Off , 5min, 10min, 15min, 20min, 30min, 40min, 60min	Inactivity period required after Standby to Suspend mode (maximum power shutdown).
Hard Disk Timeout	Disabled , 10 sec – 15 min	Inactivity period of hard disk required before standby (motor off).
⊗ Advanced Options	sub menu	Opens advanced options sub menu

LCD Backlight Off Timer	Disabled , 28 sec – 14 min	If enabled, backlight is switched off after the selected period of time without video activity
-------------------------	-----------------------------------	------------------------------------------------------------------------------------------------

Advanced Options sub menu:

Feature	Option	Description
Video I/O	Yes No	Wakes up system on video event
Primary HDD	Yes No	Wakes up system on primary HDD event.
Floppy Disk Drive	Yes No	Wakes up system on FDD event.
Serial I/O	Yes No	Wakes up system on serial I/O event.
Parallel I/O	Yes No	Wakes up system on parallel I/O event.
Keyboard	Yes No	Wakes up system on keyboard event.
RTC	Yes No	Wakes up system on RTC alarm.

monitored events:

Video I/O	3B0h – 3DF I/O and A/B segment memory
Primary HDD	1F0h – 1F7h and 3F6h I/O access, primary IDE channel DMA request
Secondary HDD	170h – 177h and 376h I/O access, secondary IDE channel DMA request
FDD	3F0h – 3F7h I/O access
Serial I/O	3F8h – 3FFh, 2F8h – 2FFh, 3E8h – 3EFh, 2E8h – 2EFh, 338h – 33Fh, 238h – 23Fh
Parallel I/O	378h – 37Fh, 278h – 27Fh, 3BCh – 3BEh
Keyboard	60h and 64h I/O access

Besides the events explained above the following events will wake the system from suspend state:

- IRQ[1-7], IRQ[9-15], NMI, SMI, INIT
- RTC IRQ 8

The Boot Menu

See chapter „Boot Utilities“below

The Exit Menu

The following sections describe the five possible options of the Exit Menu. Note that <Esc> does not exit this menu. You must select one of the items from the menu to exit.

Exit Saving Changes

Saves all the selections and exits setup. The next time you boots, the BIOS configures the system according to the Setup selection stored in CMOS.

Exit Discarding Changes

Use this option to exit Setup without storing in CMOS any new selections you may have made. The selections previously in effect remain in effect.

Load Setup Defaults

Select to display the default values for all the Setup menus.

Discard Changes

If, during a Setup session, you change your mind about changes you have made and have not yet saved the values to CMOS, you can restore the values you previously saved to CMOS.

Save Changes

Saves all the selection without exiting Setup. You can return to the other menus if you want to review and change your selection.

8.2 Boot Utilities

QuietBoot

Right after you turn on or reset the computer, Quietboot displays a graphical logo instead of the text based POST screen, which displays a number of PC diagnostic messages.

The graphical logo stays up until just before the OS loads unless:

- § You press <Esc> to display the POST screen
- § You press <F2> to enter Setup
- § POST issues an error message
- § The BIOS or an option ROM requests keyboard input

MultiBoot

MultiBoot expands your boot options by letting you choose your boot device, which could be a hard disk, floppy disk, CD-ROM or network card. You can select your boot device in Setup, or you can choose a different device each time you boot by selecting your boot device in **The Boot First Menu**.

MultiBoot consists of 4 menus:

The Setup Boot Menu

Feature	Option	Description
Floppy Check	Disabled Enabled	Enabled verifies floppy type on boot; disabled speeds boot.
Summary Screen	Disabled Enabled	If enabled, a summary screen is displayed just before booting the OS to let the end user see the system configuration.
QuickBoot Mode	Disabled Enabled	Allows the system to skip certain tests while booting. This will decrease the time needed to boot the system.
Dark Boot	Disabled Enabled	If enabled, system comes up with a blank screen instead of the diagnostic screen during bootup.
⌘ Boot Device Priority	sub menu	Opens boot device priority sub menu
Onboard LAN RPL ROM *	Disabled Enabled	Enables Remote Program Load ROM of the onboard LAN controller. Supports Intel PXE. See www.support.intel.com/support/desktopmgmt/pxepdk.htm for more information

*) P588R116 upwards

The Boot Device Priority Menu

This menu allows to select the order of the devices from which the BIOS attempts to boot the OS. During POST, if BIOS is unsuccessful at booting from one device, it will try the next one on the list. The items on this menu each may represent the first of a class of items. For example, if you have more than one hard disk drive, Hard Drive represents the first of such drives as specified in the Hard Drive menu described below.

To change the order select the device you want to change and press <-> to decrease or <+> to increase priority.

Feature	Option	Description
---------	--------	-------------

⊗ Removable Devices	boot priority & sub menu	Sets boot priority of Removable Devices as described in the respective sub menu.
⊗ Hard Drives	boot priority & sub menu	Sets boot priority of Hard Disks as described in the respective sub menu.
ATAPI CD-ROM Drive	boot priority	Sets boot priority of ATAPI CD:ROM Drives.
⊗ Network Boot	boot priority & sub menu	Sets boot priority of Network Adapters as described in the respective sub menu.

The Removable Devices Menu

If you have more than one Removable Media drive, select Removable Devices and press <Enter> to display the Removable Media menu and choose which drive is represented in boot-order menu. Note: The standard 1.44MB floppy drive is referenced as „Legacy Floppy Drives“:

The Hard Drive Priority Menu

If you have more than one bootable hard drive, select Hard Drive and press <Enter> to display the Fixed Disk Menu and choose the boot priority.

The Network Boot Priority Menu

If you have more than one bootable network adapter in the system, select Network Boot and press <Enter> to display the available network adapters and choose the boot priority.

The Boot First Menu

Display the Boot First Menu by pressing <Esc> during POST. In response, the BIOS first displays the message „Entering Boot Menu...“and then displays the Boot Menu at the end of POST.

Use the menu to select any of these options:

- § Override the existing boot sequence (for this boot only) by selecting another boot device. If the specified device does not load the OS, the BIOS reverts to the previous boot sequence.
- § Enter Setup
- § Press <Esc> to continue with the existing boot sequence.

8.3 BIOS Update with Phoenix Phlash

Phoenix Phlash gives you the ability to update your BIOS from a floppy disk without having to install a new ROM chip. Phoenix Phlash is a utility for „flashing“a BIOS to the Flash ROM installed on the **3007632**.

Use Phoenix Phlash for the following tasks only:

- Update the current BIOS with a newer version
- Restore a BIOS when it has become corrupted (see below)

To create the Crisis Recovery Diskette insert a clean diskette into drive A: or B: and execute WINCRISIS.EXE. This copies four files onto the Crisis Recovery Diskette:

MINIDOS.SYS	Allows the system to boot in Crisis Recovery Mode
PHLASH.EXE	Programs the flash ROM
PLATFORM.BIN	Performs platform-dependent functions
BIOS.ROM	Actual BIOS image to be programmed into flash ROM

If the BIOS image (BIOS.ROM) changes due to an update or bug fix, you can easily update the Crisis Recovery Disk. Simply copy the new BIOS.ROM image onto the diskette.

You can run Phoenix Phlash in one of two modes:

- Command Line Mode
- Crisis Recovery Mode

Use the Command Line mode to update or replace your current BIOS. To execute Phlash in this mode, move to the Crisis Recovery Disk and type PHLASH. Phoenix Phlash will automatically update the BIOS. Phlash may fail if your system is using memory managers, in which case the utility will display the following message:

```
Cannot flash when memory manager are present.
```

If you see this message after you execute Phlash, you must disable the memory manager on your system!

8.4 Boot Block Support

Updating the BIOS may create a possible hazard: power failures or fluctuations that occur during updating the Flash ROM can damage the BIOS code, making the system unbootable.

To prevent this possible hazard the **3007632** is equipped with a boot block Flash ROM. The boot block region contains a fail-safe recovery routine. If the boot block code finds a corrupted BIOS (checksum fails), it boots into the crisis recovery mode and loads a BIOS image from a special crisis diskette (see above).

Additionally the end user can insert an update key into the parallel port to force initiating the boot block recovery routine.

For further information on the update key and the crisis diskette, visit www.globalamericaninc.com.

9. HARDWARE DESCRIPTION

9.1 ALI-Chipset Features

The **3007632** Board operates with the chipset ALI Aladdin IVPlus, which provides following features:

North bridge M1531:

- Supports SDRAM DRAMs
- Fully synchronous 33Mhz 3.3V/5V tolerance PCI interface
- Enhanced power management

South bridge M1543C:

- PCI 3.3V/5V tolerance interface
- Buffers control
- Provides steerable PCI interrupts for PCI device Plug-and-Play
- Enhanced DMA controller
- Interrupt controller
- Counters/timers
- Distributed DMA supported
- Serialized IRQ supported
- Plug-and-Play supported
- Built-in keyboard controller
- Supports positive/subtractive decode for ISA device
- PMU features
- Built-in PCI IDE controller
- USB interface
- Super I/O interface

9.2 Memory configuration

The **3007632** uses only small outline Dual Inline Memory Modules (SO-DIMMs). One socket is available for 3.3 Volt (power level) unbuffered Synchronous Dynamic Random Access Memory (SDRAM) of either 32 or 64MB.

9.3 Interrupts

IRQ0	System Timer	
IRQ1	Keyboard	
IRQ2	Cascade	
IRQ3	COM 2	note (1)
IRQ4	COM 1	note (1)
IRQ5	Available	
IRQ6	Floppy	
IRQ7	LPT 1	
IRQ8	Clock/Calendar	
IRQ9	Available	
IRQ10	Available	
IRQ11	Available	
IRQ12	Available	
IRQ13	Numeric-processor	
IRQ14	EIDE Channel 1	
IRQ15	Available	

Notes:

(1) if serial ports are disabled via system bios, these interrupts are available for other devices.

9.4 DMA

DMA 0	Available
DMA 1	Available
DMA 2	Floppy
DMA 3	Available
DMA 4	Cascade
DMA 5	Available
DMA 6	Available
DMA 7	Available

9.5 Watchdog Extension

With the aid of a special Interrupt 15h function, the watchdog on a board can be controlled very easily.

The respective functions have the following calling conventions:

Watchdog init	Int 15h	00h
Input:	AH = E0h AL = 00h BX = timeout in 0.2sec increments CX = delay in 0.2sec increments DX = watchdog action (0 = reset, 1 = NMI)	
Output:	None	
Description:	This function is a public INT15h extension used to init the watchdog on boards.	

Watchdog trigger	Int 15h	01h
Input:	AH = E0h AL = 01h	
Output:	None	
Description:	This function is a public INT15h extension used to trigger the watchdog on boards.	

Detailed description of the watchdog function:

Programming:

The function *Init watchdog* must be called only once. The three parameters *delay time*, *timeout time* and *trigger event* must be set. After initialisation the watchdog will be active only after the delay time has expired. The watchdog must be reset during the *timeout time* with the *trigger watchdog function*. Otherwise a RESET or NMI will occur depending on *trigger event*.

The trigger- and the delay time can be set in steps of 0.2 sec.

The maximum values are:

 ȳ timeout time 65535*0.2sec. = 13107s \cong 3h 38min

 ȳ delay time 32767*0.2sec. = 6553s \cong 1h 49min

The system BIOS makes it very easy to use the watchdog via software interrupt 15h. Two ways are possible to access the watchdog: The simplest way is to use AH=0E0h to init or trigger the watchdog. The second way is to use the functions "Write I²C" and "Read I²C" with AH=0E1h and handling the I²C bus protocol.

A) Simple with AH = E0h

Init Watchdog (Int 15h, AH=E0h)

Called with	AX	E000h	
	BX	timeout time	
		BX = 0 $\bar{\circ}$ watchdog off. BX _{max} = 0FFFFh	
	CX	delay time	
		CX = 0 $\bar{\circ}$ no delay. CX _{max} = 07FFFh	
	DX	trigger event	
		DX = 0 $\bar{\circ}$ RESET, DX = 1 $\bar{\circ}$ IOCHCHK	
Returns		no	
Example			
	mov	ax,0E000h	; Watchdog set
	mov	bx,5	; 5*0,2s = 1s Timeout
	mov	cx,5	; 5*0,2s = 1s Delay
	mov	dx,0	; after Timeout and Delay generate RESET
	int	15h	

10. THE JIDA STANDARD

JIDA is the abbreviation for **JIDA** Intelligent Device Architecture.

Every board with onboard BIOS extension shall support the following function calls, which supply information about the board. JIDA functions are called via Interrupt 15h with AH=EAh, AL=function number, DX=4648h (security word), CL=board number (starting with 1).

The interrupt will return with CL#0, if a board with the number specified in CL does not exist. CL will be equal to 0 if the board number exists. In this case, the content of DX is used to determine, if operation was successful. DX=6B6Fh indicates successful operation, any other value indicates an error.

To get information about the installed boards following the JIDA standard, the following procedure is recommended:

Call "Get Device ID" with CL=1. The name of the first device installed will be returned. If result was "Board exists" (CL=0), increment CL and call "Get Device ID" again. Repeat until result is "Board not present" (CL#0). You now know the names of all boards within your system that follow the JIDA standard. More information about a specific board may then be obtained by calling the appropriate inquiry function with the board's number in CL.

WARNING: Association between board and board number may change due to configuration changes. Do **not rely on any association between board and board number**. Instead, always use the procedure described in the preceding paragraph first, to determine the association between board and board number.

Get Manufacturer ID	Int 15h
Input:	AX = EA00h CL = Board number (1=first board a.s.o.) ES:BX = Pointer to destination data area DX = 4648h
Output:	CL=0: Board present CL#0: Board not present DX=6B6Fh: Function successful DX#6B6Fh: Error
Description:	If CL=0 and DX=6B6Fh, then 4 Byte manufacturer ID were copied to the area pointed to by ES:BX By default, the result will be "JUMP". Note: There is no ending zero byte. Function must be implemented on every device supporting the JIDA.

Get Device ID	Int 15h
Input:	AX = EA01h CL = Board number ES:BX = Pointer to destination data area DX = 4648h
Output:	CL=0: Board present CL#0: Board not present DX=6B6Fh: Function successful DX#6B6Fh: Error
Description:	If CL=0 and DX=6B6Fh, then 7 Byte device ID were copied to area pointed to by ES:BX By default, the result will be "" Note: There is no ending zero byte. Function must be implemented on every device supporting the JIDA.

Get Manufacturing Date		Int 15h
Input:	AX = EA02h CL = Board number	DX = 4648h
Output:	CL=0: Board present CL≠0: Board not present BX = Manufacturing date	DX=6B6Fh: Function successful DX≠6B6Fh: Fn.not implemented
Description	If CL=0 and DX=6B6Fh, then BX=Manufacturing date. Date format is the same as used for DOS files: Bit0..4: Day Bit5..8: Month Bit9..15: Years since 1980	
Get Serial Number		Int 15h
Input:	AX = EA03h CL = Board number ES:BX = Pointer to destination data area	DX = 4648h
Output:	CL=0: Board present CL≠0: Board not present	DX=6B6Fh: Function successful DX≠6B6Fh: Fn.not implemented
Description:	If CL=0 and DX=6B6Fh, then 10 Byte serial number were copied to area pointed to by ES:BX The result is different for each single P588 . Note: There is no ending zero byte.	
Get Hardware Revision		Int 15h
Input:	AX = EA04h CL = Board number	DX = 4648h
Output:	CL=0: Board present CL≠0: Board not present BH=Major revision number BL=Minor revision number	DX=6B6Fh: Function successful DX≠6B6Fh: Fn.not implemented
Get Firmware Revision		Int 15h
Input:	AX = EA05h CL = Board number	DX = 4648h
Output:	CL=0: Board present CL≠0: Board not present BH=Major revision number BL=Minor revision number	DX=6B6Fh: Function successful DX≠6B6Fh: Fn.not implemented
Get Last Repair Date		Int 15h
Input:	AX = EA06h CL = Board number	DX = 4648h
Output:	CL=0: Board present CL≠0: Board not present BX = Last repair date.	DX=6B6Fh: Function successful DX≠6B6Fh: Fn.not implemented
Description:	If CL=0 and DX=6B6Fh, then BX=Last repair date. For date format see function "Get Manufacturing Date". If board was never repaired, result will be equal to manufacturing date.	

Read Running Time Meter		Int 15h
Input:	AX = EA07h CL = Board number	DX = 4648h
Output:	CL=0: Board present CL≠0: Board not present BX=Running time (hours) CH=Overflow counter	DX=6B6Fh: Function successful DX≠6B6Fh: Fn.not implemented
ReadBoot Counter		Int 15h
Input:	AX = EA08h CL = Board number	DX = 4648h
Output:	CL=0: Board present CL≠0: Board not present BX = Boot counter	DX=6B6Fh: Function successful DX≠6B6Fh: Fn.not implemented
Get JIDA Revision Level		Int 15h
Input:	AX = EA09h CL = Board number	DX = 4648h
Output:	CL=0: Board present CL≠0: Board not present BH = Major revision number BL = Minor revision number	DX=6B6Fh: Function successful DX≠6B6Fh: Fn. not implemented
Read User Byte from EEPROM		Int 15h
Input:	AX = EA40h CL = Board number BH = Number of byte to read (0..15 allowed)	DX = 4648h
Output:	CL=0: Board present CL≠0: Board not present BL = Value read	DX=6B6Fh: Function successful DX≠6B6Fh: Fn.not implemented
Write User Byte to EEPROM		Int 15h
Input:	AX = EA41h CL = Board number BH = Number of byte to write (0..15 allowed) BL = Value to write	DX = 4648h
Output:	CL=0: Board present CL≠0: Board not present	DX=6B6Fh: Function successful DX≠6B6Fh: Fn.not implemented
Get Number of User Bytes available in EEPROM		Int 15h
Input:	AX = EA42h CL = Board number	DX = 4648h
Output:	CL=0: Board present CL≠0: Board not present BL=Number of Bytes available Note: BL=0 means 256 Bytes	DX=6B6Fh: Function successful DX≠6B6Fh: Fn.not implemented

11. NETWORK OPERATION

11.1 Overview

The Ethernet interface on **3007632** is realized with the 82559ER from Intel®, a fully integrated 10BASE-T/100BASE-TX LAN solution. The 82559ER consists of both the Media Access Controller (MAC) and the physical layer (PHY) interface combined into a single component solution. The 32-bit PCI controller provides enhanced scatter-gather bus mastering capabilities and enables the 82559ER to perform high speed data transfers over the PCI bus. Two large transmit and receive FIFOs of 3 Kbyte each help prevent data underruns and overruns while waiting for bus accesses. The 82559ER can operate in either full duplex or half duplex mode. In full duplex mode the 82559ER adheres with the IEEE 802.3x Flow Control specification. Half duplex performance is enhanced by a proprietary collision reduction mechanism. The 82559ER also includes an interface to a serial (4-pin) EEPROM. The EEPROM provides power-on initialization for hardware and software configuration parameters.

The 82559ER provides following features:

- Integrated IEEE 802.3 10BASE-T and 100BASE-TX compatible PHY
- Glueless 32-bit PCI master interface
- Improved dynamic transmit chaining with multiple priorities transmit queues
- Backward compatible software to the 82558 and 82557
- Full Duplex support at both 10 and 100Mbps
- IEEE 802.3u Auto-Negotiation support
- 3 Kbyte transmit and 3 Kbyte receive FIFOs
- Fast back-to-back transmission support with minimum interframe spacing
- IEEE 802.3x 100BASE-TX Flow Control support
- Adaptive Technology
- TCP/UDP checksum offload capabilities
- Low power 3.3 V device
- Clockrun protocol support

11.2 Configuration 82559ER

Perform the following steps to configure your 82559ER PCI Ethernet Adapter:

1. Connect your network cable

The cable must be connected before loading the setup tool. To check the adapter's configuration run the 82559ER DOS setup utility, named setup.exe, included in the driver archive.

The setup utility shows the adapters configuration:

Adaper type:	Currently selected adapter.
Adapter part number:	Part number of the adapter.
Network address:	Node (MAC) address of adapter in hexadecimal.
Interrupt:	The interrupt the PCI BIOS assigned to the adapter.
Bus:	PCI bus number slot ID of the adapter.
Slot:	Slot number used for the adapter drivers.
Device:	Device number assigned by the PCI BIOS.
Network speed:	Speed of the current network link. Physical
layer device:	Actice physical layer device.
Duplex:	Current duplex setting.
Adapter capabilities:	Link type supported by this adapter.

2. Perform diagnostic tests „Test adapter“in main menu if needed.

11.3 Software and driver setup

Please refer to the corresponding readme and setup/install files.

11.4 Ethernet Technical Support

Many problems can be solved with the latest drivers for the 82559ER controller. **GAI** provides you with the latest *tested* drivers, which might be quite different from the newest ones. Therefore feel free to contact the Intel® web page for driver updates.

For further technical support, contact either **visit** www.globalamericaninc.com.

Intel World Wide Web server

Support: <http://support.intel.com>

Intel News: news://cs.intel.com

Corporate: <http://www.intel.com>

Intel FTP server download.intel.com

Navigate to this directory:

`/support/etherexpress`

Before contacting **GAI** for technical support, be prepared to provide as much of the following information as possible.

- 1) Adapter type
- 2) Adapter configuration
- 3) - I/O Base, Memory Base, I/O or memory mode enabled, IRQ, and DMA channel
- Configured for media auto-detect or specific media type (which type).
(Record this information from the driver's sign-on message if possible.)
- 4) Computer System's Configuration
- BIOS (make and version)
- System make and model
- CPU (type and speed)
- System RAM
- 5) Software
- 82559ER driver and version
- Your network operating system and version
- Your system's OS make/version (MS-DOS, Novell's DOS, Win95, WFWG, etc.)
- Version of all protocol support files
- Frame types supported by you server
- 6) Contents of your configuration files
- CONFIG.SYS
- AUTOEXEC.BAT
- PROTOCOL.INI
- NET.CFG FILE
- WINDOW'S SYSTEM.INI (if using Windows client)
- AUTOEXEC.NCF file
- or similar
- 7) Any Error Message displayed.

12. SPECIFICATIONS

12.1 Mechanical Specifications

PC/104 Bus connector: 2 pieces of 2*32 pin male and 2*20 pin male connector
 PC/104plus connector 4*30 pin 2mm connector

REMEMBER: The PC/104plus connector is without connector shroud. It is not possible to use a PC/104plus board with connector shroud at top at 3007632 and 3007632. This is only a mechanical limitation and does not reduce the functionality of 3007632 and 3007632. Please order a module without connector shroud or place 3007632/ 3007632 at top at the stack.

Module-dimensions: length * width 95 mm * 90 mm (3,7" * 3,5")

12.2 Electrical Specifications

Supply voltage: 5V DC +/- 5%

Supply voltage ripple: 100 mV peak to peak 0 - 20 MHz

Supply current (maximal): 1,8 A + current DRAM + current Prozessor
 (Σ max. current all Parts)

Supply current (typical, DOS-Prompt):
 with 166 MHz CPU and 64 MB SDRAM 1,55 A
 with 266 MHz CPU, Fan and 64 MB SDRAM 1,80 A
 external RTC battery voltage 2,4 – 4,0 V
 external RTC battery quiescent current max. 2 uA

The 3007632 is not a replacement for a backplane! It is strictly recommended to use all Power Pins on the PC/104 connector for power supply of the 3007632 and additional I/O cards.

The 3007632 is not a replacement for a backplane! It is not acceptable to use only the power pins of the PC/104plus PCI connector for power supply of the full PC/104 stack. The 3007632 is not a replacement for a backplane! Please refer the PC/104plus specification for the power supply of the 3007632 and all additional PC/104 I/O-cards.

12.3 Environmental Specifications

Temperature: operating 0 to +60 °C ((*with appropriate airflow)) except CPU and chipset (see below)
 non operating: -10 to +85 °C

The Intel Pentium® Processor with MMX™ Technology on 0.25 Micron is specified for proper operation when case temperature is within the specified range of 0°C to 95°C.
 The chipset M1531 and M1543C on the back side are specified for extended temperature range of 0°C to 85°C.

Humidity: operating: 10% to 90% (non-condensing)
 non operating: 5% to 95% (non-condensing)

(*) The maximum operating temperature is the maximum measurable temperature on any spot on the modules' surface. It is the user's responsibility to maintain this temperature within the specification, which is set by the IC manufacturer.

13. PERIPHERAL INTERFACE

13.1 Keyboard, Reset, Battery, Speaker

Signal name	Function	5-pin diode keyboard adapter	6-pin minidin keyboard adapter (PS2)
SPKR	speaker output		
GND	ground		
POWERGOOD	reset input		
/KLOCK	keyboard lock		
KDATA	keyboard data	2	1
KCLK	keyboard clock	1	5
GND	Ground	4	3
VCC	+5V	5	4
VBAT	VBAT input (3,6V)		
POWERGOOD	reset input		

/KLOCK (keyboard lock)

input on CPU modules
output on any other module
input to the keyboard controller input port 1 bit 7 .

POWERGOOD (reset input)

input on CPU modules
open collector output on all other module
When power good goes high, it starts the reset generator on the CPU module to pull the onboard reset line high after a valid reset period. This pin can also be used as a low active hardware reset for modules.

SPKR (speaker output)

open collector output on modules which can drive a loudspeaker.
input on modules which connect a 8 Ohm loudspeaker to this pin
An 8 Ohm loudspeaker is connected between SPEAKER and GND. Only one loudspeaker should be connected to this pin. Usually only the CPU drives this pin, however other modules can also use this signal to drive the system loudspeaker.

KDATA (keyboard data)

bi-directional I/O pin on CPU modules
Keyboard data signal.

KCLK (keyboard clock)

bi-directional I/O pin on CPU modules
Keyboard clock signal.

VBAT (system battery connection)

This pin connects a system battery to all modules.
The battery voltage has to be higher than 3.0V and lower than 4.0V. Either a 3V or 3.6V battery is recommended.
Note, that there is no battery needed to hold the CMOS-setup data. Your configuration concerning hard disks, floppy drives etc. is automatically saved in an onboard FRAM. Nevertheless the battery is necessary to serve the CMOS date and time while power consumption is turned off.

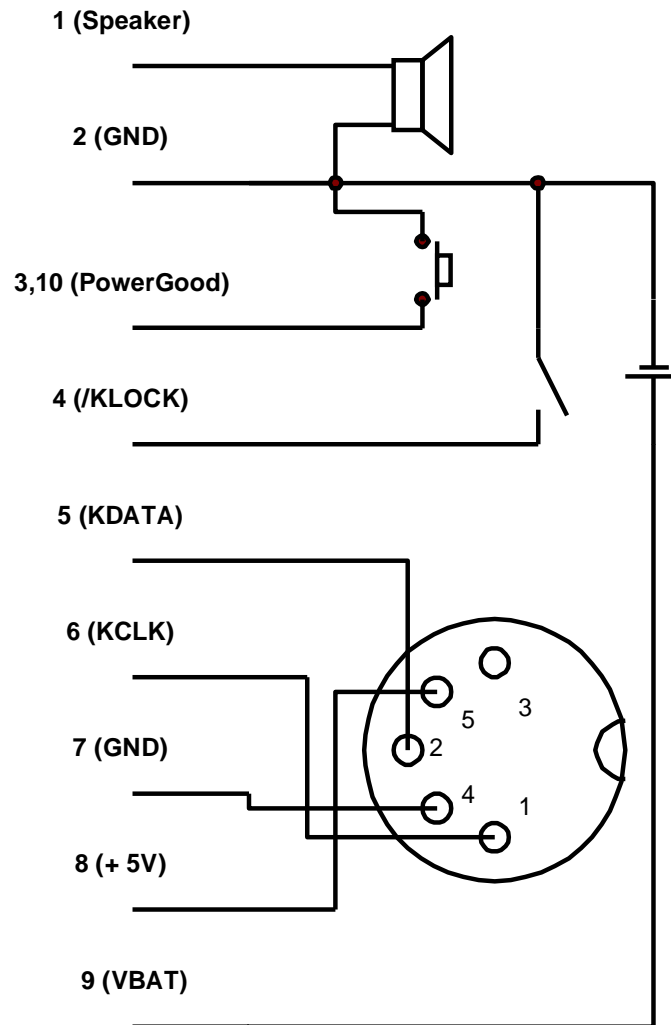

13.2 Serial Port COM A, B RS232C

Pin	Signalname	In / Out	DSUB-25 (need Adapter)	DSUB-9 (need Adapter)
1	DCD	In	8	1
2	DSR	In	6	6
3	RxD	In	3	2
4	RTS	Out	4	7
5	TxD	Out	2	3
6	CTS	In	5	8
7	DTR	Out	20	4
8	RI	In	22	9
9	GND	--	7	5
10	+5V	--	--	--

For signal description please refer to additional literature.

The four serial input/output interfaces can be set to any I/O-address on the peripheral setup. The serial ports are completely compatible with the serial port implementation used on the IBM Serial Adapter. Their default interrupts are mapped to IRQ4 and IRQ3.

13.3 Parallel Port LPT 1

Pin	Signalname	Function	In / Out	DSUB-25 (need Adapter)
1	/Strobe		Out	1
3	Data 0		I/O	2
5	Data 1		I/O	3
7	Data 2		I/O	4
9	Data 3		I/O	5
11	Data 4		I/O	6
13	Data 5		I/O	7
15	Data 6		I/O	8
17	Data 7		I/O	9
19	/ACK		in	10
21	BUSY		in	11
23	PAPER out		in	12
25	SEL out		in	13
2	/AUTOFD		out	14
4	/ERROR		in	15
6	/INIT		out	16
8	SEL in		out	17
26	Vcc	+ 5 V	--	NC
10,12	GND	Signal Ground	--	18 - 25
14,16	GND	Signal Ground	--	18 - 25
18,20	GND	Signal Ground	--	18 - 25
22,24	GND	Signal Ground	--	18 - 25

For signal description please refer to additional literature.

The Centronics printer interface can be programmed via the system setup menu. Refer to the peripheral setup for more information. The parallel port is completely compatible with the parallel port implementation used in the IBM PS-II-Parallel Adapter.

13.4 Floppy Connector

	Signal	Function	Pin	Signal	Function
1	VCC	+ 5V	2	IDX	index
3	VCC	+ 5V	4	DS0	drive select 0
5	VCC	+ 5V	6	/DCHNG	disk change
7	NC	-	8	NC	-
9	NC	-	10	Mo0	motor on
11	NC	-	12	DIR	direction select
13	NC	-	14	STEP	step
15	GND	ground	16	WD	write data
17	GND	ground	18	WG	write gate
19	GND	ground	20	TR00	track 00
21	GND	ground	22	WP	write protect
23	GND	ground	24	RD	read data
25	GND	ground	26	SIDE	side one select

For signal description please refer to additional literature.

13.5 IDE Connector for 2.5" Hard Disk

Pin	Signal	Pin	Signal
1	/RESET	2	GND
3	D7	4	D8
5	D6	6	D9
7	D5	8	D10
9	D4	10	D11
11	D3	12	D12
13	D2	14	D13
15	D1	16	D14
17	D0	18	D15
19	GND	20	NC
21	NC	22	GND
23	/IOW	24	GND
25	/IOR	26	GND
27	NC	28	BALE
29	NC	30	GND
31	IRQ14	32	/IOCS16
33	SA1	34	NC
35	SA 0	36	SA2
37	/CS0	38	/CS1
39	/HDLED	40	GND
41	VCC	42	VCC
43	GND	44	NC

For signal description please refer additional literatur.

13.6 Ethernet Connector

Pin	Signalname	Function	In/Out
1	TXD+	100/10BASE-T Transmit	differential Output
2	TXD-	100/10BASE-T Transmit	differential Output
3	RXD+	100/10BASE-T Receive	differential Input
4	NC	Unused Pin	
5	NC	Unused Pin	
6	RXD-	100/10BASE-T Receive	differential Input
7	NC	Unused Pin	Output
8	NC	Unused Pin	Output

TXD+, TXD-

Differential output pair drives 10 and 100Mb/s Manchester encoded data to the 100/10BASE-T transmit lines.

RXD+, RXD-

Differential input pair receives 10 and 100Mb/s Manchester encoded data from the 100/10BASE-T receive lines.

13.7 USB Connector

Pin	Pin function
1	+5V
2	USB-
3	USB+
4	GND

The power contacts on PIN 1 and 4 are only usable for internal USB devices. It's strictly recommended to use a fuse for power on external USB connectors.

13.8 Power Connector

Pin	Pin function
1	GND
2	+5V
3	VBAT
4	+12V
5	-5V
6	-12V
7	GND
8	+5V

Power Pins

The **3007632** is a +5 V only module. Nevertheless the power connector offers the possibility to supply with the additional voltages +12V, -12V and -5V which may be needed by other boards in the PC/104 system. The power consumption of all available power pins on the **3007632** is limited to 5A in total (1A per pin, with 2 pins on the power connector, 2 pins on the XT-bus and 1 pin on the AT-bus) and at GND up to 8A. Systems consuming more than 2A shouldn't be served over the power connector only. Systems consuming more than 5A must provide power supply through an additional connector on another board.

The 3007632 is not a replacement for a backplane! It's strictly recommended to use all Power Pins on the PC/104 connector for power supply of the 3007632 and additional I/O cards.

The 3007632 is not a replacement for a backplane! It's not acceptable to use only the power pins of the PC/104plus PCI connector for power supply of the full PC/104 stack.

VBAT (system battery connection)

This pin connects a system battery to all modules.

The battery voltage has to be higher than 3.0V and lower than 4.0V. Either a 3V or 3.6V battery is recommended.

Note, that there is no battery needed to hold the CMOS-setup data. Your configuration concerning hard disks, floppy drives etc. is automatically saved in an onboard FRAM. Nevertheless the battery is necessary to serve the CMOS date and time while power consumption is turned off.

13.9 PC/104-Connector

Specification XT Bus

Pin	Signal Name	Pin	Signal Name
A1	/IOCHCK	B1	GND
A2	SD7	B2	RESETDRV
A3	SD6	B3	+5V
A4	SD5	B4	IRQ9
A5	SD4	B5	-5V
A6	SD3	B6	DRQ2
A7	SD2	B7	-12V
A8	SD1	B8	/OWS
A9	SD0	B9	+12V
A10	IOCHRDY	B10	GND (*)
A11	AEN	B11	/SMEMW
A12	SA19	B12	/SMEMR
A13	SA18	B13	/IOW
A14	SA17	B14	/IOR
A15	SA16	B15	/DACK3
A16	SA15	B16	DRQ3
A17	SA14	B17	/DACK1
A18	SA13	B18	DRQ1
A19	SA12	B19	/REFRESH
A20	SA11	B20	SYSCLK
A21	SA10	B21	IRQ7
A22	SA9	B22	IRQ6
A23	SA8	B23	IRQ5
A24	SA7	B24	IRQ4
A25	SA6	B25	IRQ3
A26	SA5	B26	/DACK2
A27	SA4	B27	TC
A28	SA3	B28	BALE
A29	SA2	B29	+5V
A30	SA1	B30	OSC
A31	SA0	B31	GND
A32	GND	B32	GND

Specification AT Bus

Pin	Signal Name	Pin	Signal Name
C0	GND	D0	GND
C1	/SBHE	D1	/MEMCS16
C2	LA23	D2	/IOCS16
C3	LA22	D3	IRQ10
C4	LA21	D4	IRQ11
C5	LA20	D5	IRQ12
C6	LA19	D6	IRQ15
C7	LA18	D7	IRQ14
C8	LA17	D8	/DACK0
C9	/MEMR	D9	DRQ0
C10	/MEMW	D10	/DACK5
C11	SD8	D11	DRQ5
C12	SD9	D12	/DACK6
C13	SD10	D13	DRQ6
C14	SD11	D14	/DACK7
C15	SD12	D15	DRQ7
C16	SD13	D16	+5V
C17	SD14	D17	/MASTER
C18	SD15	D18	GND
C19	GND (*)	D19	GND

(*) Key pin for PC/104; GND for PC/104+ - specification

For signal description and peripheral driver current refer the PC/104 Specification. Any signals are open collector for multiple sources and can not drive by TTL.

14. LITERATURE, STANDARDS, LINKS

It is not in the responsibility of **GAI** to supply you with informations about standard PC technology. Please find below a selection of different information sources for your convenience.

14.1 PC/104-Bus

- **PC/104 Specification Version 2.3** June 1996
- **PC/104-Plus Specification Version 1.1** June 1997
- **PC/104 Consortium**; www.pc104.org
- **Embedded PCs**, Markt&Technik GmbH, ISBN 3-8272-5314-4 (german)

14.2 ISA-Bus, Standard PS/2 - Connectors

- **ISA System Architecture**, Addison-Wesley Publishing Company, ISBN 0-201-40996-8
- **AT BUS Design IEEE P996 Compatible**, Edward Solari, Annabooks San Diego CA. ISBN 0-929392-08-6 www.annabooks.com
- **PC Handbook, Sixth Edition**, John P. Choisser and John O. Foster, Annabooks San Diego CA. ISBN 0-929392-36-1, www.annabooks.com
- **AT IBM Technical Reference Vol 1&2**, 1985
- **ISA Bus Specifications and Application Notes**, January 30, 1990, Intel
- **Technical Reference Guide, Extended Industry Standard Architecture Expansion Bus**, Compaq 1989
- **Personal Computer Bus Standard P996**, Draft D2.00, January 18, 1990, IEEE Inc
- **Embedded PCs**, Markt&Technik GmbH, ISBN 3-8272-5314-4 (german)
- ePanorama PC Hardware Linkpage <http://www.us-epanorama.net/pc/>

14.3 RS232C

- EIA•232•E Interface between data terminal equipment and data circuit•terminating equipment employing serial binary data interchange (ANSI/IEA•232•D)

National Semiconductor's Interface Data Book includes any applications notes. These notes are also available online at <http://www.national.com/>. A search engine is provided to search the text of the available application notes. Entering „232“ as search criteria to get a current list of related application notes.

14.4 ATA

The ATA specification of X3T10 is available from several ftp servers. Please search for „ata3-r6“ on ftp search engines.

It is highly recommended to have a view on „4.2 I/O cable“ in this specification by using Harddisks on DMA3 or PIO4-Mode.

14.5 USB

The USB specification maybe obtained from the USB Implementers Forum web site at www.usb.org

14.6 PCI

The PCI specification maybe obtained from the PCI Special Interest Group web site at <http://www.pcisig.com/>.

15. DOCUMENT REVISION HISTORY

Filename	Date	Edited by	Alteration to preceding revision
P588D210.DOC	06.09.99	BJ	Created preliminary
P588D211.DOC	25.11.99	KW	Correct VGA, add USB, ATA, temperature, preliminary
P588D212.DOC	07.12.99	KW	substantiate Temp Spec
P588D213.DOC	13.01.00	KW	Correct USB connector pg. 39; mechanical limitation of PC/104plus pg. 34
P588D214.DOC	22.05.00	KW	Add 266 MHz; change 82559 to 82559ER; Backplane warning; PCI-Spec 14.6;
	21.08.00	RC	BIOS description updated

Any advice or comments about our products and service, or anything we can help you with please don't hesitate to contact with us. We will do our best to support you for your products, projects and business

Global American Inc.

Address: 17 Hampshire Drive
Hudson, NH 03051

TEL: Toll Free (U.S. Only) 800-833-8999
(603)886-3900

FAX: (603)886-4545

Website: <http://www.globalamericaninc.com>

E-Mail: salesinfo@globalamericaninc.com

