



integration with integrity

2907740 User's Manual

17" Fanless Panel PC Heavy Duty Touch Screen

Version 1.0 August 2008

Copyrights

This document is copyrighted and all rights are reserved. It does not allow any non authorization in copied, photocopied, translated or reproduced to any electronic or machine readable form in whole or in part without prior written consent from the manufacturer.

In general, the manufacturer will not be liable for any direct, indirect, special, incidental or consequential damages arising from the use of inability to use the product or documentation, even if advised of the possibility of such damages. The manufacturer keeps the rights in the subject to change the contents of this document without prior notices in order to improve the function design, performance, quality and reliability. The author assumes no responsibility for any errors or omissions, which may appear in this document, nor does it make a commitment to update the information contained herein.

Trademarks

Intel is a registered trademark of Intel Corporation.

Award is a registered trademark of Award Software, Inc.

All other trademarks, products and or product's name mentioned herein are mentioned for identification purposes only, and may be trademarks and/or registered trademarks of their respective companies or owners.

Table of Contents

Chapter 1	General Description	1
1.1	Major Features	2
1.2	Specifications	2
1.3	Panel Specifications	3
1.4	Dimensions	4
Chapter 2	Unpcking	5
2.1	Opening the Delivery Package	5
2.2	Inspection.....	5
Chapter 3	Hardware Installation	7
3.1	Open the Cover.....	7
3.2	HDD/CD-ROM Installation.....	8
3.3	SBC Installation.....	9
3.4	USB Device Installation	10
3.5	Wallmount Installation	10
Chapter 4	Touch Screen Driver Installation	11
4.1	Resistive Type Touch Screen Driver Installation	11
4.1.1	Installing Touch Screen Driver in WIN95/98	11
4.1.2	Installing Touch Screen Driver in WIN2000	13
4.1.3	PenMount Control Panel.....	15
4.1.4	PenMount Monitor	17
4.2	SAW Type Touch Screen Driver Installation	18

Safety Instructions

The safety recommendations outlined in this section are to be read, understood and followed before operating the product. Keep this information in a safe place for future reference. Failure to comply with any of the following safety procedures could result in serious hazard.

- Do not operate product for any purposes other than its intended use
- This product is intended for indoor use only
- Do not operate product if power cord is damaged in anyway
- Do not insert objects into openings
- Do not immerse product in water or permit liquids to spill inside
- Turn off power when unattended or not in use. Unplug product before moving it or when it is not in use for an extended period of time. The socket-outlet shall be installed near the equipment and shall be easily accessible
- Do not alter or extend electric plug. Plug is configured for appropriate electrical supply
- Do not overload electrical outlets beyond their capacity as this can result in a fire

NOTE: *DO NOT TOUCH THE PRODUCT OR ANY OTHER SENSITIVE COMPONENTS WITHOUT ALL NECESSARY ANTI-STATIC PROTECTIONS.*

Life Expectancy of Constituent Parts

This section describes the life expectancy of constituent parts (backlight, power supply, internal cooling fan and touch screen) which make up to 2907740.

- **TFT Display Backlight**
Display brightness decreases over time with use. The expected operating lifetime of the backlight time to reach 50% initial brightness) is 30,000 hours (assuming continuous lit state at 25 degrees C). Actual lifetime before replacement is about 30,000 hours, although this depends on operating conditions.
 - **Touch Screen**
The operating lifetime of the touch screen is approximately 1 million operations (as tested by mechanical manipulation under 100g of force at a rate of two presses per second)
-

This page intentionally left blank.

Chapter 1

General Description

2907740
Ultra Slim, 17" Fanless Panel PC, CPU Speed up to 1.8GHz,
Heavy Duty Touch Screen



The 2907740 is a newest Industrial Panel PC, Panel PC features anti-vibration design and is a best cost-effective alternative for users. This precise streamline platform can be applied to Kiosk, DSA, transaction terminal, POS, home security system, ATM system and voting machine parking field and more.

it has a built-in ultra low power consumption Intel® mobile processor is response to demands of cost-effective panel system. 2907740 series Panel PC Support resistive/SAW touch screens, highly expandable, it is an ideal for space-limited environments, and furthermore it supports an optional rotational WLAN antenna for wireless network connection.

Anti-vibration

With an unique anti-vibration design, 2907740 series Panel PC has been approved for vibration tests at Intel® Pentium® M 1.8GHz in operation mode with Hard Disk

Ultra slim design: 55~61 mm thickness

With streamlined mechanical layout, 2907740 series panel PC has an ultra slim thickness for space-limited environment. It not only decreases maintenance time but also saves the space considerably.

Cost-effective Fanless Embedded System

2907740 series Panel PC, the most slim, compact size, fanless embedded computer, is powered by an ultra low power processor, VIA Eden 1GHz CPU onboard, The total power consumption of the system is under 27W merely. Both power and cost saving, it generates less volume as well. Without hard disk space and extra add-on cards, All of the series panel PC presents a super slim design and provides a cost-effective alternative for users. I/O feature contains VGA, COM, dual LAN, USB 2.0, and PS/2 connectors. Moreover, it reserved a CompactFlash socket for storage device.

1.1 Major Features

The 2907740 series comes with the following features:

- Ultra slim, fanless, aluminum front panel design
- 17" TFT color panel display
- Built-in mainboard, VIA Eden 1GHz CPU, 60W power adapter
- Provides Heavy Duty touch screen, dimmer controller, wireless LAN module (optional)
- Onboard graphics, dual ethernet, audio controller
- CF, 4 COM, 1 USB2.0
- 2.5" HDD space x 1, slim CD-ROM space x 1

1.2 Specifications

- **CPU:** VIA Eden 1GHz CPU
- **Memory:** One SO-DDRII socket support up to 1GB
- **Chipset:** VIA CX700(M)
- **Touch Screen:** 17" resistive (3.1mm) or SAW (6mm) touch screen (optional)
- **Dimmer Controller:** Dimmer controller on front panel (optional)
- **Display:** Onboard graphics controller
- **Ethernet:** Onboard dual 10/100 Based controller
- **Wireless LAN:** Provides Wireless LAN module (optional)

-
- **Audio:** Onboard HDAC codec
 - **Storage:**
 - Type I/II CF adapter x 1
 - 3.5" HDD/FDD space x 1
 - Slim CD-ROM space x 1
 - **Serial Port:** 4 ports
 - **USB:** USB2.0 port x 1
 - **Keyboard/ Mouse:** PS/2 6-pin Mini DIN
 - **BIOS:** AMI PnP Flash BIOS
 - **Watchdog Timer:** Software programmable time-out intervals from 1~255 sec.
 - **Power In:** 60W power adapter
 - **Temperature:** 0~+45 °C (operating); -20~+70 °C (storage)
 - **Dimensions:** 45.0(L) x 6.1(H) x 37.0 (W) cm

1.3 Panel Specifications

- **Screen Size:** 17 inches
- **Display Format:** 1280 x 1024 pixels
- **Pixel Pitch:** 0.26(H) x 0.26(V) m/m
- **Color:** 16.7M colors
- **Brightness:** R.G.B. Vertical Stripe
- **Contrast Ratio:** 800:1
- **MTBF:** 300 cd/m² @ 7.5mA

1.4 Dimensions

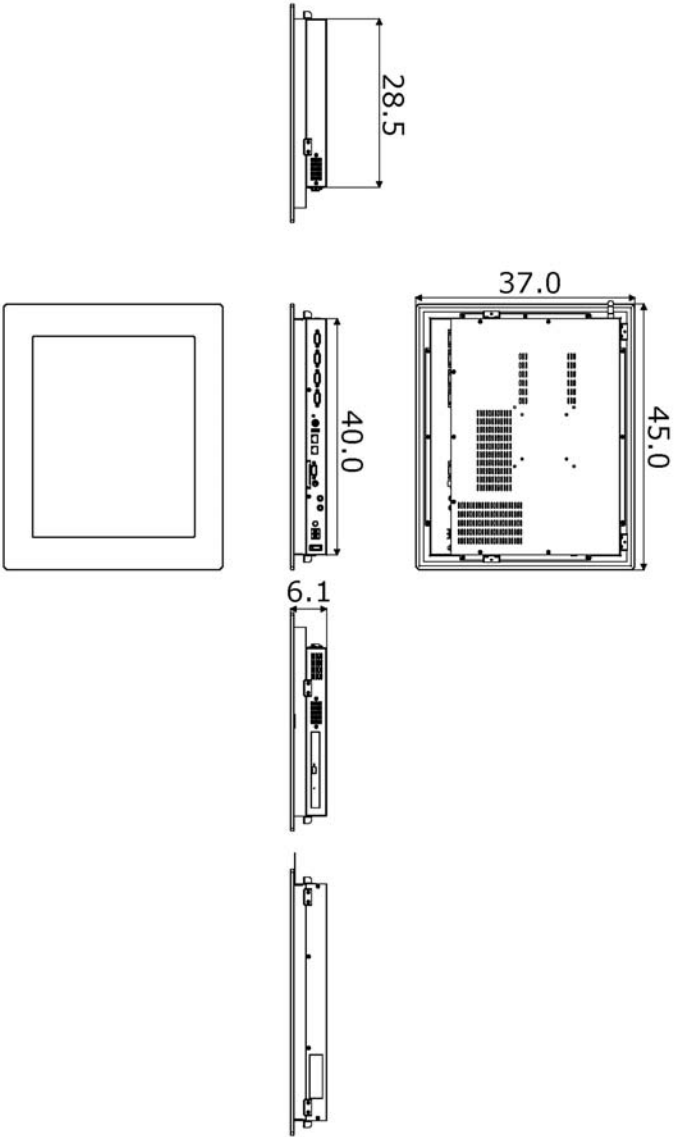

Chapter 2

Unpacking

2.1 Opening the Delivery Package

The 2907740 is packed in an anti-static bag. The board has components that are easily damaged by static electricity. Do not remove the anti-static wrapping until proper precautions have been taken. Safety instructions in front of this manual describe anti-static precautions and procedures.

2.2 Inspection

After unpacking the Panel PC, place it on a raised surface and carefully inspect the board for any damage that might have occurred during shipment. Ground the board and exercise extreme care to prevent damage to the board from static electricity.

Integrated circuits will sometimes come out of their sockets during shipment. Examine all integrated circuits, particularly the BIOS, processor, memory modules, ROM-Disk, and keyboard controller chip to ensure that they are firmly seated. The 2907740 delivery package contains the following items:

It is recommended that you keep all the parts of the delivery package intact and store them in a safe/dry place for any unforeseen event requiring the return shipment of the product. In case you discover any missing and/or damaged items from the list of items, please contact your dealer immediately.

This page intentionally left blank.

Chapter 3

Hardware Installation

This chapter tells how to install components into the Panel PC system. External interface please refers to system board's manual.

3.1 Open the Cover

1. Remove screws from the back cover accordingly.

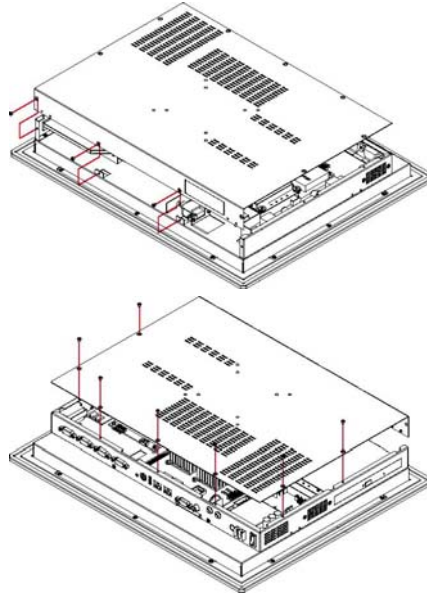

3.2 HDD/CD-ROM Installation

1. Remove the HDD drive bay holding bracket.

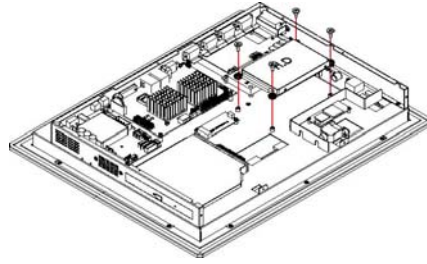

2. Install the holding bracket with HDD, then re-install HDD drive bay back to chassis.

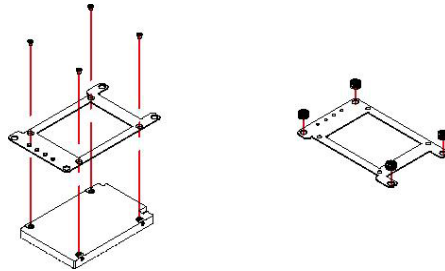

3. Remove the CD-ROM drive holding bracket.

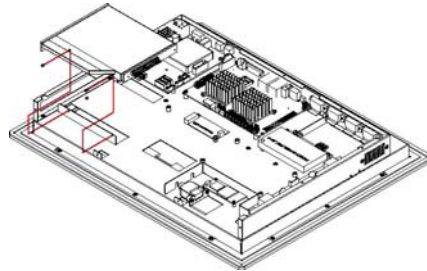

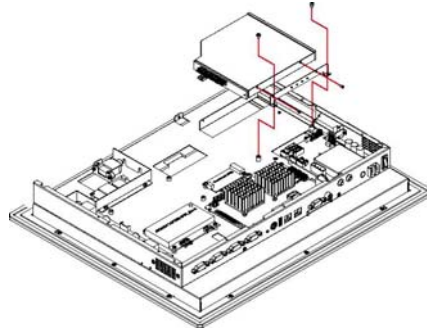

4. Install the holding bracket with CD-ROM, then re-install CD-ROM drive bay back to chassis.

3.3 SBC Installation

1. Install the SBC with chassis.

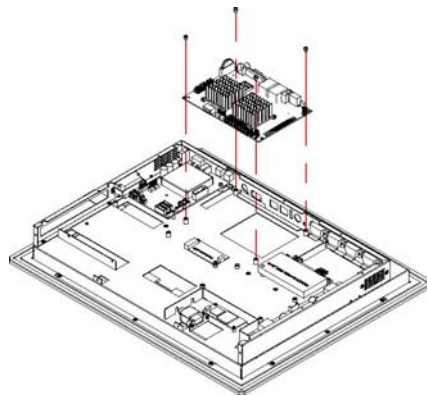

2. Use two screws install SBC with front panel.

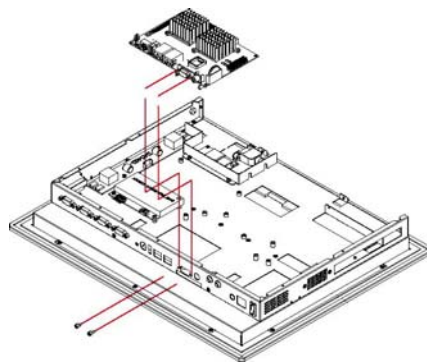

3.4 USB Device Installation

1. User can install USB type wireless LAN module as below.

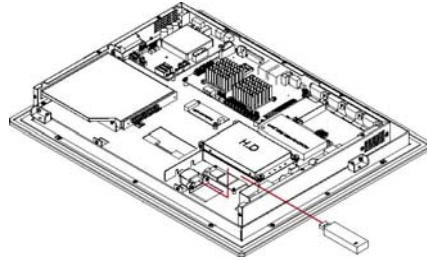

3.5 Wallmount Installation

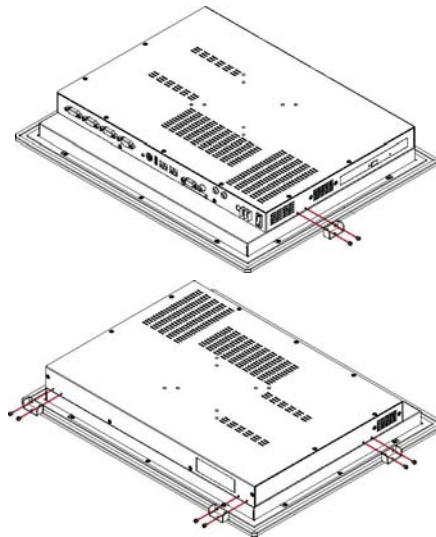

Chapter 4

Touch Screen Driver Installation

This chapter contains the detailed information of touch screen driver installation procedures. The utility disk that came with the delivery package contains an auto-run program that invokes the installation programs for the touch screen driver. The following sections describe the installation procedures of driver based on WIN2000 operating systems. It is recommended that you install the drivers matching the sections listed in this chapter.

4.1 Resistive Type Touch Screen Driver Installation

4.1.1 Installing Touch Screen Driver in WIN95/98

1. Insert Utility CD disk to your CD-ROM drive. The main menu will pop up as shown below.
2. The screen displays copying "Installation Wizard" and "PenMount Utilities Installation" screen plus "welcome" message appear, click on **Next>**.

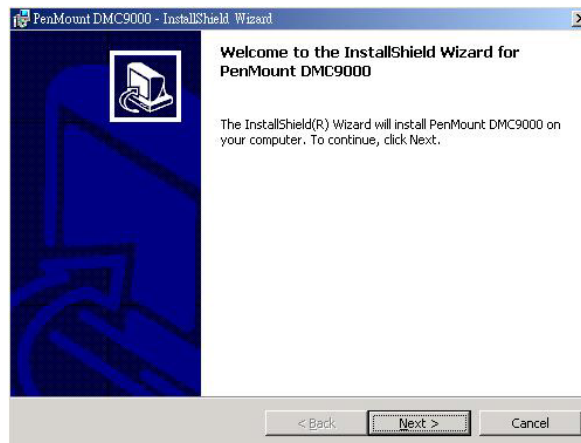

3. The next screen is "Software License Agreement", select "I accept" and click on **Next>**.

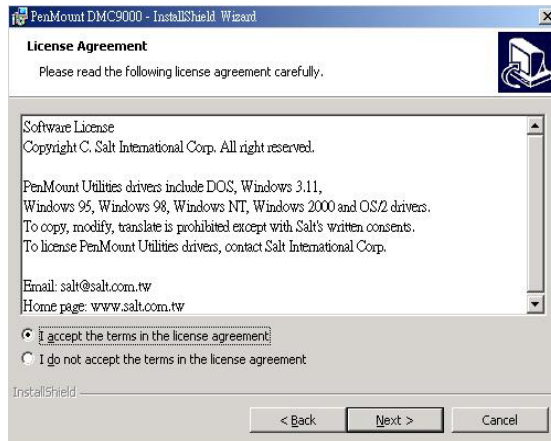

4. The next screen is Ready to Install the Program, click on **Install**.

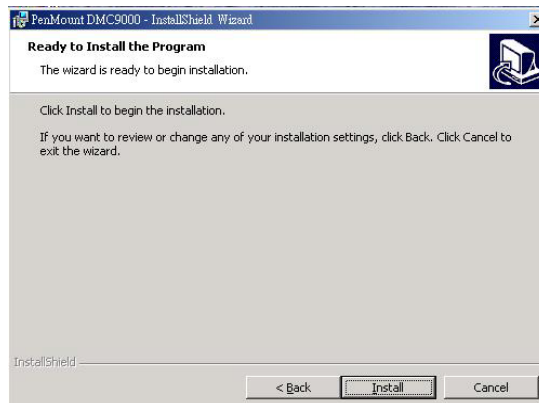

5. Once the Install Shield Wizard finishes updating your system, it will prompt you to restart the computer. Click on **Finish** to exit the wizard.

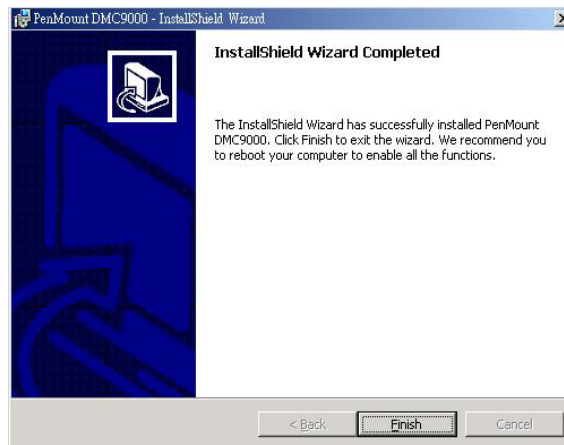

4.1.2 Installing Touch Screen Driver in WIN2000

1. Insert Utility CD Disk to your CD-ROM drive. The main menu will pop up as shown below.
2. The screen displays copying Installation Wizard and PenMount Utilities Installation screen plus welcome message appear, click on **Next>**.



3. The next screen is Software License Agreement, select I accept and click on **Next>**.

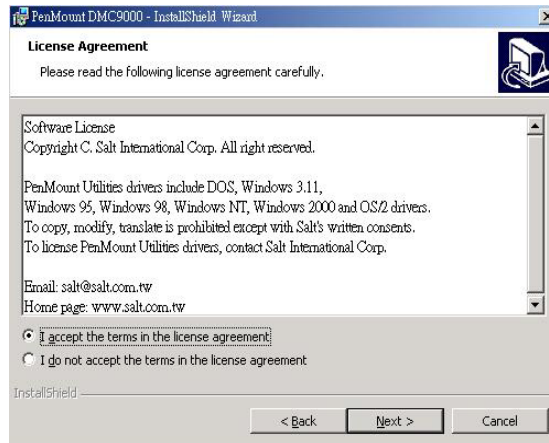

4. The next screen is Ready to Install the Program, click on **Install**.

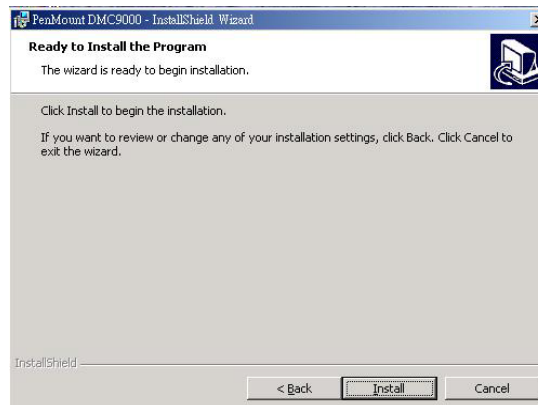

5. Once the Install Shield Wizard finishes updating your system, it will prompt you to restart the computer. Click on **Finish** to exit the wizard.

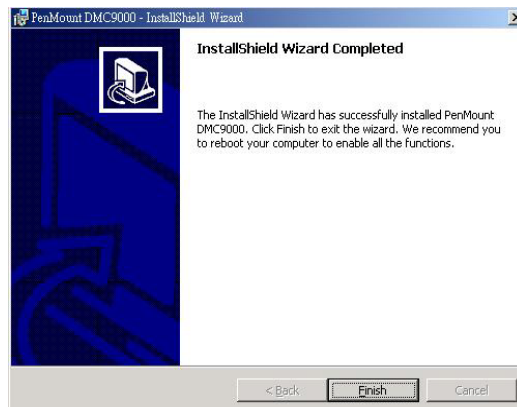

4.1.3 PenMount Control Panel

- **Calibrate**

To adjust the display with touch screen, click on Calibration and follow the calibrate point to do calibration, there are five points on screen for calibration.



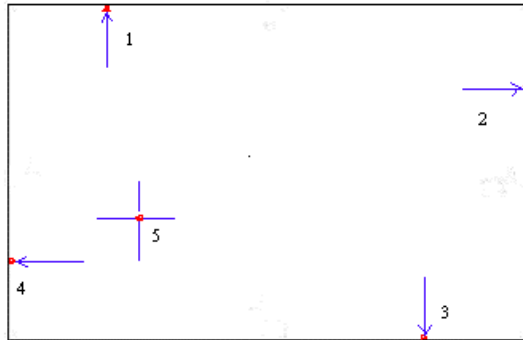

- **Draw**

Test or demonstrate PenMount touch screen operation, also the touch location is shown on the display, touch DRAW to start.

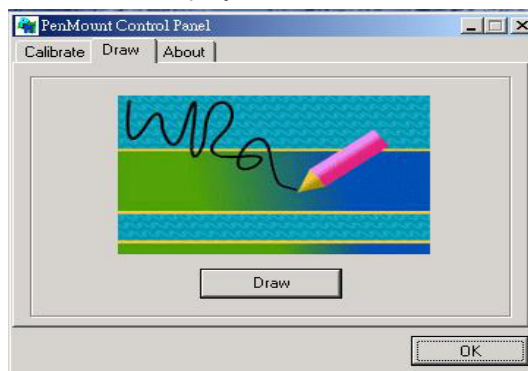

- **About**

It shows information about PenMount controller and this driver.

4.1.4 PenMount Monitor

The PenMount monitor icon is shown in the menu bar of WIN2000 system when turn on PenMount monitor from PenMount Utilities.



There are several functions on PenMount monitor:

- **Right Click Button**

When select this function, there is a mouse icon shown in the right-button place of screen. It shows Left Button being as default for normal use, touch this mouse icon to change the next touch to be Right Button function. After one touch, the mouse icon will change to Left Button automatically. If user needs to use right button again, user has to touch the mouse icon again for changing the button function.

- **Beep**

Turn on or off beep sound.

- **Exit**

Close the PenMount Monitor function.

4.2 SAW Type Touch Screen Driver Installation

1. Insert Utility CD disk to your CD-ROM drive. The main menu will pop up as shown below.

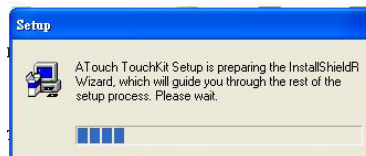

2. The screen displays copying "Setup" and "TouchKit Setup" screen message appear, click on **Next>**.

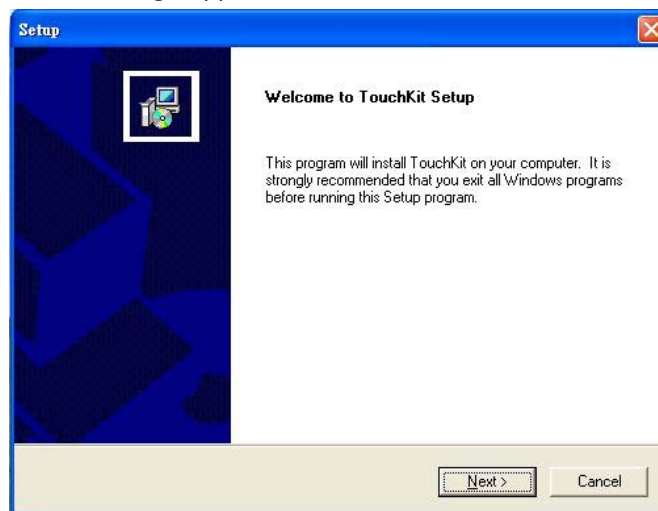

3. The next screen is as below, and click on **Next>**.

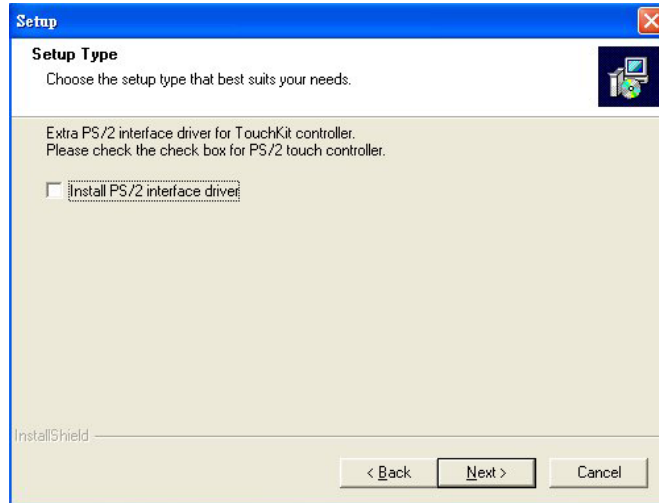

4. The next screen is chooses the setup type that "Do 4 point calibration", select "None" and click on **Next>**.

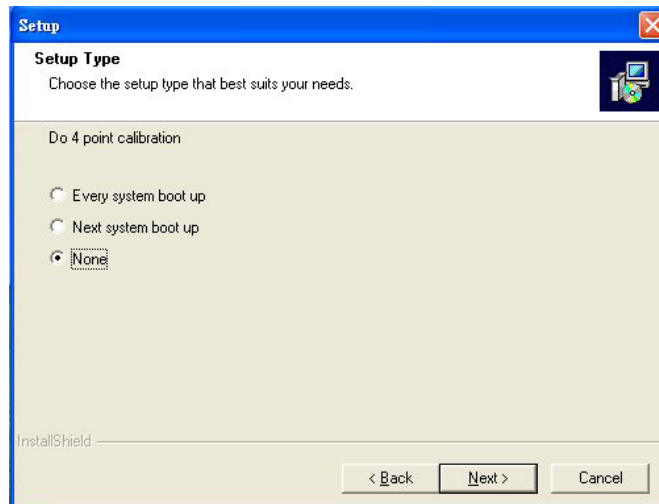

5. Choose the drivers install location, and click on **Next>**.

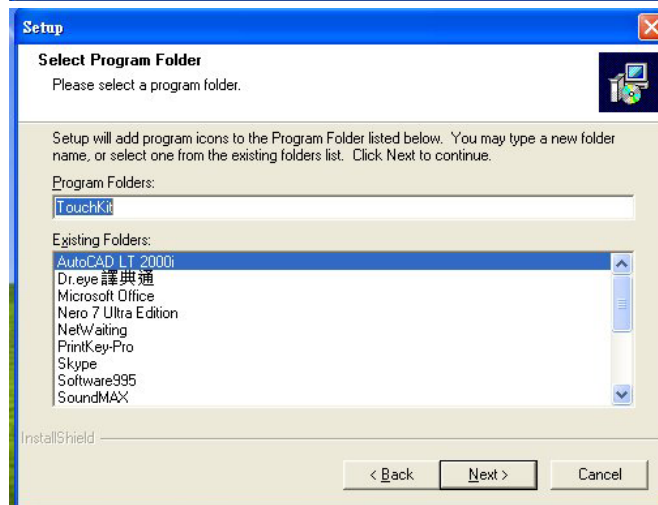
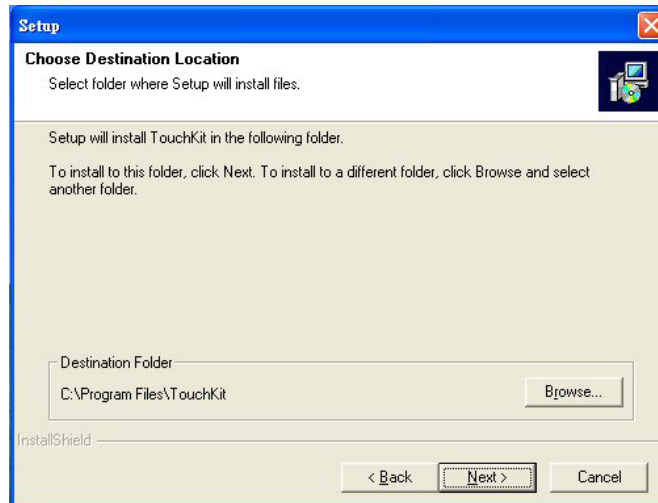

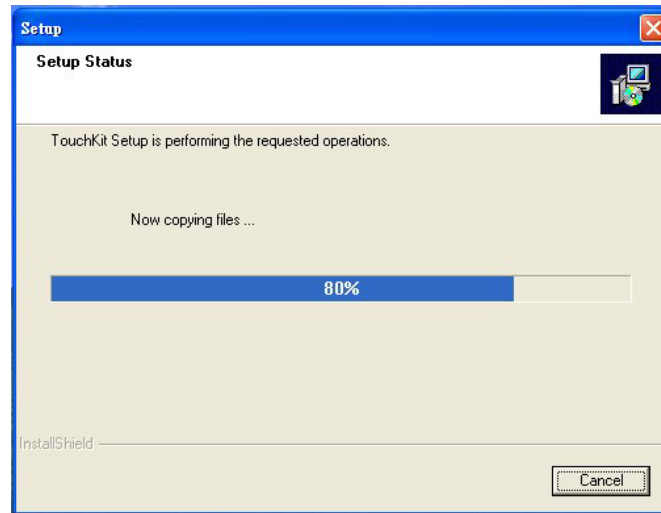

6. When the TouchKit setup finish, you will see an icon names "TouchKit" in your desktop.



Any advice or comments about our products and service, or anything we can help you with please don't hesitate to contact with us. We will do our best to support your products, projects and business.



Address: Global American, Inc.
17 Hampshire Drive
Hudson, NH 03051

Telephone: Toll Free U.S. Only (800) 833-8999
(603) 886-3900

FAX: (603) 886-4545

Website: <http://www.globalamericaninc.com>

Support: Technical Support at Global American
