



**User's Manual**

**2901300**

**Version 1.0**

**July 2006**

### Copyrights

This manual is copyrighted and all rights are reserved. It does not allow any non authorization in copied, photocopied, translated or reproduced to any electronic or machine readable form in whole or in part without prior written consent from the manufacturer.

In general, the manufacturer will not be liable for any direct, indirect, special, incidental or consequential damages arising from the use of inability to use the product or documentation, even if advised of the possibility of such damages. The manufacturer keeps the rights in the subject to change the contents of this manual without prior notices in order to improve the function design, performance, quality and reliability. The author assumes no responsibility for any errors or omissions, which may appear in this manual, nor does it make a commitment to update the information contained herein.

### Trademarks

Intel is a registered trademark of Intel Corporation.

Award is a registered trademark of Award Software, Inc.

All other trademarks, products and or product's name mentioned herein are mentioned for identification purposes only, and may be trademarks and/or registered trademarks of their respective companies or owners.

## 2901300 Flat Panel PC

### PACKING LIST

Before installing the LCD workstation, please make sure that the following items have been shipped:

<i>f</i>	1 x Carton
<i>f</i>	1 x Power cable
<i>f</i>	1 x IDE cable
<i>f</i>	1 x CPU cooler
<i>f</i>	1 x Driver CD
<i>f</i>	1 x Supplementary screw set

If any of these items are missing or damaged, contact the distributor or sales representative immediately.

### PRECAUTIONS

#### SAFETY PRECAUTIONS

1. Prior to installing, moving, and modifying the workstation, make sure that the unit's power is turned off and the power cord is disconnected.
2. Do not apply voltage levels that exceed the specified voltage range. Doing so may cause fire or an electrical shock.
3. Electric shock can occur if the panel is opened. Do not drop or insert any objects into the ventilation openings of the workstation.
4. Only qualified engineers from certified system integrators or VARs are allowed to make necessary functional modifications to the workstation, e.g., adding a touch screen. Global American, Inc. (GAI) offers the customization service on a pre-order basis.
5. If considerable amount of dust, water, or fluids entered the workstation, turn off the power supply immediately, unplug the power cord, and contact the vendor.
6. Explosions may occur with installations in environments where flammable gases are present.
7. Fault-tolerant and failsafe designs should be implemented with the use of the series models on transportation vehicles, ships, safety/security devices, or medical devices not related to life-support functionalities. Users/integrators should take the responsibility for implementations with adequate levels of reliability and safety.

8. Preventive designs should be implemented so as to avoid the communications faults between the workstation and the PC/workstation/terminals that controls it.

**HANDLING PRECAUTIONS**

1. Do not drop the workstation against a hard surface. Doing so may damage the display.
2. Do not strike or exert excessive force onto the touch panel.
3. Touching the touch panel using a sharp object may damage the LCD panel.
4. Avoid environments exposed to direct sunlight, dust, or chemical vapors.
5. The workstation is actively cooled. In no circumstances should the workstation operate with the openings obstructed by foreign objects. However, the ambient temperature of the installation site should be observed and controlled to avoid overheating the workstation.
6. Condensation might form inside the workstation chassis if exposed to sudden changes in temperature.
7. Carefully route the power cord so that people cannot step on it. Do not place anything over the power cord.
8. If the equipment should be left unused for an extended period of time, disconnect it from the power source to avoid damage by transient over-voltage.
9. If any of the following situations arises, get the equipment checked by service personnel:
  - The power cord or plug is damaged.
  - Liquid has penetrated into the equipment.
  - The equipment has been exposed to moisture.
  - The equipment does not work properly, or the user cannot get it to work according to the user manual.
  - The equipment has been dropped and damaged.
  - The equipment shows obvious signs of breakage.



**WARNING!**

Any changes or modifications made to the equipment that are not expressly approved by the relevant standards could void the authority to operate the equipment.

---

**ADDITIONAL INFORMATION**

**MAINTENANCE AND CLEANING**

Note the following precautions before beginning to clean the LCD workstation.

When cleaning any single part or component of the computer, please read and understand the details below fully.

- f* Except for the properly installed front LCD panel, never spray or squirt liquids directly onto any computer component. To clean the device, please rub it with a piece of dry and soft cloth or a slightly moistened cloth with the exterior casing.
- f* The interior of the LCD workstation does not require cleaning. Keep fluids away from the LCD workstation and the interior of it.
- f* Be cautious of the tiny removable components when using a vacuum cleaner to absorb the dirt on the floor.
- f* Turn the system off before cleaning up the LCD workstation.
- f* Never drop any tiny objects through the openings of the LCD workstation or get circuit board damp or wet.
- f* Be cautious of all kinds of cleaning solvents or chemicals when using it for the sake of cleaning. Some individuals may be allergic to the ingredients.
- f* Avoid any food, drink or cigarette around the LCD workstation.

## CLEANING TOOLS

Although many companies have created products to help improve the process of cleaning the computer and peripherals, users can also use household items to clean their computers and peripherals. Below is a list of items to use while cleaning the computer or computer peripherals.

Please keep in mind that some components in the computer may only be cleaned using a product designed for cleaning that component, if this is the case it will be mentioned in the cleaning tips.

- f **Cloth** - A piece of cloth is the best tool to use when rubbing up a component. Although paper towels or tissues can be used on most hardware as well, it is recommended to rub it with a piece of cloth.
- f **Water or rubbing alcohol** – Moisten a piece of cloth a bit with some water or rubbing alcohol and rub it on the computer.
- f Unknown solvents may be harmful to the plastics parts.
- f **Vacuum cleaner** - Absorb the dust, dirt, hair, cigarette particles, and other particles out of a computer can be one of the best methods of cleaning a computer. Over time these items can restrict the airflow in a computer and cause circuitry to corrode.
- f **Cotton swabs** - Cotton swabs moistened with rubbing alcohol or water are excellent tools for wiping hard to reach areas in the keyboard, mouse, and other locations.
- f **Foam swabs** - Whenever possible it is better to use lint free swabs such as foam swabs.

## ESD PRECAUTIONS

Observe all conventional anti-ESD methods while handling the components contained within the LCD should the need arise for adding a functionality. The use of a grounded wrist strap and an anti-static work pad is recommended. Avoid dust and debris or other static-accumulating materials in the work area.

## MANUAL CONVENTIONS



### **WARNING!**

Warnings appear where overlooked details may cause damage to the equipment or result in personal injury. Warnings should be taken seriously. Warnings are easy to recognize. The word “warning” is written as “**WARNING**,” both capitalized and bold and is followed by text in italics. The italicized text is the warning message.



### **CAUTION!**

Cautionary messages should also be heeded to reduce the chance of losing data or damaging the system. Cautions are easy to recognize. The word “caution” is written as “**CAUTION**,” both capitalized and bold and is followed by text in italics. The italicized text is the cautionary message.



### **NOTE:**

These messages inform the reader of essential but non-critical information. These messages should be read carefully as any directions or instructions contained therein can avoid making mistakes. Notes are easy to recognize. The word “note” is written as “**NOTE**,” both capitalized and bold and is followed by text in italics. The italicized text is the cautionary message.

## **Lists**

**Bulleted Lists:** Bulleted lists are statements of non-sequential facts that can be read in any order. Each statement is preceded by a round black dot “•” or bullets in other shapes.

**Numbered Lists:** Numbered lists describe sequential steps should be followed in order.

# Table of Contents

---

<b>1</b>	<b>INTRODUCTION.....</b>	<b>15</b>
1.1	2901300 FLAT PANEL PC OVERVIEW .....	16
1.1.1	<i>2901300 Model Variation.....</i>	16
1.1.2	<i>2901300 Flat Panel PC Applications.....</i>	16
1.1.3	<i>2901300 Flat Panel PC Features.....</i>	16
1.2	2901300 EXTERNAL OVERVIEW.....	17
1.2.1	<i>General Description.....</i>	17
1.2.2	<i>Front Panel .....</i>	17
1.2.3	<i>Rear Panel .....</i>	18
1.2.4	<i>Top Panel .....</i>	18
1.2.5	<i>2901300 Bottom Panel.....</i>	18
1.2.6	<i>Right Side Panel.....</i>	19
1.2.7	<i>Left Side Panel.....</i>	20
1.2.8	<i>Frame.....</i>	20
1.3	2901300 INTERNAL OVERVIEW .....	21
1.4	2901300 SPECIFICATIONS.....	21
1.4.1	<i>Preinstalled Hardware Components .....</i>	21
1.4.2	<i>System Specifications .....</i>	21
1.4.3	<i>2901300 Motherboard Specifications .....</i>	22
1.4.4	<i>Flat Panel Screen.....</i>	23
1.4.5	<i>Power Supply Unit (PSU).....</i>	24
1.5	OEM CUSTOMIZATIONS.....	25
1.6	DIMENSIONS .....	26
<b>2</b>	<b>2804150 MOTHERBOARD .....</b>	<b>27</b>
2.1	INTRODUCTION .....	28
2.2	CPU SUPPORT.....	28
2.3	ONBOARD CHIPSETS .....	28
2.3.1	<i>Northbridge and Southbridge Chipsets .....</i>	28
2.3.2	<i>855GME Northbridge Chipset.....</i>	28
2.3.3	<i>ICH4 Southbridge Chipset.....</i>	29
2.4	GRAPHICS SUPPORT .....	30

2.4.1	Display.....	30
2.4.2	Internal Graphics Features.....	30
2.4.3	Intel® Embedded Graphics Drivers.....	30
2.5	PERIPHERAL DEVICE INTERFACES, CONNECTORS, AND SLOTS.....	31
2.5.1	OEM Options.....	31
2.5.2	Internal Slots.....	31
2.5.3	Internal Peripheral Device Connectors.....	31
2.5.4	External Peripheral Device Connectors.....	32
2.6	PCI RISER CARD.....	32
<b>3</b>	<b>INSTALLATION AND CONFIGURATION .....</b>	<b>33</b>
3.1	INSTALLATION PRECAUTIONS.....	34
3.2	PREINSTALLED COMPONENTS .....	34
3.3	INSTALLATION AND CONFIGURATION STEPS.....	35
3.4	UNPACKING.....	35
3.5	JUMPER SETTINGS.....	35
3.5.1	Remove the Back Cover.....	36
3.5.2	JP2: Clear CMOS Setup.....	37
3.5.3	JP4: CF Card Setup.....	38
3.5.4	JP5: LCD Voltage Setup.....	38
3.5.5	CN13: COM Port Jumper Setting.....	39
3.6	MOUNTING THE SYSTEM.....	40
3.6.1	Wall Mounting.....	40
3.6.2	Panel Mounting.....	42
3.6.3	Arm Mounting.....	44
3.7	REAR PANEL CONNECTORS .....	46
3.7.1	LCD Panel Connection.....	46
3.7.2	Ethernet Connection.....	46
3.7.3	USB Connection.....	46
3.7.4	Keyboard and Mouse Connection.....	46
<b>4</b>	<b>SYSTEM MAINTENANCE .....</b>	<b>47</b>
4.1	SYSTEM MAINTENANCE INTRODUCTION.....	48
4.2	MOTHERBOARD REPLACEMENT.....	48
4.3	BACK COVER REMOVAL AND ELEVATED PLATFORM DETACHMENT .....	48
4.3.1	Back Cover Removal.....	48

4.3.2 *Detaching the Elevated Platform*..... 51

4.4 DIMM REPLACEMENT..... 52

4.5 PSU MODULE REPLACEMENT..... 53

**A INTERFACE CONNECTORS ..... 56**

**THIS PAGE IS INTENTIONALLY LEFT BLANK**

# List of Figures

---

Figure 1-1: 2901300 Front View.....	17
Figure 1-2: 2901300 Rear View.....	18
Figure 1-3: 2901300 Top View .....	18
Figure 1-4: Bottom View .....	19
Figure 1-5: Right View.....	19
Figure 1-6: Left View .....	20
Figure 1-7: Frame Rear View (12 panel mount retention screws).....	20
Figure 1-8: Dimensions (units in mm).....	26
Figure 3-1: Rear Cover Retention Screws (Real Panel).....	37
Figure 3-2: Rear Cover Retention Screws (Top Panel).....	37
Figure 3-3: Rear Cover Retention Screws (Bottom Panel).....	37
Figure 3-4: Wall-mounting Bracket.....	41
Figure 3-5: Chassis Support Screws.....	41
Figure 3-6: Mount the Chassis.....	42
Figure 3-7: Cut the Panel.....	43
Figure 3-8: Panel Mounting Clamp Positions.....	43
Figure 3-9: Tighten the Panel Mounting Clamp Screws.....	44
Figure 3-10: Arm Mount Retention Screw Holes.....	45
Figure 4-1: Rear Cover Retention Screws (Real Panel).....	50
Figure 3-2: Rear Cover Retention Screws (Top Panel).....	50
Figure 4-2: Rear Cover Retention Screws (Bottom Panel).....	50
Figure 4-3: Elevated Platform Retention Screws (Top Panel) .....	51
Figure 4-4: Elevated Platform Retention Screws (Right Panel).....	51
Figure 4-5: Elevated Platform Retention Screws (Bottom Panel) .....	52
Figure 4-6: PCI Riser Card Retention Screws .....	52
Figure 4-7: DIMM Socket Clip Locations.....	53
Figure 4-8: PSU Motherboard Connector .....	54
Figure 4-9: PSU Internal Retention Screws .....	54
Figure 4-10: PSU External Retention Screws .....	55

# List of Tables

---

Table 1-1: 2901300 Model Variation.....	16
Table 1-2: 2901300 Specifications .....	22
Table 1-3: Motherboard Specifications .....	23
Table 1-4: 15" TFT LCD Monitor Specifications.....	24
Table 1-5: Power Supply Specifications .....	25
Table 3-1: Clear CMOS Jumper Settings .....	38
Table 3-2: CF Card Setup Jumper Settings .....	38
Table 3-3: LCD Voltage Setup Jumper Settings.....	39
Table 3-4: COM Port Jumper Settings.....	39

**THIS PAGE IS INTENTIONALLY LEFT BLANK**

Chapter

1

# 1 Introduction

---

## 1.1 2901300 Flat Panel PC Overview

The 2901300 flat panel PC is a flexible, multi-functional flat panel PC that can be applied in diverse operational environments and implemented in multi-faceted applications. The 2901300 comes fully kitted with a high-performance motherboard, CPU, power supply unit and a host of other peripheral interface connectors. The 2901300 is designed for ease of use and easy installation.

### 1.1.1 2901300 Model Variation

Four 2901300 models are available. The models are listed in **Table 1-1**.

2901300	CPU	Socket/ On board	Resistive touch screen
2901300A	Pentium M / Celeron M FSB 400 MHz	Socket 479	No
2901300B	Pentium M / Celeron M FSB 400 MHz	Socket 479	Yes
2901300C	ULV Celeron M 800 MHz	On board	No
2901300C	ULV Celeron M 800 MHz	On board	Yes

**Table 1-1: 2901300 Model Variation**

### 1.1.2 2901300 Flat Panel PC Applications

The 2901300 flat panel PC is designed for rigorous industrial environments where it may be exposed to both heat and moisture. Its durability and strength also makes it an ideal choice for public access computers. Some possible applications include:

- f* Automated manufacturing processes
- f* Public information gathering point

### 1.1.3 2901300 Flat Panel PC Features

Some of the features of the 2901300 flat panel PC include:

- f* Intel Pentium M / Celeron M mobile CPU support
- f* Low power consumption and thermal distribution
- f* Dual DDR memory DIMM support up to 2GB SDRAM

- f* Aluminum die-casting IP65, high brightness 15" industrial panel
- f* Serial ATA interface support
- f* Dual 10/100/Gigabit Ethernet support
- f* Simplified installation process
- f* RoHS compliance

## 1.2 2901300 External Overview

### 1.2.1 General Description

The 2901300 flat panel PC is a rectangular cubic structure that comprises of a screen, rear panel, top panel, bottom panel and two side panels (left and right). An aluminum frame surrounds the front screen. The rear panel provides screw holes for a wall-mounting bracket, and an arm mounting interface. The top panel and the side panel provide retention screw holes for panel mounting and rack/cabinet installation. The right panel also provides access to a CD drive. The bottom panel provides access to external interface connectors that include LAN, USB 2.0, audio and serial port connectors.

### 1.2.2 Front Panel

The front side of the 2901300 is a flat panel 15" TFT LCD screen surrounded by an aluminum frame.

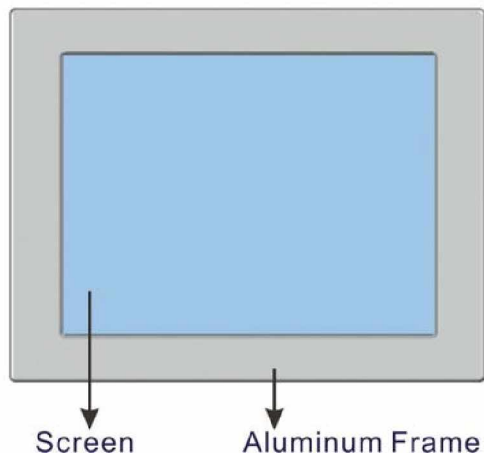

Figure 1-1: 2901300 Front View

### 1.2.3 Rear Panel

The rear panel provides access to four retention screw holes that support a wall-mounting bracket. The retention screw holes are circled in **Figure 1-2**.

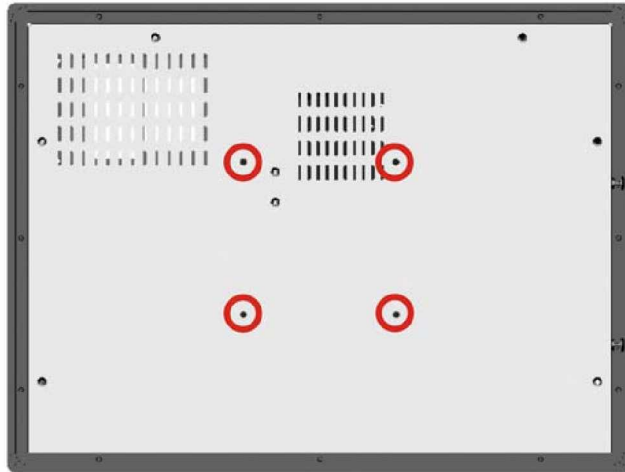

Figure 1-2: 2901300 Rear View

### 1.2.4 Top Panel

The top panel provides access to two retention screw holes that support to secure the back cover to the chassis. The retention screw holes are circled in **Figure 1-3** below.

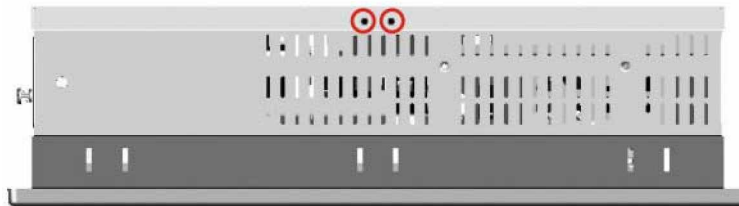

Figure 1-3: 2901300 Top View

### 1.2.5 2901300 Bottom Panel

The bottom panel shown in **Figure 1-4** has the following interfaces:

- f 1 x Power supply unit (PSU) plug socket
- f 3 x Audio jacks
- f 1 x Power switch
- f 1 x VGA connector
- f 5 x Serial port (COM) connectors
- f 4 x USB 2.0 connectors
- f 1 x DVI connector
- f 2 x PS/2 keyboard/mouse connectors
- f 2 x RJ-45 connectors
- f 1 x Compact Flash slot

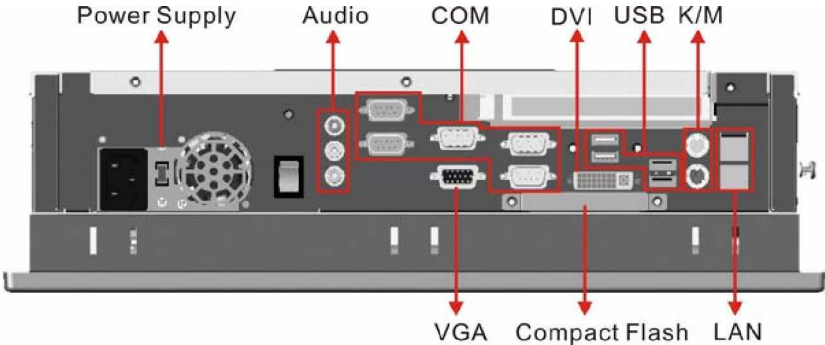

Figure 1-4: Bottom View

1.2.6 Right Side Panel

The right side panel provides access to the PCMCIA card door and a fan ventilation vent. (See Figure 1-5)

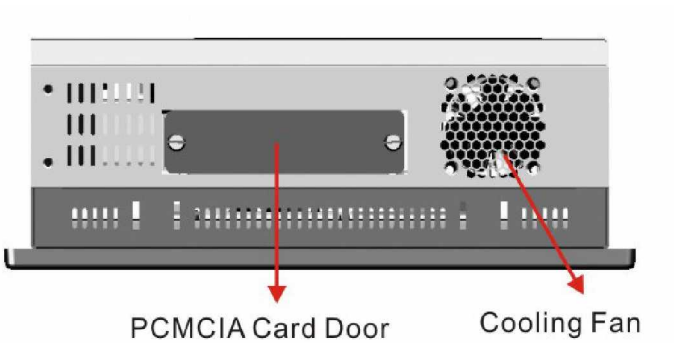
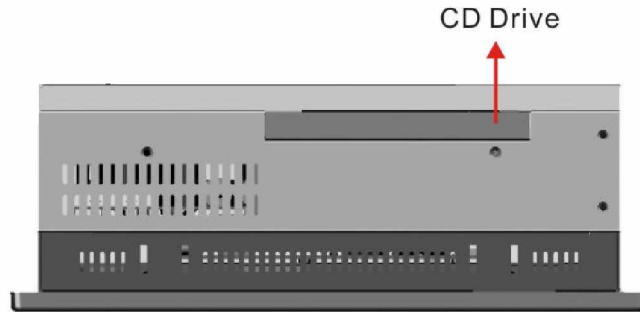

Figure 1-5: Right View

### 1.2.7 Left Side Panel

The left side panel provides access to the CD drive. (See **Figure 1-6**)



**Figure 1-6: Left View**

### 1.2.8 Frame

An aluminum frame surrounds the 15" TFT LCD screen. This aluminum frame has 12 small screw holes that are used when the flat panel PC is mounted into a panel. These screws are circled in **Figure 1-7**.

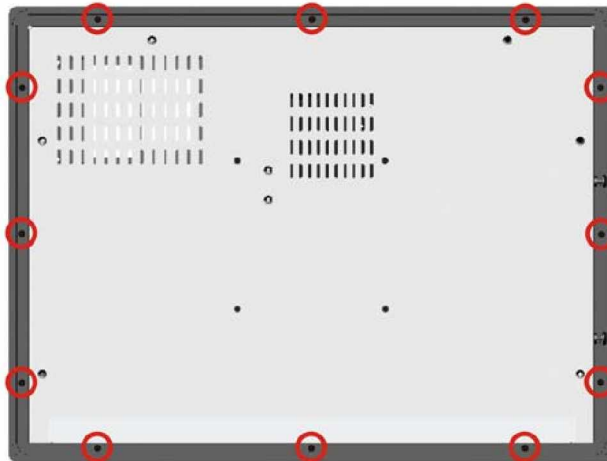

**Figure 1-7: Frame Rear View (12 panel mount retention screws)**

## 2901300 Flat Panel PC

### 1.3 2901300 Internal Overview

The 2901300 internal components are configured in a three level format. An elevated platform on the right side of the chassis supports a HDD and a CD drive. On the second level, below the elevated platform, are a motherboard and a PSU module. The motherboard and the PSU module are installed on a metal sheet that protects the rear of the 15" TFT LCD screen. Below the metal sheet is a circuit board that is connected to the screen and the motherboard. This PCB is found on the right side of the chassis below the elevated platform.

### 1.4 2901300 Specifications

#### 1.4.1 Preinstalled Hardware Components

The 2901300 flat panel PC has the following preinstalled components:

- f* 1 x Motherboard
- f* 1 x 15" TFT LCD screen
- f* 1 x Power supply unit (PSU)
- f* 1 x PCI riser card

The technical specifications for these components and the system are shown in the sections below.

#### 1.4.2 System Specifications

The technical specifications for the 2901300 system are listed in **Table 1-2**.

SPECIFICATION	DETAIL
Front Panel	Aluminum Front Panel
Chassis	Heavy-duty Steel
LCD Panel	15" TFT LCD
Resolution	1024 x 768 (XGA)
Brightness	350 cd/m <sup>2</sup>
LCD MTBF	50,000 hrs
Backlight MTBF	30,000 hrs

<b>Touch Screen</b>	Optional Resistive type touch screen with RS-232 interface
<b>Display</b>	Support Dual Display (CRT, DVI)
<b>Add-On Card (Optional)</b>	Supports PCI, Mini PCI, CFII & PCMCIA
<b>Drive Bay</b>	One slim type CD-ROM bay
<b>Power Supply</b>	150W AT Power
<b>Mounting Feature</b>	Panel, Arm, Wall, or Rack
<b>Color</b>	Silver (PANTONE PMS-8001)
<b>Operating Temperature</b>	0~50°C
<b>Relative Humidity</b>	5 ~ 95%, non-condensing
<b>Vibration</b>	5 - 17Hz, 0.1" double amplitude displacement. 17 - 640Hz, 1.5G acceleration, peak to peak.
<b>Shock</b>	10G Acceleration, peak to peak (11ms)
<b>Dimension</b>	410(W) x 309(H) x 110(D) mm
<b>Environment</b>	RoHS Compliant

Table 1-2: 2901300 Specifications

### 1.4.3 2901300 Motherboard Specifications

The 2901300 comes with an 2804150 motherboard. The technical specifications of the motherboard are listed in **Table 1-3**.

<b>SPECIFICATION</b>	<b>DETAIL</b>
<b>CPU</b>	Onboard ULV Intel Celeron M 800MHz or Socket-479 base Intel Pentium M / Celeron M, FSB 400 MHz
<b>Northbridge</b>	855GME
<b>Southbridge</b>	ICH4
<b>FSB</b>	400 MHz
<b>Memory</b>	2 x DDR 266/333 DIMM sockets, total up to 2GB
<b>BIOS</b>	AMI BIOS Label
<b>Graphics</b>	CRT integrated in Intel 855GME
	DVI integrated in Silicon image SiL164
	LVDS Dual 18-bit TTL LCD integrated in Intel 855GME

<b>SSD</b>	1 x CFII
<b>Audio</b>	AC'97 (ALC655) supports SPK-OUT, MIC-IN, LINE-IN, LINE-OUT
<b>Ethernet</b>	2x GbE (Realtek RTL8110S)
<b>COM</b>	1x RS-232/422/485 (detected by jumper) 5x RS-232
<b>USB 2.0</b>	6 x USB 2.0 connects, 4 by external connector and 2 by 2x4 pin header with housing
<b>Drive Interfaces</b>	2 x 44pin IDE
<b>LPT</b>	1 x LPT connector
<b>KB/ MS</b>	2 x PS/2 mini DIMM connector
<b>Super I/O</b>	ITE IT8712F-A/IXS
<b>Extension</b>	1x PCI
<b>Digital I/O</b>	4 input/ 4 output DIO 2x5 pin header connector without housing
<b>PCMCIA</b>	1 x PCMCIA slot

Table 1-3: Motherboard Specifications

#### 1.4.4 Flat Panel Screen

The 2901300 comes with a 15" TFT LCD monitor at the front of the flat panel PC (see **Figure 1-1**). The specifications for the LCD monitor are shown in **Table 1-4** below.

<b>SPECIFICATION</b>	<b>DETAILS</b>
<b>Model</b>	<b>AUO-G150XG01</b>
<b>Size</b>	<b>15"</b>
<b>Resolution</b>	<b>XGA (1024 x 768)</b>
<b>Active Area (mm)</b>	<b>304.1 x 228.1</b>
<b>Pixel Pitch (mm)</b>	<b>0.297</b>
<b>Mode</b>	<b>TN</b>
<b>Number of Colors</b>	<b>262K</b>
<b>Color Saturation (%)</b>	<b>60</b>
<b>View Angel (H/V)</b>	<b>130/120</b>

<b>Brightness (cd/m<sup>2</sup>)</b>	<b>350</b>
<b>Contrast Ratio</b>	<b>500:1</b>
<b>Response Time (ms) (at 25°C)</b>	<b>12</b>
<b>Power Consumption (W)</b>	<b>11.5</b>
<b>Interface</b>	<b>1ch LVDS</b>
<b>Supply Voltage (V)</b>	<b>3.3</b>
<b>Backlight</b>	<b>2 CCFL</b>
<b>Outline Dimensions (mm)</b>	<b>326.5 x 253.5 x 12.0</b>
<b>Weight (g)</b>	<b>1100</b>

**Table 1-4: 15" TFT LCD Monitor Specifications**

#### 1.4.5 Power Supply Unit (PSU)

The 2901300 flat panel PC comes with a 150W, RoHS compliant PSU. The PSU has an MTBF greater than 100,000 hours. The maximum power output for the PSU is shown below.

- f +3.3V and +5V Combined Power 85W MAX
- f +3.3V ,+5V and +12V Combined Power 150W MAX



#### **WARNING:**

Under no circumstances is the PSU case to be opened. The PSU module is not user serviceable and there are dangerous high-voltages inside the case. If there are any problems with the PSU module, please contact the dealer or reseller immediately.

---

The specifications for the PSU module are shown in (Table 1-5).

## 2901300 Flat Panel PC

<b>INPUT</b>	<b>Voltage</b>	AC90V ~ 265VAC Full Range				
	<b>Frequency</b>	47 ~ 63Hz				
	<b>Input Current</b>	4A(RMS)@115VAC 2A(RMS)@230VAC				
	<b>Inrush Current</b>	50A Max for 115VAC 80A Max for 230VAC				
<b>OUTPUT</b>	<b>Voltage (V)</b>	+3.3V	+5V	+12V	-12V	5VSB
	<b>Max. Load (A)</b>	10A	14A	4.2A	0.3A	2A
	<b>Min. Load (A)</b>	0.3A	1A	0.3A	0A	0A
	<b>Ripple and Noise (mV)</b>	50mV	50mV	120mV	120mV	50mV
	+3.3V & +5V ≤ 85W					
<b>GENERAL</b>	<b>Watt</b>	150W				
	<b>PFC</b>	Active				
	<b>Hold-up time</b>	17ms minimum				
	<b>Efficiency</b>	68%				
	<b>MTBF</b>	100,000hrs				
	<b>Temperature</b>	0~35° C (Operating) -20~80° C (Storage)				
	<b>Dimension</b>	150mm (W) x 81.5mm(H) x 40mm (D)				

**Table 1-5: Power Supply Specifications**

### 1.5 OEM Customizations

There are a number of OEM customizations available to users. These include the following:

- f* Preinstalled PCMCIA card
- f* Preinstalled SATA drives
- f* Memory chips with different sizes
- f* Different CPU
- f* Preinstalled HDD
- f* Preinstalled CD drive

To implement any of the above OEM customizations please contact a GAI sales representative directly.

## 1.6 Dimensions

The dimensions of the 2901300 flat panel PC are shown in **Figure 1-8** below.

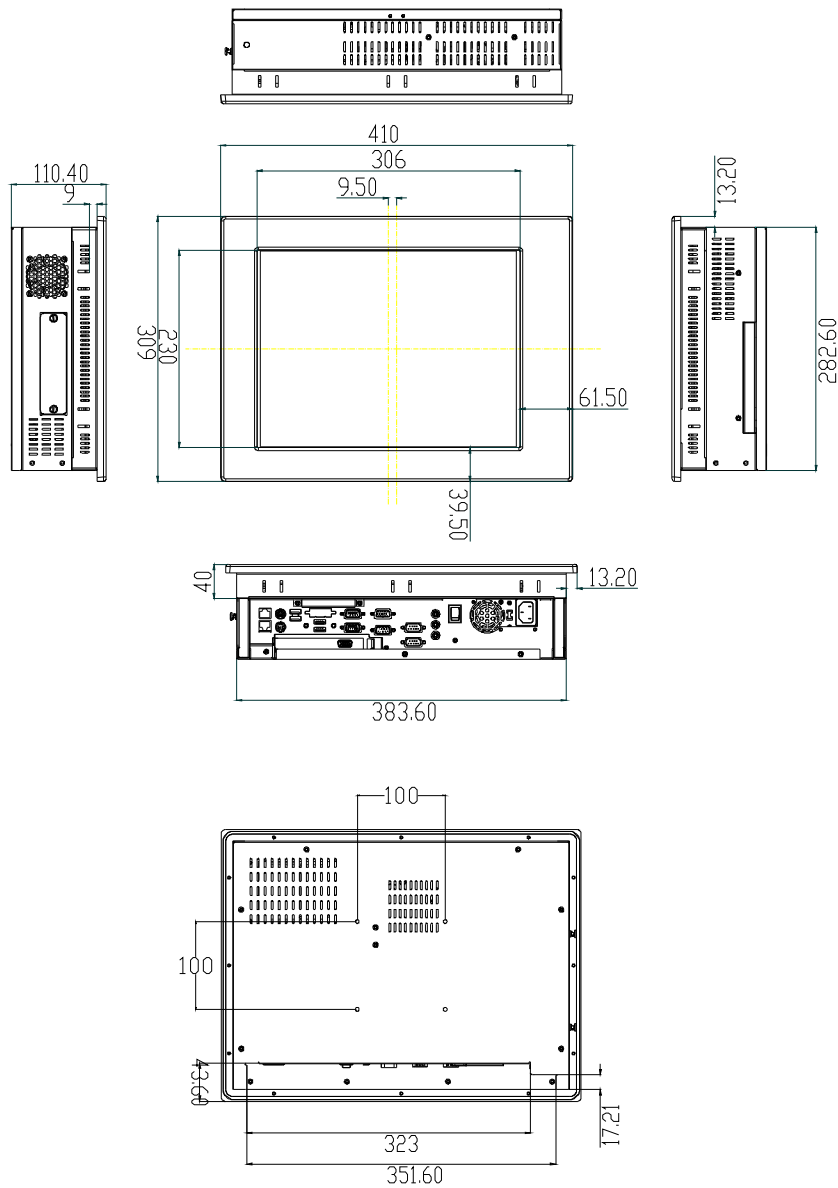

**Figure 1-8: Dimensions (units in mm)**

Chapter  
2

# 2804150 Motherboard

---

## 2.1 Introduction

The 2901300 flat screen PC contains an 2804150 motherboard. The motherboard is the heart of any computer and is responsible for transmitting, receiving and processing data as well as driving the different onboard devices. This chapter gives a brief introduction to the 2804150 motherboard. For more complete details on the connectors and the different implementations of the 2804150, please refer to the 2804150 user guide.

## 2.2 CPU Support

The 2804150 installed in the 2901300 supports socket 479, Intel Pentium M / Celeron M FSB 400 MHz CPU and onboard ULV Intel Celeron M 800MHz CPU.

## 2.3 Onboard Chipsets

### 2.3.1 Northbridge and Southbridge Chipsets

The following chipsets are preinstalled on the board:

- f* **Northbridge:** Intel 855GME
- f* **Southbridge:** ICH4

The following two sections (**Section 2.3.2** and **Section 2.3.3**) list some of the features of the 855GME and the ICH4 chipsets. For more information on these two chipsets please refer to the Intel website.

### 2.3.2 855GME Northbridge Chipset

The 855GME northbridge chipset comes with the following features:

- f* 400 MHz system bus delivers a high-bandwidth connection between the processor and the platform
- f* Integrated graphics utilizing Intel® Extreme Graphics 2 technology
- f* AGP 4X support
- f* Three USB host controllers provide high-performance peripherals with 480 Mbps of bandwidth, while enabling support for up to six USB 2.0 ports.
- f* The latest AC '97 implementation delivers 20-bit audio for enhanced sound quality and full surround sound capability

- f* LAN Connect Interface (LCI) provides flexible network solutions such as 10/100 Mbps Ethernet and 10/100 Mbps Ethernet with LAN manageability
- f* Dual Ultra ATA/100 controllers, coupled with the Intel® Application Accelerator support faster IDE transfers to storage devices
- f* The Intel Application Accelerator software provides additional performance over native ATA drivers by improving I/O transfer rates and enabling faster O/S load time, resulting in accelerated boot times
- f* Communication and Network Riser (CNR) offers flexibility in system configuration with a baseline feature set that can be upgraded with an audio card, modem card, or network card
- f* Error Correcting Code (ECC) support in integrated graphics mode only

### 2.3.3 ICH4 Southbridge Chipset

The ICH4 southbridge chipset comes with the following features:

- f* PCI Local Bus Specification, Revision 2.2-compliant with support for 33 MHz PCI operations.
- f* ACPI Power Management Logic Support
- f* Enhanced DMA controller, Interrupt controller, and timer functions
- f* Integrated IDE controller supports Ultra ATA100/66/33
- f* USB host interface with support for 6 USB ports; 3 UHCI host controllers; 1 EHCI high-speed
- f* USB 2.0 Host controller
- f* Integrated LAN controller
- f* System Management Bus (SMBus) Specification, Version 2.0 with additional support for I2C devices
- f* Supports Audio Codec '97, Revision 2.3 specification
- f* Low Pin Count (LPC) interface
- f* Firmware Hub (FWH) interface support
- f* Alert On LAN\* (AOL) and Alert On LAN 2\* (AOL2)

## 2.4 Graphics Support

The graphics features listed below are all integrated on the 855GME northbridge chipset.

### 2.4.1 Display

- f* Analog display support
- f* Dual independent pipe support
  - Concurrent: different images and native display timings on each display device
  - Simultaneous: same images and native display timings on each display device
- f* DVO (DVOB and DVOC) support
  - Digital video out ports DVOB and DVOC with 165 MHz dot clock on each 12-bit interface; two 12-bit channels can be combined to form one dual-channel 24-bit interface with an effective dot clock of 330 MHz
  - Compliant with DVI Specification 1.0
- f* Dedicated Local Flat Panel (LFP) LVDS interface

### 2.4.2 Internal Graphics Features

- f* Core frequency
  - Display core frequency of 133 MHz
  - Render core frequency of 133 MHz

### 2.4.3 Intel® Embedded Graphics Drivers

- f* Graphics interface support
  - GDI and DirectX\* DirectDraw\* with overlay for Windows\* XP, Windows\* 2000, and Windows\* Embedded XP
  - XFree86\*, XAA, and Xv for Linux\*
- f* Multi-monitor support
  - Multiple programmable configurations
  - Dual independent display
  - DVO device support/TV-Out
- f* Dynamic display-mode support

- User definable and extensible
- f* Embedded video BIOS
  - Common port interface support
  - Full VGA compatibility

## 2.5 Peripheral Device Interfaces, Connectors, and Slots

The peripheral device connectors, interfaces and slots on the 2804150 motherboard are listed in the sections below.

### 2.5.1 OEM Options

Many of the peripheral device connectors listed below are not connected to any devices. These connectors are reserved for OEM customizations. For a customized option, please contact a GAI sales representative.

### 2.5.2 Internal Slots

The slots listed below can all be found on the 2804150 motherboard.

- f* 2 x 184 pin DDR-SDRAM sockets
- f* 1 x PCI slot
- f* 1 x PCMCIA slot

### 2.5.3 Internal Peripheral Device Connectors

The peripheral device connectors listed below are located on the 2804150 motherboard. Pinouts for these connectors can be found in **Appendix A**.

- f* 1 x Front panel connector
- f* 1 x Disk LED connector
- f* 1 x Power button connector
- f* 1 x System panel connector
- f* 2 x 44-pin IDE connectors
- f* 1 x Compact Flash Connector
- f* 3 x Serial port connectors
- f* 4 x USB2.0 connectors
- f* 1 x LCD LVDS connector

<i>f</i>	1 x Power inverter connector
<i>f</i>	1 x ATX power connector
<i>f</i>	3 x Cooling fan connectors
<i>f</i>	1 x 8 bits GPIO connector
<i>f</i>	1 x Audio connector
<i>f</i>	1 x IR interface connector
<i>f</i>	1 x PCMCIA connector

### 2.5.4 External Peripheral Device Connectors

The peripheral device connectors listed below are located on the rear panel of the 2804150 motherboard. Pinouts for these connectors can be found in **Appendix A**.

<i>f</i>	1 x Audio connector
<i>f</i>	1 x COM port jumper
<i>f</i>	1 x DVI-I connector
<i>f</i>	3 x Serial port connectors
<i>f</i>	1 x CRT connector
<i>f</i>	1 x PS/2 keyboard connector
<i>f</i>	1 x PS/2 mouse connector
<i>f</i>	2 x USB 2.0 connectors
<i>f</i>	2 x LAN RJ-45 connectors

## 2.6 PCI Riser Card

A PCI riser card is preinstalled into the PCI slot. The riser card consists of the following components:

<i>f</i>	2 x SATA drive connectors
<i>f</i>	1 x Ali chipset for SATA RAID configuration

These configurations are OEM optimizations. Please contact a GAI sales representative to have these configuration options.

Chapter

3

# Installation and Configuration

---

### 3.1 Installation Precautions

When installing the 2901300, please follow the precautions listed below:

- f* **Power turned off:** When installing the 2901300 make sure the power is off. Failing to turn off the power may cause severe injury to the body and/or damage to the system.
- f* **Certified Engineers:** Only certified engineers should install and modify onboard functionalities.
- f* **Mounting:** The 2901300 is a heavy device. When mounting the system onto a rack, panel, wall or arm please make sure that at least two people are assisting with the procedure.
- f* **Anti-static Discharge:** If a user open the rear panel of the 2901300, to configure the jumpers or plug in added peripheral devices, ground themselves first and wear an anti-static wristband.

### 3.2 Preinstalled Components

The following components are all preinstalled.

- f* Motherboard
- f* 15" TFT LCD touch screen
- f* PSU module (150W, 1U)
- f* Power switch
- f* PCI riser card
- f* Inverter board

Preinstalled OEM customizations may include the following.

- f* HDD
- f* CD drive
- f* PCMCIA card
- f* SATA drives
- f* An additional DIMM

Removing and reinstallation of some of the components are described in **Chapter 4**.

### 3.3 Installation and Configuration Steps

The following installation steps must be followed.

**Step 1:** Unpack the 2901300.

**Step 2:** Set the jumper settings

**Step 3:** Mount the 2901300 flat panel PC.

**Step 4:** Connect peripheral devices to the bottom panel of the 2901300

**Step 5:** Configure the system

### 3.4 Unpacking

When unpacking the 2901300 flat panel PC, please check the following:

**Step 1:** Make sure the 2901300 is not damaged.

**Step 2:** Make sure the pre-packed components listed below are present:

- 1 x Carton
- 1 x Power cable
- 1 x IDE cable
- 1 x CPU cooler
- 1 x Driver CD
- 1 x Supplementary screw set (screws can be used for wall-mounting).

### 3.5 Jumper Settings

---



**NOTE:**

These jumper settings and the jumper locations are described in detail in the User Manual that came with the 2804150 motherboard. Please refer to this manual for a more detailed understanding of the jumper settings

---

**NOTE:**

A jumper is a metal bridge that is used to close an electrical circuit. It consists of two metal pins and a small metal clip (often protected by a plastic cover) that slides over the pins to connect them. To CLOSE/SHORT a jumper means connecting the pins of the jumper with the plastic clip and to OPEN a jumper means removing the plastic clip from a jumper.

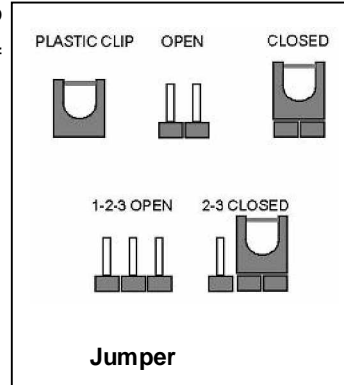

The 2804150 comes with four jumpers. They are listed below.

- f* Clear CMOS
- f* CD Card Setup
- f* LCD Voltage Setup
- f* COM Port Jumper Settings

### 3.5.1 Remove the Back Cover

The back cover is secured to the chassis with twelve retention screws, eight on the rear panel, two on the bottom panel and two on the top panel. (See **Figure 3-1** and **Figure 3-2**) Remove the twelve retention screws and lift the cover off the 2901300.

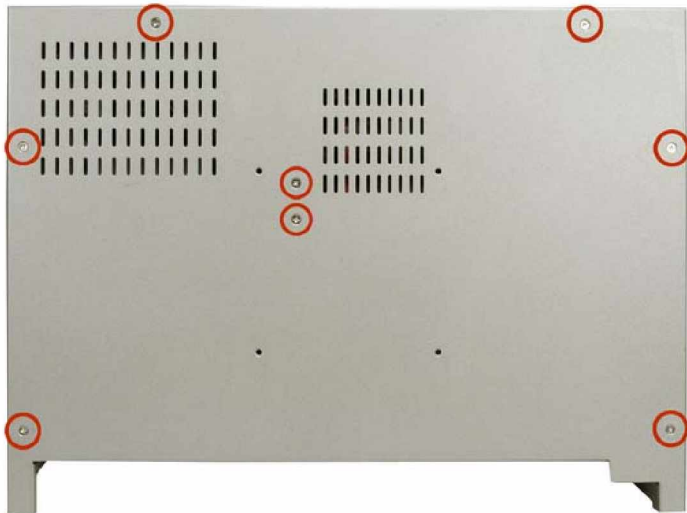

Figure 3-1: Rear Cover Retention Screws (Real Panel)

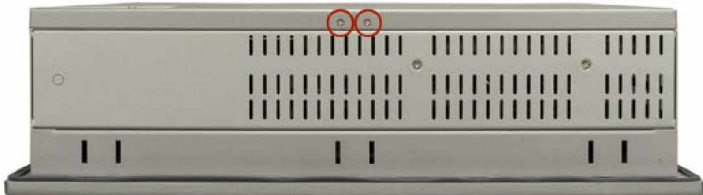

Figure 3-2: Rear Cover Retention Screws (Top Panel)



Figure 3-3: Rear Cover Retention Screws (Bottom Panel)

### 3.5.2 JP2: Clear CMOS Setup

If the motherboard fails to boot due to improper BIOS settings, use this jumper to clear the CMOS data and reset the system BIOS information. To do this, use the jumper cap to close pins 2 and 3 for a few seconds then reinstall the jumper clip back to pins 1 and 2.

If the “CMOS Settings Wrong” message displays during the boot up process, try to correct the fault by pressing the F1 to enter the CMOS Setup menu. Then do one of the following:

- f* Enter the correct CMOS setting
- f* Load Optimal Defaults
- f* Load Failsafe Defaults.

After one of the above has been done, save the changes and exit the CMOS Setup menu.

JP2	DESCRIPTION
1 - 2	Normal (Default)
2 – 3	Clear CMOS

**Table 3-1: Clear CMOS Jumper Settings**

### 3.5.3 JP4: CF Card Setup

The CF Card Setup jumper configures a CD card as either the slave or the master.

JP4	DESCRIPTION
Open	Slave(Default)
Close	Master

**Table 3-2: CF Card Setup Jumper Settings**

### 3.5.4 JP5: LCD Voltage Setup



**WARNING:**

Do not change this voltage. This voltage has been preset and is compatible with the currently installed 15” TFT LCD screen. Change this jumper setting may cause damage to the system.

The LCD Voltage Setup jumper sets the voltage for the LCD screen. This setting **MUST NOT** be changed.

JP5	DESCRIPTION
1-2	3.3V (Default)
2-3	5V

Table 3-3: LCD Voltage Setup Jumper Settings

### 3.5.5 CN13: COM Port Jumper Setting

The COM Port jumper configures the COM1, COM2 and COM3 serial ports.

CN13	DESCRIPTION		DESCRIPTION
1-3	COM1 pin9 has 5V	2-4	COM2 pin9 has 5V
3-5	COM1 pin9 has 12V	4-6	COM2 pin9 has 12V
7-9	COM3 pin9 has 12V	8-10	COM3 as RS-232
9-11	COM3 pin9 has 5V	10-12	COM3 as RS-422/485
			RS-422: Pin 13, 14, 15, 16 left open
			RS-485: Pin13 (TX3+) and Pin14 (RX3+) are shorted; Pin15 (TX3-) and Pin16 (RX3-) are shorted.

Table 3-4: COM Port Jumper Settings



#### NOTE:

1. There are two "COM3" connectors on the 2804150 motherboard. One is a 14-pin header. The other is a D-SUB 9-pin. Use the D-SUB connector only if the user prefer COM3 to operate in the RS-232 mode.
2. To facilitate access to the serial port jumper configuration pins, CN13 is provided as a pin jumper block on the I/O panel. The location of CN13 is diagrammed below:

## 3.6 Mounting the System

---



### WARNING:

When mounting the 2901300 flat panel PC onto a arm, onto the wall or onto a panel, it is better to have more than one person to help with the installation to make sure the 2901300 does not fall down and get damaged.

---

The three methods of mounting the 2901300 are listed below.

- f* Wall mounting
- f* Panel mounting
- f* Arm mounting

The three mounting methods are described below.

### 3.6.1 Wall Mounting

To mount the 2901300 flat panel PC onto the wall, please follow the steps below.

**Step 1:** Attach the wall-mounting bracket to the wall.

1. Select the location on the wall.
2. Carefully mark the four locations on the wall where the retention screws for the wall-mounting bracket to be inserted.
3. Drill the holes.
4. Align the wall-mounting bracket screw holes to those on the wall.
5. Insert the screws into the four retention screw holes (see **Figure 3-4**).

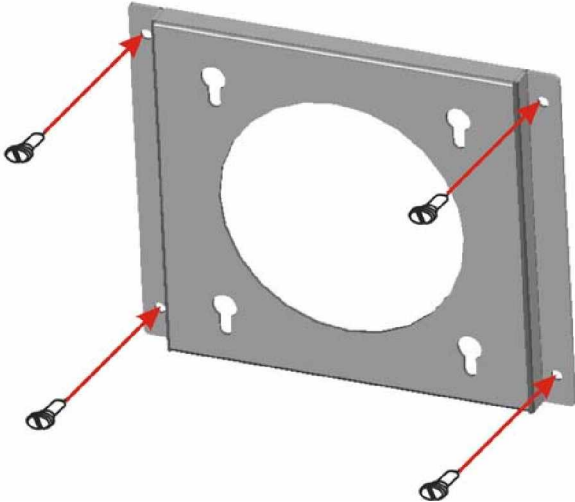

Figure 3-4: Wall-mounting Bracket

**Step 2:** Insert the four screws into the four screw holes on the rear cover of 2901300 (see Figure 3-5). Make sure a part of the screw protrudes out of the flat panel PC rear cover and can be inserted into the bracket.

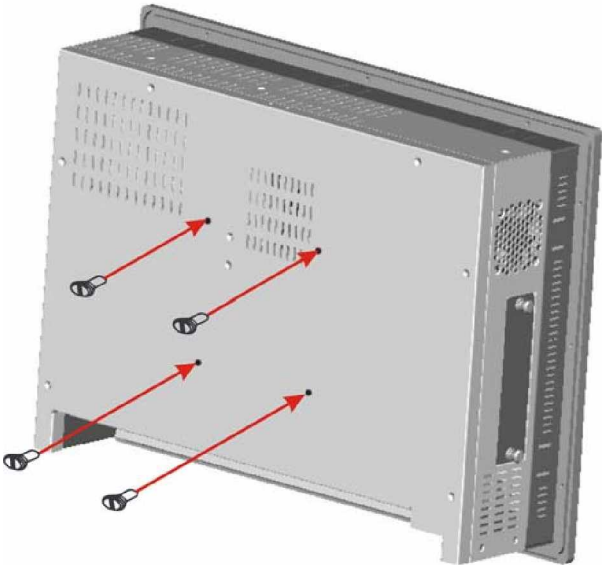

Figure 3-5: Chassis Support Screws

**Step 3:** Slide the 2901300 flat panel PC through the top of the wall-mounting

bracket and insert the four screws protruding from the rear panel of the panel PC into the corresponding spaces on elevated part of the wall-mounting bracket (see **Figure 3-6**).



**NOTE:**

In the diagram below the bracket is already installed on the wall.

---

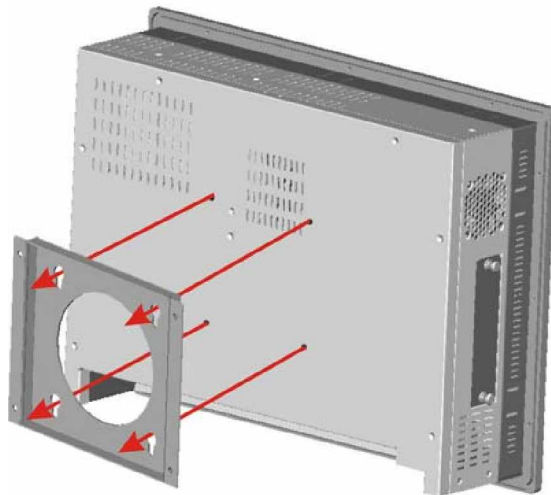

**Figure 3-6: Mount the Chassis**

### 3.6.2 Panel Mounting

To mount the 2901300 flat panel PC into a panel, please follow the steps below.

**Step 1:** Select the position in the panel to mount the 2901300.

**Step 2:** Cut out a section from the panel that corresponds to the dimensions of the 2901300 flat panel PC chassis. The panel section that is cut out must be smaller than the size of the aluminum frame that surrounds the 15" TFT LCD panel but just large enough for the chassis to fit through (see **Figure 3-7**).

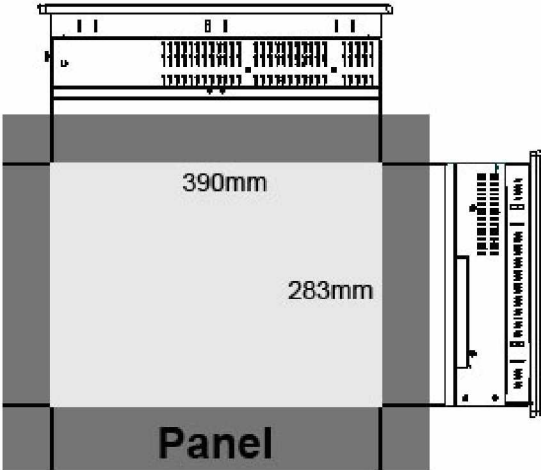

Figure 3-7: Cut the Panel

**Step 3:** Slide the 2901300 flat panel computer through the previously cut hole. The chassis at the rear of the 2901300 flat panel should slide easily through the hole. Only stop sliding the panel through the hole when the back of the front aluminum frame is flush against the panel.

**Step 4:** Insert the panel mounting clamps into the pre-formed holes along the edges of the chassis, behind the aluminum frame. There are a total of 12 panel mounting clamps.

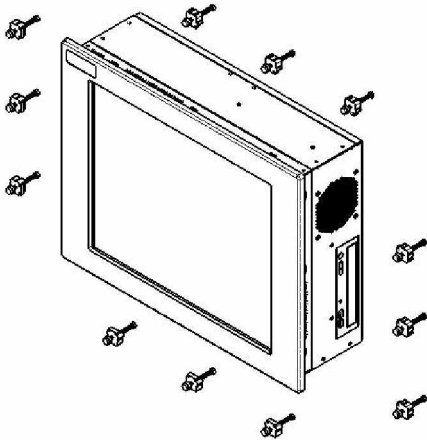
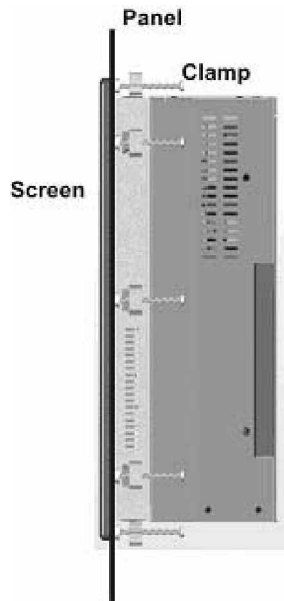

Figure 3-8: Panel Mounting Clamp Positions

**Step 5:** Tighten the screws that pass through the panel mounting clamps until the plastic caps at the front of all the screws are firmly secured to the panel (**Figure 3-9**).



**Figure 3-9: Tighten the Panel Mounting Clamp Screws**

### 3.6.3 Arm Mounting

The 2901300 is VESA (Video Electronics Standards Association) compliant and can be mounted on an arm with a 100mm interface pad. To mount the 2901300 on an arm, please follow the steps below.

**Step 1:** The arm is a separately purchased item. Please correctly mount the arm onto the surface it uses as a base. To do this, refer to the installation documentation that came with the mounting arm.



**NOTE:**

When purchasing the arm please ensure that it is VESA compliant and that the arm has a 100mm interface pad. If the mounting arm is not VESA

---

---

compliant it cannot be used to support the 2901300 flat panel PC.

---

**Step 2:** Once the mounting arm has been firmly attached to the surface, lift the 2901300 flat panel PC onto the interface pad of the mounting arm.

**Step 3:** Align the retention screw holes on the mounting arm interface with those in the 2901300 flat panel PC. The 2901300 flat panel PC arm mount retention screw holes are shown in **Figure 3-10**.

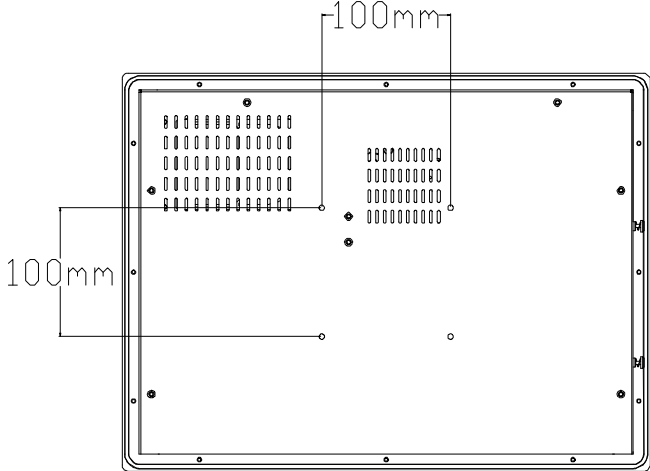

**Figure 3-10: Arm Mount Retention Screw Holes**

**Step 4:** Secure the 2901300 to the interface pad by inserting four retention screws through the bottom of the mounting arm interface pad and into the 2901300 flat panel PC.

## 3.7 Rear Panel Connectors

### 3.7.1 LCD Panel Connection

To connect the 2901300 flat panel PC to a second monitor, a conventional CRT VGA monitor connector is located on the bottom panel. This panel is a 15-pin, female D-SUB connector.



#### NOTE:

To use the dual screen option, please configure this option in the **Intel® Extreme Graphics** configuration program. To do this, after Windows has loaded, open the **Control Panel**, locate the **Intel® Extreme Graphics** icon, click on it. Once open, an option for **Multiple Display** is available. Select this option and select notebook as the primary device.

---

### 3.7.2 Ethernet Connection

The two rear panel RJ-45 connectors can be connected to an external LAN and provide internet connectivity to the flat panel PC.

### 3.7.3 USB Connection

The rear panel USB connectors provide easier and quicker access to external USB devices. The rear panel USB connector is a standard connector and can easily be connected to other USB devices.

### 3.7.4 Keyboard and Mouse Connection

Two PS/2 connectors on the bottom panel facilitate the connection of a mouse and a keyboard. To connect either device, plug the PS/2 connector at the end of the device (keyboard or mouse) cable into the PS/2 connector on the bottom panel.

Chapter

4

# 4 System Maintenance

---

## 4.1 System Maintenance Introduction

The following system components can fail.

- f* CPU cooling fan
- f* PSU module
- f* DIMM module
- f* Motherboard

If these components fail they must be replaced. Please contact the system reseller or vendor to purchase the replacement parts. Replacement instructions for the above listed components are described below.

## 4.2 Motherboard Replacement

A user cannot replace a motherboard. If the motherboard fails it must be shipped back to GAI to be replaced. If the system motherboard has failed, please contact a GAI sales person directly.

## 4.3 Back Cover Removal and Elevated Platform Detachment

### 4.3.1 Back Cover Removal



**WARNING:**

**BEFORE REMOVING THE BACK COVER, MAKE SURE THE POWER IS OFF.** Failing to do so may lead to severe damage of 2901300 and injury to the body.

---

---



**WARNING:**

**PLEASE TAKE ANTISTATIC PRECAUTIONS WHEN WORKING WITH THE INTERNAL COMPONENTS.** The interior of the 2901300 contains

---

---

very sensitive electronic components. These components are easily damaged by electrostatic discharge (ESD). Before working with the internal components make sure all the anti-static precautions described earlier have been observed.

---

To replace any of the following components,

- f* CPU cooling fan
- f* DIMM module
- f* PSU module

The back cover of the 2901300 must be removed. To remove the back cover, please follow the steps below.

- Step 1:** Remove the 2901300 from the wall (if it was mounted on the wall) or the panel (if it was mounted in the panel). If it was mounted on the wall, remove the wall-mounting bracket secured to the back rear previously.
- Step 2:** The back cover is secured to the chassis with twelve retention screws, eight on the rear panel, two on the bottom panel and two on the top panel. (See **Figure 4-1** and **Figure 4-3**) Remove the twelve retention screws and lift the cover off the 2901300.

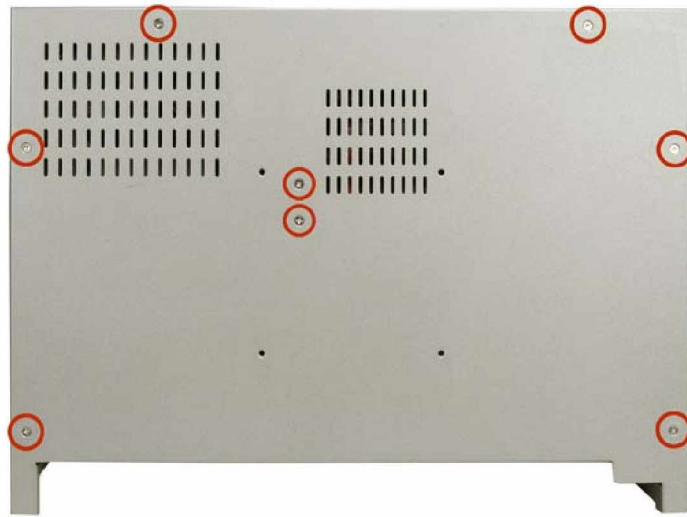

Figure 4-1: Rear Cover Retention Screws (Real Panel)



Figure 4-2: Rear Cover Retention Screws (Top Panel)



Figure 4-3: Rear Cover Retention Screws (Bottom Panel)

### 4.3.2 Detaching the Elevated Platform

To replace PSU module, the back cover of the 2901300 must be removed and the elevated platform must be detached. Back cover removal is discussed above (see **Section 4.3.1**). To detach the elevated platform, please follow the steps below.

**Step 1:** The elevated platform is located on the left side of the 2901300 and supports the CD drive and the HDD.

**Step 2:** The elevated platform is secured to the chassis with five retention screws, two on the top panel (see **Figure 4-4**), two on the right panel (see **Figure 4-5**) and one on the bottom panel (see **Figure 4-6**). Remove these five retention screws.



Figure 4-4: Elevated Platform Retention Screws (Top Panel)

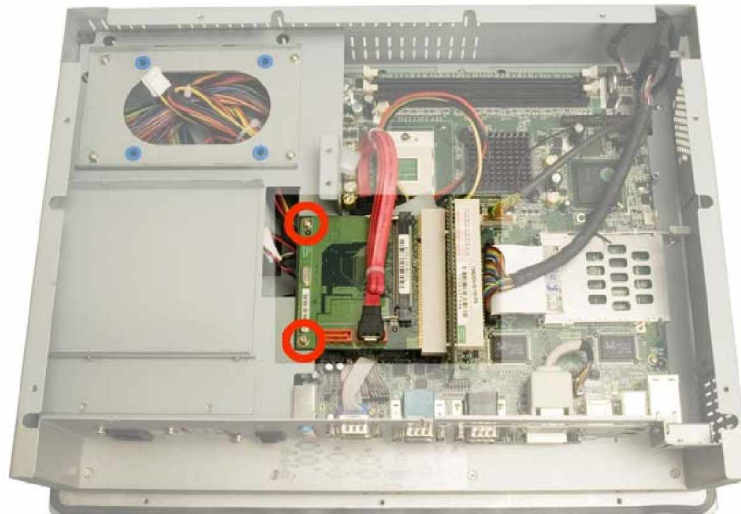

Figure 4-5: Elevated Platform Retention Screws (Right Panel)



**Figure 4-6: Elevated Platform Retention Screws (Bottom Panel)**

**Step 3:** A PCI riser card is attached to the side of the elevated platform with two retention screws. Remove the two retention screws and the PCI riser card from the chassis.



**Figure 4-7: PCI Riser Card Retention Screws**

## 4.4 DIMM Replacement

To install the DIMM please follow the steps below.

**Step 1:** Remove the back cover. See **Section 4.3.1** above.

**Step 2:** Locate the DIMM. It is on the motherboard near the top of the 2901300 flat screen PC. Push the white clips on the side of the DIMM down. The DIMM is dislodged from the DIMM socket. (See **Figure 4-8**)

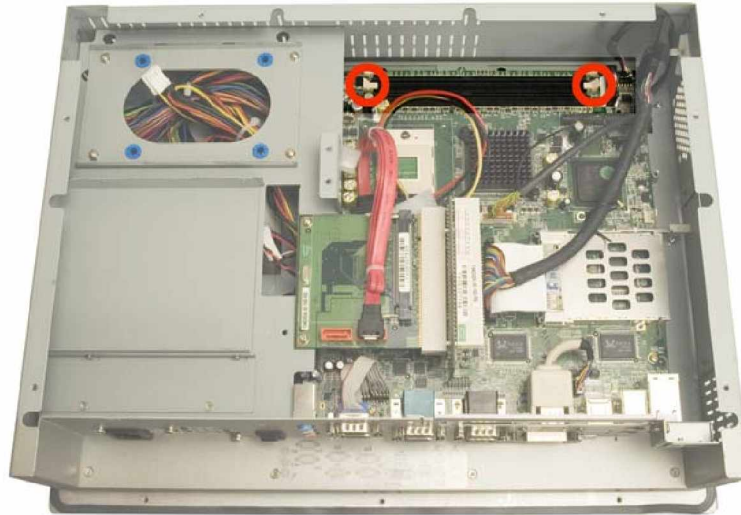

**Figure 4-8: DIMM Socket Clip Locations**

**Step 3:** Insert the new DIMM. Properly align the DIMM pins with the socket and the gently push the DIMM into the DIMM socket until the white side handles close.

## 4.5 PSU Module Replacement

If the PSU module has been damaged it must be replaced. To replace the PSU module, please follow the steps below.

**Step 1:** Remove the back cover. See **Section 4.3.1** above.

**Step 2:** Detach the elevated platform. See **Section 4.3.2** above.

**Step 3:** Remove the elevated platform from the 2901300.

**Step 4:** Disconnect the PSU power cable connectors from the motherboard (**Figure 4-9**)

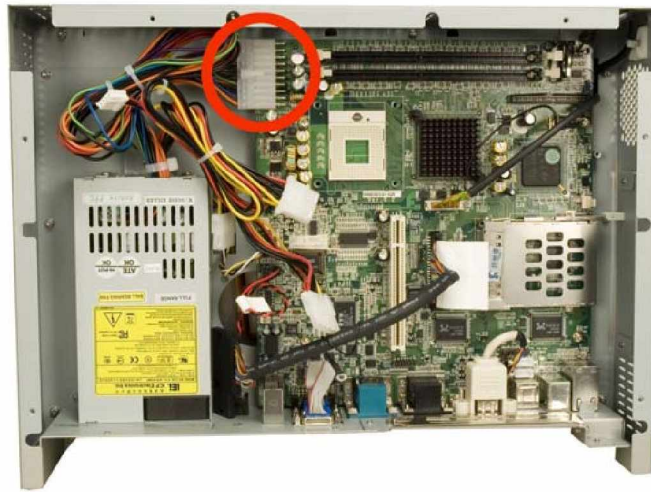

Figure 4-9: PSU Motherboard Connector

**Step 5:** The PSU module is secured to the 2901300 flat panel PC with four retention screws, one connects to the metal sheet at the back of the 15" TFT LCD screen (Figure 4-10) and the other three are inserted through the bottom panel and into the PSU module (Figure 4-11). Remove these four retention screws.



Figure 4-10: PSU Internal Retention Screws



**Figure 4-11: PSU External Retention Screws**

- Step 6:** Remove the PSU module from the 2901300 flat panel PC. The PSU module cables are connected together with ties. This is to help save space in the chassis. Disconnect the plastic tie.
- Step 7:** Bundle the cables of the new PSU module, and secure them with a plastic tie, in a similar way to the way the ties were bundled on the old PSU module.
- Step 8:** Reconnect the PSU module connector to the motherboard power connector (PW1). (Do this before inserting the PSU module.)
- Step 9:** Place the new PSU module into the 2901300 flat panel PC.
- Step 10:** Secure the new PSU module to the 2901300 flat panel PC by reinserting the retention screw into the metal plate behind the 15" TFT LCD screen and the three retention screws through the bottom panel of the 2901300 flat panel PC.
- Step 11:** Reattach the elevated platform and reinserting the elevated platform retention screws.
- Step 12:** Replace the back cover.

Appendix

A

# A Interface Connectors

---

## A.1 Peripheral Interface Connectors

The 2901300 flat panel PC motherboard, the 2804150 comes with a number of peripheral interface connectors and configuration jumpers listed in **Chapter 2**. The pinouts for these connectors are listed below:

### ↑ CN5: Front Panel Connector

PIN NO.	DESCRIPTION	PIN NO.	DESCRIPTION
1	SPEAKER_UP	2	LCD On/Off
3	SPEAKER_DOWN	4	5V Power
5	GND	6	PWRBTN
7	BKLT_UP	8	Standby Power
9	BKLT_DOWN	10	GND

### ↑ CN9: CD/DVD-ROM LED Indicator

PIN NO.	DESCRIPTION
1	+LED
2	-LED

### ↑ CN12 : System Panel Connectors

PIN NO.	DESCRIPTION	PIN NO.	DESCRIPTION
1-3	Power LED	2-8	Speaker
5-7	Power button	10-12	Reset
9-11	HDD LED		

### ↑ IDE1: Primary IDE Interface Connector

PIN NO.	DESCRIPTION	PIN NO.	DESCRIPTION
1	RESET#	2	GROUND
3	DATA 7	4	DATA 8
5	DATA 6	6	DATA 9
7	DATA 5	8	DATA 10
9	DATA 4	10	DATA 11
11	DATA 3	12	DATA 12

13	DATA 2	14	DATA 13
15	DATA 1	16	DATA 14
17	DATA 0	18	DATA 15
19	GROUND	20	N/C
21	IDE DRQ	22	GROUND
23	IOW#	24	GROUND
25	IOR#	26	GROUND
27	IDE CHRDY	28	GROUND
29	IDE DACK	30	GROUND-DEFAULT
31	INTERRUPT	32	N/C
33	SA1	34	N/C
35	SA0	36	SA2
37	HDC CS0#	38	HDC CS1#
39	HDD ACTIVE#	40	GROUND
41	VCC	42	VCC
43	GROUND	44	N/C

**IDE2: Secondary IDE Interface Connector**

PIN NO.	DESCRIPTION	PIN NO.	DESCRIPTION
1	RESET#	2	GROUND
3	DATA 7	4	DATA 8
5	DATA 6	6	DATA 9
7	DATA 5	8	DATA 10
9	DATA 4	10	DATA 11
11	DATA 3	12	DATA 12
13	DATA 2	14	DATA 13
15	DATA 1	16	DATA 14
17	DATA 0	18	DATA 15
19	GROUND	20	N/C
21	IDE DRQ	22	GROUND
23	IOW#	24	GROUND
25	IOR#	26	GROUND
27	IDE CHRDY	28	GROUND

29	IDE DACK	30	GROUND-DEFAULT
31	INTERRUPT	32	N/C
33	SA1	34	N/C
35	SA0	36	SA2
37	HDC CS0#	38	HDC CS1#
39	HDD ACTIVE#	40	GROUND
41	VCC	42	VCC
43	GROUND	44	N/C

**┆ CN7: Compact Flash Connector**

PIN NO.	DESCRIPTION	PIN NO.	DESCRIPTION
1	GROUND	26	VCC-IN CHECK1
2	DATA 3	27	DATA 11
3	DATA 4	28	DATA 12
4	DATA 5	29	DATA 13
5	DATA 6	30	DATA 14
6	DATA 7	31	DATA 15
7	HDC_CS0#	32	HDC_CS1
8	N/C	33	N/C
9	GROUND	34	IOR#
10	N/C	35	IOW#
11	N/C	36	VCC_COM
12	N/C	37	IRQ15
13	VCC_COM	38	VCC_COM
14	N/C	39	CSEL
15	N/C	40	N/C
16	N/C	41	HDD_RESET
17	N/C	42	IORDY
18	SA2	43	SDREQ
19	SA1	44	SDACK#
20	SA0	45	HDD_ACTIVE#
21	DATA 0	46	66DET
22	DATA 1	47	DATA 8
23	DATA 2	48	DATA 9

24	N/C	49	DATA 10
25	VCC-IN CHECK2	50	GROUND

**↑ CN1.A : CRT Connector**

PIN NO.	DESCRIPTION	PIN NO.	DESCRIPTION
1	RED	9	N/C
2	GREEN	10	GROUND
3	BLUE	11	N/C
4	N/C	12	DDCDAT
5	GROUND	13	HSYNC
6	GROUND	14	VSYNC
7	GROUND	15	DDCCLK
8	GROUND		

**↑ CN1.B : COM1 Connector(RS-232)**

PIN NO.	DESCRIPTION	PIN NO.	DESCRIPTION
1	DCD1	2	DSR1
3	RX1	4	RTS1
5	TX1	6	CTS1
7	DTR1	8	RI1
9	5V/12V	10	GND

**↑ J5 (Dual DB-9 CONNECTOR): COM2,COM3(RS-232)**

PIN NO.	DESCRIPTION	PIN NO.	DESCRIPTION
1	DCD3	2	DSR3
3	RX3	4	RTS3
5	TX3	6	CTS3
7	DTR3	8	RI3
9	5V/12V	10	GND

**↑ COM3 : COM3(RS-422/485) (14-pin Pin Header, Shared with J5-B connector)**

PIN NO.	DESCRIPTION	PIN NO.	DESCRIPTION
1	DCD3	2	DSR3
3	RX3	4	RTS3

5	TX3	6	CTS3
7	DTR3	8	RI3
9	GND	10	GND
11	TX3+	12	TX3-
13	RX3+	14	RX3-

**↑ COM4 : COM4(10-pin Pin Header)**

PIN NO.	DESCRIPTION	PIN NO.	DESCRIPTION
1	DCD3	2	DSR3
3	RX3	4	RTS3
5	TX3	6	CTS3
7	DTR3	8	RI3
9	5V	10	GND

**↑ COM5 and COM6 : COM5 & COM6(10-pin Pin Header)**

PIN NO.	DESCRIPTION	PIN NO.	DESCRIPTION
1	DCD3	2	DSR3
3	RX3	4	RTS3
5	TX3	6	CTS3
7	DTR3	8	RI3
9	GND	10	GND

**↑ KB\_MS1 : PS/2 Keyboard & Mouse Connector**

PIN NO.	DESCRIPTION	PIN NO.	DESCRIPTION
1	KB DATA	7	MS DATA
2	NC	8	NC
3	GND	9	GND
4	5V	10	5V
5	KB CLK	11	MS CLK
6	N/C	12	N/C

**↑ USB1: USB(0~1) Connector**

PIN NO.	DESCRIPTION	PIN NO.	DESCRIPTION
1	USBVCC0	2	USBVCC1

3	D0-	4	D1-
5	D0+	6	D1+
7	USBGND0	8	USBGND1

**↑ USB2: USB(2~3) Connector(2\*4 Pin header)**

PIN NO.	DESCRIPTION	PIN NO.	DESCRIPTION
1	USBVCC2	2	USBGND3
3	D2-	4	D3+
5	D2+	6	D3-
7	USBGND2	8	USBVCC3

**↑ USB3, USB4: USB(4~5) Connector(1\*5 Pin header)**

PIN NO.	DESCRIPTION	PIN NO.	DESCRIPTION
1	GND	2	USBVCC4
3	GND	4	D4+
5	D4-		

**↑ LAN1: DUAL RJ45 Connector**

PIN NO.	Description	PIN NO.	Description
A1	MDIOA0+	B1	MDIOB0+
A2	MDIOA0-	B2	MDIOB0-
A3	MDIOA1+	B3	MDIOB1+-
A4	MDIOA1-	B4	MDIOB1-
A5	MDIOA2+	B5	MDIOB2+-
A6	MDIOA2-	B6	MDIOB2-
A7	MDIOA3+	B7	MDIOB3+-
A8	MDIOA3-	B8	MDIOB3-
A9	N/C	B9	N/C
A10	N/C	B10	N/C
A11	LINK1000	B11	VCC
A12	LINK100	B12	LINK100
A13	ACT	B13	ACT
A14	LINK	B14	LINK
A15-17	GND	B15-17	GND

**↑ CN8: LCD LVDS Interface Connector**

PIN NO.	Description	PIN NO.	Description
1	GND	2	GND
3	LVDS_Y3+	4	LVDS_Y3-
5	LVDS_CLK+	6	LVDS_CLK-
7	LVDS_Y2+	8	LVDS_Y2-
9	LVDS_Y1+	10	LVDS_Y1-
11	LVDS_Y0+	12	LVDS_Y0-
13	GND	14	GND
15	LVDSB_Y3+	16	LVDSB_Y3-
17	LVDSBCLK+	18	LVDSBCLK-
19	LVDSB_Y2+	20	LVDSB_Y2-
21	LVDSB_Y1+	22	LVDSB_Y1-
23	LVDSB_Y0+	24	LVDSB_Y0-
25	GND	26	GND
27	VCC_LCD	28	VCC_LCD
29	VCC_LCD	30	VCC_LCD

**↑ CN3: Inverter Power Connector – JST/2.0mm G**

PIN NO.	DESCRIPTION	PIN NO.	DESCRIPTION
1	VCC12	2	VCC12
3	BKLT_EN	4	BKLT_ADJ
5	GND	6	GND

**↑ PW1: ATX Power Connector**

PIN NO.	DESCRIPTION	PIN NO.	DESCRIPTION
1	3.3V	11	3.3V
2	3.3V	12	-12V
3	GND	13	GND
4	5V	14	PSON
5	GND	15	GND
6	5V	16	GND
7	GND	17	GND
8	PWR OK	18	-5V

9	5VSB	19	5V
10	12V	20	5V

**↑ DIO1: 8 Bits GPIO Connector**

PIN NO.	DESCRIPTION	PIN NO.	DESCRIPTION
1	GND	2	VCC5
3	GPIO0	4	GPIO1
5	GPIO2	6	GPIO3
7	GPIO4	8	GPIO5
9	GPIO6	10	GPIO7

**↑ CPU\_FAN1, SYS\_FAN1, SYS\_FAN2: Fan Connectors**

PIN NO.	DESCRIPTION
1	Fan Speed Detect
2	+12V
3	GND

**↑ AUDIO1: Audio Connector (1\*3 pin header)**

PIN NO.	DESCRIPTION
1	Speaker Out R
2	GND
3	Speaker Out L

**↑ CN11: Audio Connector (Shared With AUDIO1)**

PIN NO.	DESCRIPTION	PIN NO.	DESCRIPTION
1	Speaker out R	2	GND
3	Speaker out L	4	GND
5	Line out R	6	Line out L
7	GND	8	GND
9	Line in R	10	Line in L
11	GND	12	GND
13	N/C	14	N/C

15	MIC1/CEN OUT	16	LFE OUT
----	--------------	----	---------

**↑ CN15: Power button connector**

PIN NO.	DESCRIPTION
1	PWR BTN
2	GND

**↑ CN16: LCD rotate**

PIN NO.	DESCRIPTION
1	LCD Rotate
2	GND

**↑ IR1: IR Interface**

PIN NO.	DESCRIPTION	PIN NO.	DESCRIPTION
1	VCC5	2	N/C
3	IRRX	4	GND
5	IRTX	6	

Any advice or comments about our products and service, or anything we can help you with please don't hesitate to contact with us. We will do our best to support you for your products, projects and business.

**Global American Inc.**

Address: 17 Hampshire Drive  
Hudson, NH 03051

TEL: Toll Free (U.S. Only) 800-833-8999  
(603)886-3900

FAX: (603)886-4545

Website: <http://www.globalamericaninc.com>

E-Mail: [salesinfo@globalamericaninc.com](mailto:salesinfo@globalamericaninc.com)

