



User's Manual

2901270

Version 1.0

April 2007

Copyrights

This manual is copyrighted and all rights are reserved. It does not allow any non authorization in copied, photocopied, translated or reproduced to any electronic or machine readable form in whole or in part without prior written consent from the manufacturer.

In general, the manufacturer will not be liable for any direct, indirect, special, incidental or consequential damages arising from the use of inability to use the product or documentation, even if advised of the possibility of such damages. The manufacturer keeps the rights in the subject to change the contents of this manual without prior notices in order to improve the function design, performance, quality and reliability. The author assumes no responsibility for any errors or omissions, which may appear in this manual, nor does it make a commitment to update the information contained herein.

Trademarks

Intel is a registered trademark of Intel Corporation.

Award is a registered trademark of Award Software, Inc.

All other trademarks, products and or product's name mentioned herein are mentioned for identification purposes only, and may be trademarks and/or registered trademarks of their respective companies or owners.

Packing List



NOTE:

If any of the components listed in the checklist below are missing, please do not proceed with the installation. Contact Global American, Inc. (GAI) or contact a GAI sales representative directly. To contact a GAI sales representative, please send an email to salesinfo@globalamericaninc.com.

The items listed below should all be included in the 2901270 package.

- „ 1 x CD-ROM Installation Kit
- „ 1 x Screw Kit
- „ 2 x SATA HDD Cable
- „ 1 x FFC Cable
- „ 1 x Jumper Pack
- „ 1 x RS-232 Cable
- „ 1 x Power Cable
- „ 1 x PS/2 Cable
- „ 1 x CPU Cooler
- „ 1 x User Manual & Driver CD-ROM
- „ 1 x Panel Mounting Kit
- „ 1 x Wall Mounting Kit
- „ 1 x Touch Screen Driver CD (Touch Screen Model only)
- „ 1 x Touch Pen (Touch Screen Model only)

Images of the above items are shown in **Chapter 3**.

Precautions

SAFETY PRECAUTIONS

1. Prior to installing, moving, and modifying the panel PC, make sure that the unit's power is turned off and the power cord is disconnected.
2. Do not apply voltage levels that exceed the specified voltage range. Doing so may cause fire or an electrical shock.
3. Electric shock can occur if the panel is opened. Do not drop or insert any objects into the ventilation openings of the panel PC.
4. Only qualified engineers from certified system integrators or VARs are allowed to make necessary functional modifications to the panel PC, e.g., adding a touch screen. GAI offers the customization service on a pre-order basis.
5. If considerable amount of dust, water, or fluids entered the panel PC, turn off the power supply immediately, unplug the power cord, and contact the vendor.
6. Explosions may occur with installations in environments where flammable gases are present.
7. Fault-tolerant and failsafe designs should be implemented with the use of the series models on transportation vehicles, ships, safety/security devices, or medical devices not related to life-support functionalities. Users/integrators should take the responsibility for implementations with adequate levels of reliability and safety.
8. Preventive designs should be implemented so as to avoid the communications faults between the panel PC and the PC/workstation/terminals that control it.

HANDLING PRECAUTIONS

1. Do not drop the panel PC against a hard surface. Doing so may damage the display.
2. Do not strike or exert excessive force onto the touch panel.
3. Touching the touch panel using a sharp object may damage the LCD panel.
4. Avoid environments exposed to direct sunlight, dust, or chemical vapors.
5. The panel PC is actively cooled. In no circumstances should the panel PC

operate with the openings obstructed by foreign objects. However, the ambient temperature of the installation site should be observed and controlled to avoid overheating the panel PC.

6. Condensation might form inside the panel PC chassis if exposed to sudden changes in temperature.
7. Carefully route the power cord so that people cannot step on it. Do not place anything over the power cord.
8. If the equipment should be left unused for an extended period of time, disconnect it from the power source to avoid damage by transient over-voltage.
9. If any of the following situations arises, get the equipment checked by service personnel:
 - The power cord or plug is damaged.
 - Liquid has penetrated into the equipment.
 - The equipment has been exposed to moisture.
 - The equipment does not work properly, or the user cannot get it to work according to the user manual.
 - The equipment has been dropped and damaged.
 - The equipment shows obvious signs of breakage.



WARNING!

Any changes or modifications made to the equipment that are not expressly approved by the relevant standards could void the authority to operate the equipment.

MAINTENANCE AND CLEANING

Note the following precautions before beginning to clean the Panel PC.

When cleaning any single part or component of the computer, please read and understand the details below fully.

- „ Except for the properly installed front LCD panel, never spray or squirt liquids directly onto any computer component. To clean the device, please rub it with

2901270 Flat Panel PC

a piece of dry and soft cloth or a slightly moistened cloth with the exterior casing.

- „ The interior of the Panel PC does not require cleaning. Keep fluids away from the Panel PC and the interior of it.
- „ Be cautious of the tiny removable components when using a vacuum cleaner to absorb the dirt on the floor.
- „ Turn the system off before cleaning up the Panel PC.
- „ Never drop any tiny objects through the openings of the Panel PC or get circuit board damp or wet.
- „ Be cautious of all kinds of cleaning solvents or chemicals when using it for the sake of cleaning. Some individuals may be allergic to the ingredients.
- „ Avoid any food, drink or cigarette around the Panel PC.

CLEANING TOOLS

Although many companies have created products to help improve the process of cleaning the computer and peripherals, users can also use household items to clean their computers and peripherals. Below is a list of items to use while cleaning the computer or computer peripherals.

Please keep in mind that some components in the computer may only be cleaned using a product designed for cleaning that component, if this is the case it will be mentioned in the cleaning tips.

- „ **Cloth** - A piece of cloth is the best tool to use when rubbing up a component. Although paper towels or tissues can be used on most hardware as well, it is recommended to rub it with a piece of cloth.
- „ **Water or rubbing alcohol** – Moisten a piece of cloth a bit with some water or rubbing alcohol and rub it on the computer.
- „ Unknown solvents may be harmful to the plastics parts.
- „ **Vacuum cleaner** - Absorb the dust, dirt, hair, cigarette particles, and other particles out of a computer can be one of the best methods of cleaning a computer. Over time these items can restrict the airflow in a computer and cause circuitry to corrode.

2901270 Flat Panel PC

- „ **Cotton swabs** - Cotton swabs moistened with rubbing alcohol or water are excellent tools for wiping hard to reach areas in the keyboard, mouse, and other locations.
- „ **Foam swabs** - Whenever possible it is better to use lint free swabs such as foam swabs.

ESD PRECAUTIONS

Observe all conventional anti-ESD methods while handling the components contained within the LCD should the need arise for adding a functionality. The use of a grounded wrist strap and an anti-static work pad is recommended. Avoid dust and debris or other static-accumulating materials in the work area.

Table of Contents

1	INTRODUCTION.....	1
1.1	OVERVIEW	2
1.1.1	<i>2901270 Model Variation.....</i>	2
1.1.2	<i>Applications</i>	3
1.1.3	<i>Features</i>	3
1.2	EXTERNAL OVERVIEW	3
1.2.1	<i>General Description.....</i>	3
1.2.2	<i>Front Panel</i>	4
1.2.3	<i>Rear Panel</i>	4
1.2.4	<i>Bottom Panel.....</i>	5
1.2.5	<i>Right Panel.....</i>	6
1.2.6	<i>Frame.....</i>	6
1.3	2901270 INTERNAL OVERVIEW	7
1.4	SPECIFICATIONS	7
1.4.1	<i>Preinstalled Hardware Components.....</i>	7
1.4.2	<i>System Specifications.....</i>	8
1.4.3	<i>Motherboard Specifications.....</i>	10
1.4.4	<i>Flat Panel Screen Specifications</i>	11
1.4.5	<i>Power Supply Specifications.....</i>	12
1.4.5.1	<i>180W AC Input Power Supply.....</i>	12
1.4.5.2	<i>200W DC Input Power Supply</i>	14
1.5	2901270 DIMENSIONS	16
2	3302160 MOTHERBOARD	17
2.1	INTRODUCTION	18
2.2	CPU SUPPORT.....	18
2.3	ONBOARD CHIPSETS	18
2.3.1	<i>Northbridge and Southbridge Chipsets</i>	18
2.3.2	<i>SiS661CX Northbridge Chipset</i>	18
2.3.3	<i>SiS964 Southbridge Chipset.....</i>	19
2.4	GRAPHICS SUPPORT	20

2.5 PERIPHERAL DEVICE INTERFACES, CONNECTORS, AND SLOTS 20

 2.5.1 OEM Options 21

 2.5.2 Internal Slots 21

 2.5.3 Internal Peripheral Device Connectors 21

 2.5.4 External Peripheral Device Connectors 22

3 INSTALLATION AND CONFIGURATION 23

 3.1 INSTALLATION PRECAUTIONS 24

 3.2 PREINSTALLED COMPONENTS 24

 3.3 INSTALLATION AND CONFIGURATION STEPS 25

 3.4 UNPACKING 25

 3.4.1 Packing List 26

 3.5 JUMPER SETTINGS 28

 3.5.1 Open the Back Cover 30

 3.5.1.1 2901270 Back Cover Removal 30

 3.5.2 CPU FSB Settings Jumper 30

 3.5.3 CPU Frequency Setting Jumper 31

 3.5.4 CF Card Setup 31

 3.5.5 LCD Voltage Setup Jumper 31

 3.5.6 COM2 Setup Jumper 32

 3.6 CPU AND CPU COOLER INSTALLATION 32

 3.6.1 CPU Installation 32

 3.6.2 Cooling Kit Installation 34

 3.7 SO-DIMM MODULE INSTALLATION 35

 3.8 2.5” HDD INSTALLATION 37

 3.9 CD DRIVE INSTALLATION 39

 3.10 3.5” HDD INSTALLATION 42

 3.10.1 3.5” HDD Installation 42

 3.10.2 Removable 3.5” HDD Installation 43

 3.11 FDD INSTALLATION 45

 3.12 PCI CARD INSTALLATION 47

 3.13 MOUNTING THE SYSTEM 49

 3.13.1 Wall Mounting 49

 3.13.2 Panel Mounting 52

 3.13.3 Arm Mounting 54

2901270 Flat Panel PC

3.13.4 Cabinet and Rack Installation	55
3.14 REAR PANEL CONNECTORS	57
3.14.1 LCD Panel Connection	57
3.14.2 Ethernet Connection	58
3.14.3 Serial Ports	58
3.14.4 Audio Interface.....	58
3.14.5 USB Connections	59
3.14.6 Keyboard and Mouse Connection.....	59
3.14.7 Parallel Port Connector (LPT1).....	59
3.15 SYSTEM MAINTENANCE	59
A INTERFACE CONNECTORS	60
A.1 PERIPHERAL INTERFACE CONNECTORS	61

List of Figures

Figure 1-1: Front View.....	4
Figure 1-2: VESA Mounting Screw Holes	4
Figure 1-3: Bottom View	5
Figure 1-4: Right View.....	6
Figure 1-5: Panel Mount Retention Screw Holes	6
Figure 1-6: Unique Rear Hinge Design.....	7
Figure 1-7: 180W AC Input Power Supply (3107750)	12
Figure 1-8: 200W DC Input Power Supply (3102170).....	14
Figure 1-9: 2901270 Dimensions (units in mm).....	16
Figure 3-1: Jumper Locations.....	28
Figure 3-2: Motherboard Jumper Locations.....	29
Figure 3-3: 2901270 Back Cover Retention Screws.....	30
Figure 3-4: Make sure the CPU socket retention screw is unlocked	33
Figure 3-5: Lock the CPU Socket Retention Screw	34
Figure 3-6: Securing the Cooling Kit.....	35
Figure 3-7: Connect the cooling fan cable	35
Figure 3-8: The Elevated Platform Retention Screws.....	36
Figure 3-9: 2901270 SO-DIMM Socket Location	36
Figure 3-10: SO-DIMM Module Installation	37
Figure 3-11: 2.5” HDD Bracket Retention Screws.....	38
Figure 3-12: 2.5” HDD Retention Screws	38
Figure 3-13: CD Drive Retention Screws	39
Figure 3-14: CD Drive Blank Plate Assembly	40
Figure 3-15: CD Drive with Bracket	40
Figure 3-16: CD Drive Adapter Installation.....	41
Figure 3-17: CD Drive Retention Screw (Rear Panel)	41
Figure 3-18: 3.5” HDD Bracket Retention Screws.....	42
Figure 3-19: 3.5” HDD Retention Screws.....	43

Figure 3-20: 3.5" HDD Bay Retention Screws43

Figure 3-21: Removable 3.5" HDD Installation44

Figure 3-22: 3.5" Removable HDD Retention Screws.....45

Figure 3-23: Release Locking Mechanism.....45

Figure 3-24: Serial Port Connector Retention Screws46

Figure 3-25: FDD Bracket Retention Screws46

Figure 3-26: FDD Retention Screws (Bottom Panel)47

Figure 3-27: FDD Retention Screw (Rear Panel)47

Figure 3-28: USB Port Bracket Retention Screws48

Figure 3-29: PCI Card Installation.....48

Figure 3-30: Wall-mounting Bracket.....50

Figure 3-31: Mount the Chassis.....51

Figure 3-32: Secure the Chassis.....52

Figure 3-33: Suggested Panel Cut Out Size for 290127053

Figure 3-34: Tighten the Panel Mounting Clamp Screws.....54

Figure 3-35: Arm Mounting Retention Screw Holes55

Figure 3-36: Secure the Rack/Cabinet Bracket56

Figure 3-37: Install into a Rack/Cabinet57

Figure 3-38: Audio Interface.....58

List of Tables

Table 1-1: 2901270 Model Variation	2
Table 1-2: System Specifications	9
Table 1-3: Motherboard Specifications	10
Table 1-4: TFT LCD Monitor Specifications.....	11
Table 1-5: 180W AC Input Power Supply (3107750) Specifications	13
Table 1-6: 200W DC Input Power Supply (3102170) Specifications.....	15
Table 3-1: FSB Selection Jumper Settings	30
Table 3-2: CPU Frequency Jumper Settings	31
Table 3-3: CF Card Setup Jumper Settings	31
Table 3-4: JP1 Jumper Settings	32
Table 3-5: CON1 Jumper Settings	32

Introduction

1.1 Overview

The 2901270 flat panel PC is a flexible, multi-functional flat panel PC that can be applied in diverse operational environments and implemented in multi-faceted applications. The 2901270 comes fully kitted with a high-performance motherboard and a host of other peripheral interface connectors. The 2901270 is designed for ease of use and easy installation.

1.1.1 2901270 Model Variation

Four GAI 2901270 models are available. The models are listed in **Table 1-1**.

2901270	CPU	Socket	Touch Screen	Power Supply
2901270A	Pentium® M / Celeron® M FSB 400MHz	Socket 479	No	180W ATX AC-input
2901270B	Pentium® M / Celeron® M FSB 400MHz	Socket 479	Yes	180W ATX AC-input
2901270C	Pentium® M / Celeron® M FSB 400MHz	Socket 479	No	200W ATX DC-input
2901270D	Pentium® M / Celeron® M FSB 400MHz	Socket 479	Yes	200W ATX DC-input

Table 1-1: 2901270 Model Variation

2901270 Flat Panel PC

1.1.2 Applications

The flat panel PC is designed for rigorous industrial environments where it may be exposed to both heat and moisture. Its durability and strength also makes it an ideal choice for public access computers. Some possible applications include:

- „ Automated manufacturing processes
- „ Public information gathering point

1.1.3 Features

Some of the standard features of the 2901270 flat panel PC include:

- „ Intel® Pentium® M / Celeron® M FSB 533MHz CPU up to 2.1GHz
- „ DDR 400/333 SO-DIMM socket supports up to 1GB memory module
- „ Aluminum die-casting IP 65
- „ Unique rear hinge design decreases the maintenance, cost and time
- „ Removable 3.5” HDD module
- „ Serial ATA interface support
- „ Gigabit Ethernet support
- „ Simplified installation process
- „ RoHS compliance

1.2 External Overview

1.2.1 General Description

The flat panel PC is comprised of a screen, rear panel, top panel, bottom panel and two side panels (left and right). An aluminum frame surrounds the front screen. The rear panel provides screw holes for a wall-mounting bracket or arm-mounting interface. The bottom panel provides access to external interface connectors that include LAN, USB 2.0, audio, VGA, serial port connectors and a CF card slot. Two USB ports and two serial ports are removable and can be replaced by a floppy disk drive or a PCI card.

1.2.2 Front Panel

The front side of the 2901270 is a flat panel TFT LCD screen surrounded by an aluminum frame.

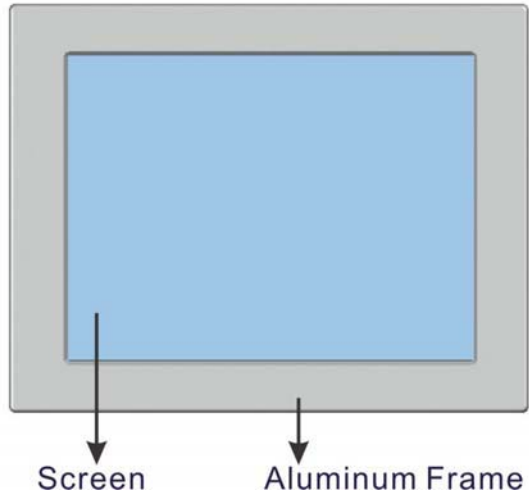

Figure 1-1: Front View

1.2.3 Rear Panel

The rear panel has two vents and four VESA screw holes that support a wall-mounting bracket. **Figure 1-2** shows the VESA screw holes of the 2901270.

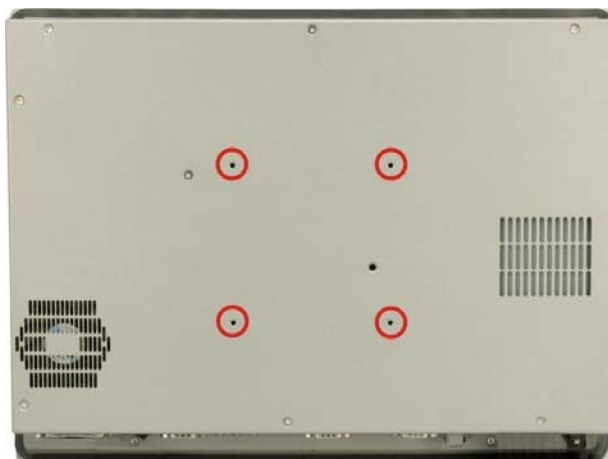

Figure 1-2: VESA Mounting Screw Holes

2901270 Flat Panel PC

1.2.4 Bottom Panel

All peripheral device connectors are located on the bottom panel of the flat panel PC. The following is a list of the bottom panel peripheral device connectors used on the 2901270 flat panel PC. **Figure 1-3** shows the location of these connectors.

- „ 3 x Audio jacks (Line-in, Line-out and MIC-in)
- „ 1 x CompactFlash® slot
- „ 1 x Parallel connector
- „ 1 x Power switch
- „ 1 x PS/2 keyboard/mouse connector
- „ 1 x RJ-45 GbE connector
- „ 1 x RS-232/422/485 port
- „ 1 x RS-232 port
- „ 4 x USB 2.0 connectors
- „ 1 x VGA connector
- „ 2 x Optional RS-232 ports
- „ 2 x Optional USB 2.0 connectors
- „ 1 x Floppy disk drive bay
- „ 1 x PCI card slot

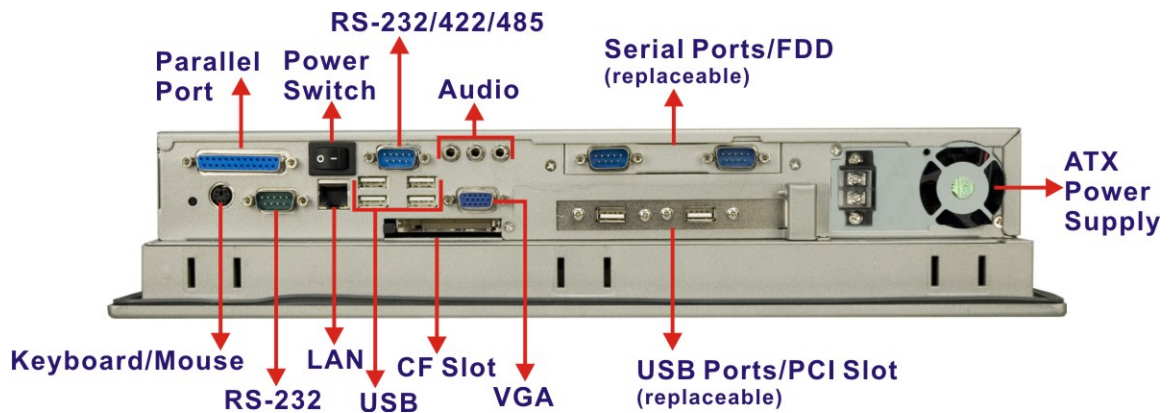

Figure 1-3: Bottom View

1.2.5 Right Panel

The right panel of the 2901270 has vents and provides access to the slim type CD drive bay and 3.5" HDD bay (Figure 1-4).



Figure 1-4: Right View

1.2.6 Frame

An aluminum frame surrounds the TFT LCD screen. The aluminum frame of the 2901270 has small screw holes that are used when the flat panel PC is mounted into a rack or cabinet. These screws are circled in Figure 1-5.

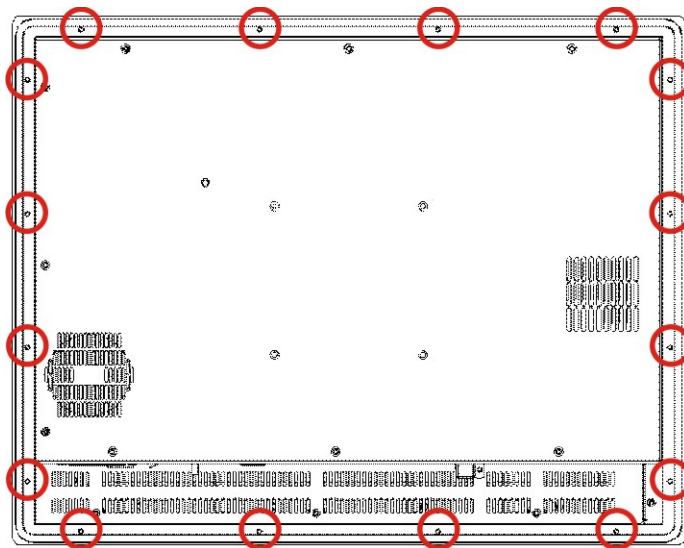

Figure 1-5: Panel Mount Retention Screw Holes

2901270 Flat Panel PC

1.3 2901270 Internal Overview

The 2901270 internal components are configured in a three level format. After opening the back cover, the user can access an elevated platform installed with a motherboard and a PSU module. The elevated platform also supports a CD drive, a 3.5" HDD and two 2.5" HDDs. The platform can be opened by removing three retention screws. A 17" TFT LCD screen and an inverter board are installed in the level below the elevated platform.

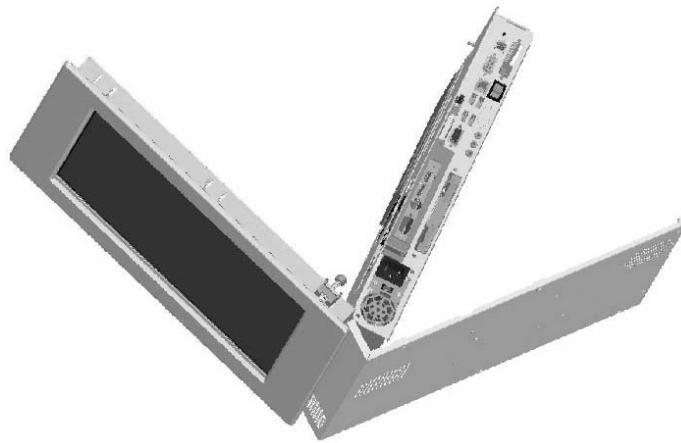

Figure 1-6: Unique Rear Hinge Design

1.4 Specifications

1.4.1 Preinstalled Hardware Components

The flat panel PC comes with the following components:

- „ 1 x Motherboard (preinstalled)
- „ 1 x TFT LCD screen (preinstalled)
- „ 1 x Power supply (preinstalled)

The technical specifications for these components and the system are shown in the sections below.

1.4.2 System Specifications

The technical specifications for the 2901270 system are listed in **Table 1-2**.

SPECIFICATION	2901270
Front Panel	Aluminum Front Panel
Chassis	Heavy-duty Steel
LCD Panel	17" TFT LCD
Resolution	1280 x 1024 (SXGA)
Brightness	300 cd/m²
Viewing Angle	140/130 (H-V)
Backlight MTBF	50,000 hrs
Contrast Ratio	500:1
Touch Screen	Optional Resistive type touch screen with RS-232 interface
Memory	1 x DDR 400/333MHz SO-DIMM socket up to 1GB
Display	Support Dual Display
Drive Bay	1 x 3.5" SATA/IDE removable HDD bay 1 x Slim Type CD-ROM bay 1 x Slim Type FDD bay
SSD	1 x CF Type II slot
Expansion Slot	1 x PCI slot

2901270 Flat Panel PC

SPECIFICATION	2901270
I/O	<p>1 x RS-232/422/485 port</p> <p>1 x RS-232 port</p> <p>4 x USB 2.0 ports</p> <p>1 x PS/2 keyboard/mouse connector</p> <p>1 x VGA connector</p> <p>1 x LPT connector</p> <p>1 x GbE connector</p> <p>3 x Audio jacks</p> <p>2 x Optional RS-232 ports</p> <p>2 x Optional USB 2.0 ports</p>
Power Supply	<p>180W AC-input ATX power:</p> <p>- Input: 90 ~ 240VAC @ 50/60Hz</p> <p>- Output (max.): 3.3V @ 16.8A, 5V @ 12A, 12 @ 10A, 12 @ 0.8A</p>
Mounting Feature	Panel, Arm, Wall, or Rack
Color	Silver (PANTONE PMS-8001)
Operating Temp.	0 ~ 50°C
Storage Temperature	-20°C ~ 60°C
Relative Humidity	5 ~ 95% @ 60°C, non-condensing
Vibration	<p>5 - 17Hz, 0.1" double amplitude displacement.</p> <p>17 - 640Hz, 1.5G acceleration, peak to peak.</p>
Shock	10G Acceleration, peak to peak (11ms)
Dimension (mm)	452 x 356 x 80
Net/Gross Weight	8/12 kg

Table 1-2: System Specifications

1.4.3 Motherboard Specifications

The 2901270 flat panel PC comes with an 3302160 motherboard. The technical specifications of the motherboard are listed in **Table 1-3**.

SPECIFICATION	DETAIL
CPU's Supported	Intel® Pentium® M / Intel® Celeron® M
Chipsets	Northbridge: SIS 661CX Southbridge: SIS 964
I/O Controller	SIS 964
Graphics Support	SiS Mirage™ Graphic Engine
Memory	One DDR SO-DIMM memory module (Max. 1GB)
PCI Bus Interface	33MHz, Revision 2.3
Serial ATA (SATA)	Two SATA channels with 150MB/s transfer rates
HDD Interface	Two IDE channels supports four Ultra ATA 133/100/66/33 devices
Floppy Disk Drive (FDD)	Supports FDD
Real Time Clock	256-byte battery backed CMOS RAM
Hardware Monitoring	Cooling fans, temperature and system voltages
Ethernet	Gigabit Ethernet (GbE)
BIOS	AMI flash BIOS
Physical Dimensions	185mm x 123mm (width x length)
Operating Temperature	Minimum: 0°C (32°F) Maximum: 60°C (140°F)
Audio Interfaces	One Audio Codec '97 (AC'97) version 2.3 connector

Table 1-3: Motherboard Specifications

2901270 Flat Panel PC

1.4.4 Flat Panel Screen Specifications

The 2901270 comes with a 17" TFT LCD monitor at the front of the flat panel PC. The specifications for the LCD monitors are shown in **Table 1-4** below.

Size	17"
Model	M170EG01 VD
Resolution (pixel)	SXGA (1280 x 1024)
Aspect Ratio	5:04
Active Area (mm)	337.9 x 270.3
Pixel Pitch (mm)	0.264
Mode	TN
Number of Colors	16.2M
Color Saturation (%)	72
View Angle (H/V)	160 / 160
Brightness (cd/m²)	300
Contrast Ratio	800:01:00
Response Time (ms) (at 25°C)	5 (on/off)
Power Consumption (W)	25.8
Interface	2ch LVDS
Supply Voltage (V)	5
Backlight	4 CCFL
Outline Dimensions (mm)	358.5 x 296.5 x 15.0
Weight (g)	1900

Table 1-4: TFT LCD Monitor Specifications

1.4.5 Power Supply Specifications

1.4.5.1 180W AC Input Power Supply

Some of the 2901270 models are shipped with a 180W AC input 1U ATX power supply (3107750). (See **Figure 1-7**)



Figure 1-7: 180W AC Input Power Supply (3107750)

2901270 Flat Panel PC

The specifications for the power supply are listed in **Table 1-5**:

Input	Voltage	90 ~ 265VAC Full Range		
	Frequency	47 ~ 63Hz		
	Input Current	4A(RMS)@115VAC 2A(RMS)@230VAC		
	Inrush Current	50A Max for 115VAC 80A Max for 230VAC		
Output	Voltage	Min. load	Max. load	Ripple & Noise
	+3.3V	0.3A	16.8A	50mV
	+5V	0.3A	12A	50mV
	+12V	1.5A	10A	120mV
	-12V	0A	0.8A	120mV
	+5Vsb	0A	2A	50mV
	+3.3V & +5V ≤ 61W +3.3V & +5V & +12V ≤ 160W			
General	Watt	180W		
	PFC	Active		
	Hold-up time	17ms minimum		
	Efficiency	68%		
	MTBF	100,000hrs		
	Temperature	0 ~ 50°C (Operating) -20 ~ 80°C (Storage)		
	Dimension	150 x 81.5 x 40.5 mm		

Table 1-5: 180W AC Input Power Supply (3107750) Specifications

1.4.5.2 200W DC Input Power Supply

Some of the 2901270 models are shipped with a 200W 24V DC input 1U ATX power supply (3102170). (See **Figure 1-8**)



Figure 1-8: 200W DC Input Power Supply (3102170)

2901270 Flat Panel PC

The specifications for the power supply are listed in **Table 1-6**:

Input	Voltage	-18 ~ -36VDC Input																										
	Input Current	15A(RMS) @ -24VDC																										
	Inrush Current	100A Max for -24VDC																										
Output	<table border="1"> <thead> <tr> <th>Voltage</th> <th>Min. load</th> <th>Max. load</th> <th>Ripple & Noise</th> </tr> </thead> <tbody> <tr> <td>+5V</td> <td>1A</td> <td>12A</td> <td>50mV P-P</td> </tr> <tr> <td>+12V</td> <td>0.5A</td> <td>15.4A</td> <td>120mV P-P</td> </tr> <tr> <td>-12V</td> <td>0A</td> <td>0.5A</td> <td>120mV P-P</td> </tr> <tr> <td>+3.3V</td> <td>0A</td> <td>12A</td> <td>50mV P-P</td> </tr> <tr> <td>+5Vsb</td> <td>0A</td> <td>2A</td> <td>50mV P-P</td> </tr> </tbody> </table>				Voltage	Min. load	Max. load	Ripple & Noise	+5V	1A	12A	50mV P-P	+12V	0.5A	15.4A	120mV P-P	-12V	0A	0.5A	120mV P-P	+3.3V	0A	12A	50mV P-P	+5Vsb	0A	2A	50mV P-P
	Voltage	Min. load	Max. load	Ripple & Noise																								
	+5V	1A	12A	50mV P-P																								
	+12V	0.5A	15.4A	120mV P-P																								
	-12V	0A	0.5A	120mV P-P																								
	+3.3V	0A	12A	50mV P-P																								
+5Vsb	0A	2A	50mV P-P																									
* +3.3V&+5V total current not exceed 80W																												
Over-voltage protection	+5V output 5.7V ~ 6.5V +12V output 13.1V ~ 14.5V +3.3V output 3.7V ~ 4.1V																											
Over Circuit protection	+5V output 13.2A ~ 18A +12V output 17.6A ~ 24A +3.3V output 13.2A ~ 18A																											
Output rise time	20 ms Max.																											
Efficiency	78% Min.																											
General Specification	MTBF	100,000 hours on max load at +25°C																										
	Temperature	Operating : 0 ~ 50°C Storage : -20 ~ 80°C																										
	Outline connector	20+4PIN ATX x1, 4PIN 12V CPU x1, HDD/CDROM x2, FDD x1, SATA x1																										

Table 1-6: 200W DC Input Power Supply (3102170) Specifications

1.5 2901270 Dimensions

The dimensions of the 2901270 flat panel PC are shown in

Figure 1-9 below.

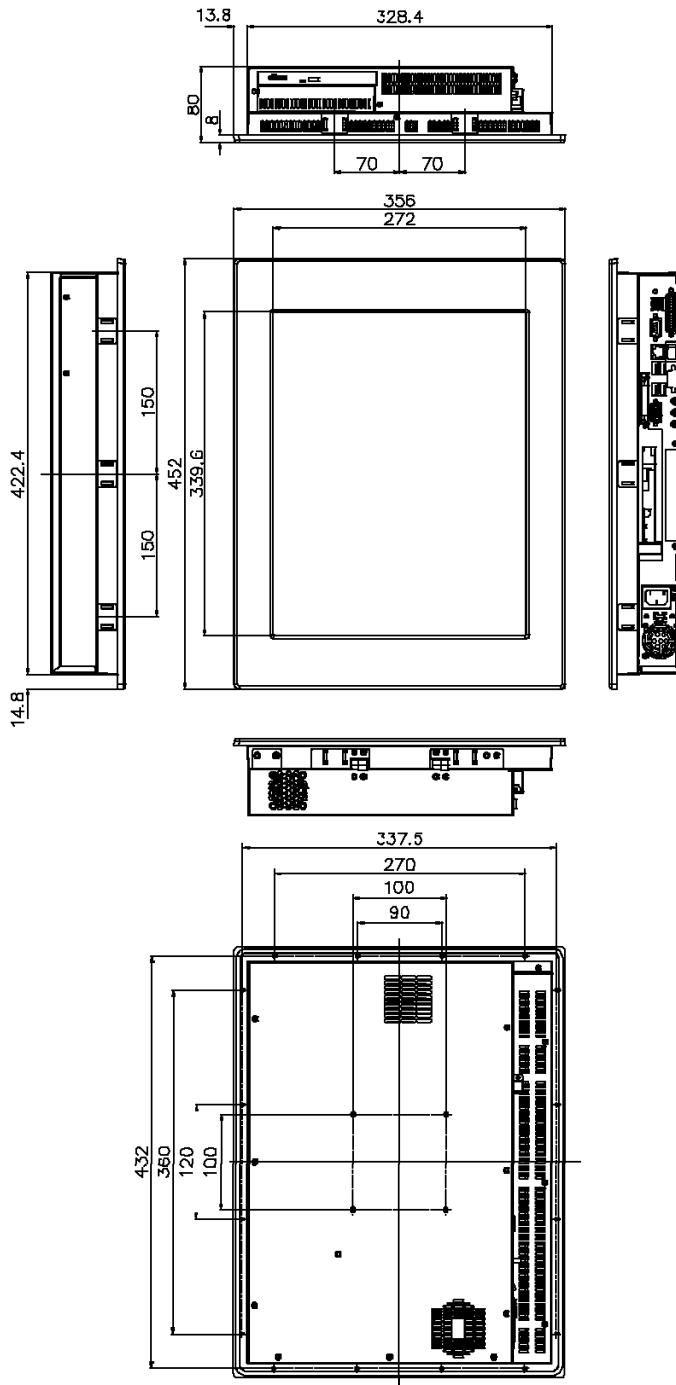

Figure 1-9: 2901270 Dimensions (units in mm)

3302160

Motherboard

2.1 Introduction

The 2901270 contains an 3302160 motherboard. The motherboard is the heart of any computer and is responsible for transmitting, receiving and processing data as well as driving the different onboard devices. This chapter gives a brief introduction to the 3302160 motherboard. For more complete details on the connectors and the different implementations of the 3302160, please refer to the 3302160 user guide.

2.2 CPU Support

The 3302160 installed in the flat panel PC supports socket 479, Intel® Pentium® M / Celeron® M FSB 400 MHz CPU.

2.3 Onboard Chipsets

2.3.1 Northbridge and Southbridge Chipsets

The following chipsets are preinstalled on the board:

- „ **Northbridge:** SiS661CX
- „ **Southbridge:** SiS964

The following two sections (**Section 2.3.2** and **Section 2.3.3**) list some of the features of the SiS661CX and the SiS964 chipsets. For more information on these two chipsets please refer to the Intel® website.

2.3.2 SiS661CX Northbridge Chipset

The SiS661CX northbridge chipset comes with the following features:

- „ Host Interface
 - 12 Outstanding Transactions support
 - Quasi-Synchronous/Asynchronous Host/DRAM Timing support
 - Supports 2M/4M/8M/16M TSEG SMRAM
 - Supports Dynamic Bus Inversion.
- „ DRAM Controller
 - DDR400/DDR333/DDR266 supported

2901270 Flat Panel PC

- Up to two un-buffered DIMMs DDR400 supported
- Up to 1GB per DIMM with 512Mb tech.
- Dynamic Clock Enable (CKE) control placing the Memory into Suspend to DRAM state.
- „ SiS MuTIOL® 1G Delivering 1GB/s Bandwidth
 - Proprietary Interconnect between Northbridge and Southbridge
 - Bi-Directional 16 bit Data Bus at 533MHz Operating Frequency

2.3.3 SiS964 Southbridge Chipset

The SiS964 southbridge chipset comes with the following features:

- „ SiS MuTIOL® 1G Delivering 1GB/s Bandwidth
 - Proprietary Interconnect between SiS north bridge and SiS964 southbridge
 - Bi-Directional 16 bit Data Bus at 533MHz Operating Frequency
- „ Integrated Serial Host Controller
 - Provides 2 independent ports for SATA, compliant with Serial ATA 1.0 specification with transfer rate 1.5Gb/s
 - Supports RAID 0, 1 and JBOD
- „ USB 2.0/1.1 Host Controller
 - One EHCI USB 2.0 controller
 - Supports Total 8 USB 2.0 ports
 - Supports USB 2.0 High-Speed Device @480 Mb/s transfer rates
- „ Fast Ethernet Controller with MII Interface
 - Supports 10/100Mb Fast Ethernet with External PHY
- „ Supports six channels AC'97 Rev.2.3 Audio and V.90 Software Modem
- „ Advanced Power Management: ACPI 1.0b and APM 1.2 Compliant
- „ Dual IDE channels with ATA 133/100
- „ Supports up to six PCI Masters
- „ LPC 1.1 Interface
- „ Integrated Keyboard/PS2 Mouse Controller

2.4 Graphics Support

The graphics features listed below are all integrated on the SiS661CX northbridge chipset.

- „ AGP 3.5 and AGP 2.0 Compliant
 - AGP 8X/4X mode support
 - Fast Write support
 - 1.5V interface support only
- „ DX9 S/W Compliant
- „ High performance 256Bit 3D/128Bit 2D Graphic Engine
 - 2 pixel rendering pipelines and 4 texture units per cycle (2P4T)
 - Up to 200 MHz ECLK
- „ SiS Ultra-AGP™ Technology w/ up to 3.2GB/s Data Transfer Rate
 - Successor of Ultra-AGP™ Technology and doubles the bandwidth up to 3.2GB/s with DDR400
 - AGP 8X equivalent bandwidth for 3D/2D/Video
- Advanced Hardware Acceleration for DVD playback
- Dual 12-bit DDR Digital Interface for Digital LCD/TV-OUT support
 - NTSC/PAL TV-OUT
 - LCD Monitor
 - Dual view function support for LCD-TV,LCD-CRT or CRT-TV
- „ Built-in high performance 333MHz RAMDAC
- „ Graphics support mode
 - CRT highest resolution mode: 2048x1536x32@75NI
 - LCD highest resolution mode: 1600x1200x32@ 60NI
 - TV highest resolution mode: 1024x768x32@60NI

2.5 Peripheral Device Interfaces, Connectors, and Slots

The peripheral device connectors, interfaces and slots on the 3302160 motherboard are listed in the sections below.

2901270 Flat Panel PC

2.5.1 OEM Options

Many of the peripheral device connectors listed below are not connected to any devices. These connectors are reserved for OEM customizations. For a customized option, please contact a GAI sales representative.

2.5.2 Internal Slots

The slots listed below can all be found on the 3302160 motherboard.

- „ 1 x 200-pin DDR SO-DIMM socket
- „ 1 x CFII slot

2.5.3 Internal Peripheral Device Connectors

The peripheral device connectors listed below are located on the 3302160 motherboard. Pinouts for these connectors can be found in **Appendix A**.

- „ 1 x 12V power connector
- „ 1 x ATX power button connector
- „ 1 x ATX power connector
- „ 1 x Audio connector
- „ 1 x CompactFlash® (CF) connector (reverse side)
- „ 1 x DDR SO-DIMM slot
- „ 2 x Fan connectors
- „ 1 x Floppy disk connector
- „ 1 x GPIO connector
- „ 2 x IDE Interface connectors (40-pin and 44-pin)
- „ 1 x Inverter power connector
- „ 1 x IR interface connector
- „ 1 x Keyboard/mouse connector
- „ 1 x LCD LVDS interface Connector
- „ 1 x LED connector
- „ 1 x Parallel port connector
- „ 1 x PCI slot
- „ 2 x Serial port connectors

- „ 1 x RS-232/422/485 serial port connector
- „ 2 x Serial ATA connectors
- „ 1 x USB connector

2.5.4 External Peripheral Device Connectors

The peripheral device connectors listed below are located on the rear panel of the 3302160 motherboard. Pinouts for these connectors can be found in **Appendix A**.

- „ 1 x CRT connector
- „ 1 x Ethernet connector
- „ 1 x PS/2 keyboard/mouse connector
- „ 1 x RS-232 serial port connector
- „ 1 x Reset button
- „ 4 x USB connectors

Installation and Configuration

3.1 Installation Precautions

When installing the flat panel PC, please follow the precautions listed below:

- „ **Power turned off:** When installing the flat panel PC, make sure the power is off. Failing to turn off the power may cause severe injury to the body and/or damage to the system.
- „ **Certified Engineers:** Only certified engineers should install and modify onboard functionalities.
- „ **Mounting:** The flat panel PC is a heavy device. When mounting the system onto a rack, panel, wall or arm please make sure that at least two people are assisting with the procedure.
- „ **Anti-static Discharge:** If a user open the rear panel of the flat panel PC, to configure the jumpers or plug in added peripheral devices, ground themselves first and wear an anti-static wristband.

3.2 Preinstalled Components

The following components are all preinstalled.

- „ Motherboard
- „ TFT LCD screen
- „ Power supply
- „ Dual serial ports with bracket
- „ Dual USB ports with bracket

Preinstalled OEM customizations may include the following.

- „ Resistive type touch screen
- „ DDR 400/333 SO-DIMM memory module
- „ 2.5" HDD
- „ 3.5" HDD
- „ Removable 3.5" HDD
- „ Floppy disk drive
- „ CD drive

Installation of some of the components are described in **the following sections**.

2901270 Flat Panel PC

3.3 Installation and Configuration Steps

The following installation steps must be followed.

- Step 1:** Unpack the flat panel PC
- Step 2:** Set the jumper settings
- Step 3:** Install CPU and CPU cooler
- Step 4:** Install SO-DIMM memory module
- Step 5:** Install HDD and CD drive
- Step 6:** Mount the flat panel PC
- Step 7:** Connect peripheral devices to the bottom panel of the flat panel PC
- Step 8:** Configure the system

3.4 Unpacking

To unpack the flat panel PC, follow the steps below:



WARNING!

The front side LCD screen has a protective plastic cover stuck to the screen. Only remove the plastic cover after the flat panel PC has been properly installed. This ensures the screen is protected during the installation process.

-
- Step 1:** Use box cutters, a knife or a sharp pair of scissors that seals the top side of the external (second) box.
 - Step 2:** Open the external (second) box.
 - Step 3:** Use box cutters, a knife or a sharp pair of scissors that seals the top side of the internal (first) box.

2901270 Flat Panel PC

Step 4: Lift the monitor out of the boxes.







Step 5: Remove both polystyrene ends, one from each side.

Step 6: Pull the plastic cover off the flat panel PC.





Step 7: Make sure all the components listed in the packing list are present.

3.4.1 Packing List

The flat panel PC is shipped with the following components:

Quantity	Item	Image
1	CD-ROM installation kit	
1	CPU cooler	
1	FFC cable	
2	HDD SATA cable	
1	Jumper pack	
10	Panel mounting clamps	
1	Power cord	

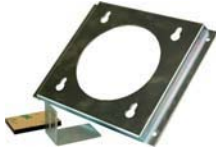
2901270 Flat Panel PC

Quantity	Item	Image
1	PS2 keyboard/mouse Y-cable	
1	RS-232 cable	
1	Screw kit	
1	User manual and driver CD	
1	Wall mounting kit	
1	Touch screen driver CD (Touch Screen models only)	
1	Touch pen (Touch Screen models only)	

If any of these items are missing or damaged, contact the distributor or sales representatives immediately.

3.5 Jumper Settings

**NOTE:**

These jumper settings and the jumper locations are described in detail in the User Manual that came with the 3302160 motherboard. Please refer to this manual for a more detailed understanding of the jumper settings

**NOTE:**

A jumper is a metal bridge used to close an electrical circuit. It consists of two or three metal pins and a small metal clip (often protected by a plastic cover) that slides over the pins to connect them. To CLOSE/SHORT a jumper means connecting the pins of the jumper with the plastic clip and to OPEN a jumper means removing the plastic clip from a jumper.

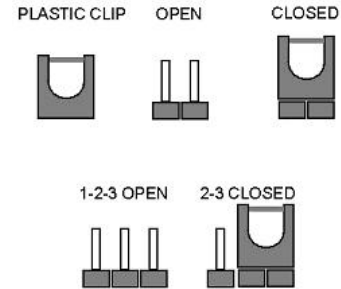

Figure 3-1: Jumper Locations

2901270 Flat Panel PC

The 3302160 comes with six jumpers. They are listed below.

- „ Clear CMOS (J5)
- „ CPU FSB setting (J2)
- „ CPU frequency setting (J1)
- „ CF card setup (J3)
- „ LCD voltage setup (JP1)
- „ COM2 setup (RS-232/485) (J4)

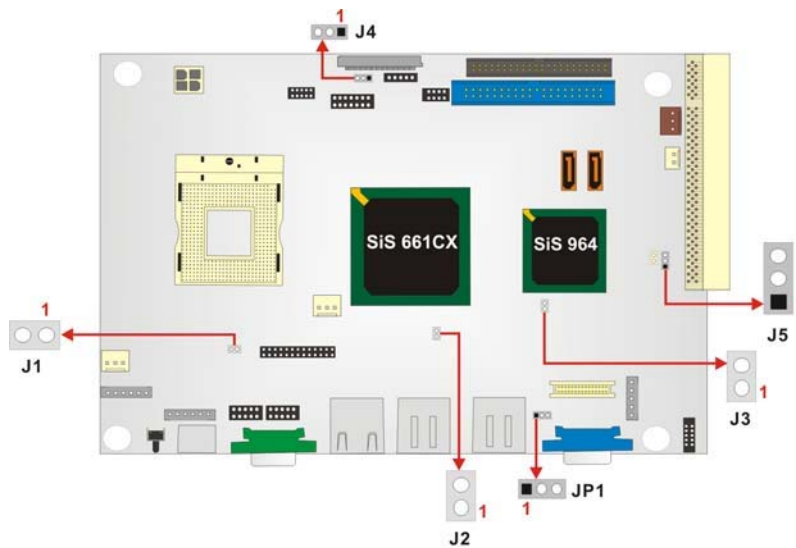

Figure 3-2: Motherboard Jumper Locations

3.5.1 Open the Back Cover

3.5.1.1 2901270 Back Cover Removal

The back cover of the 2901270 is secured to the chassis with ten retention screws on the back panel (**Figure 3-3**). Remove the retention screws and open the cover.

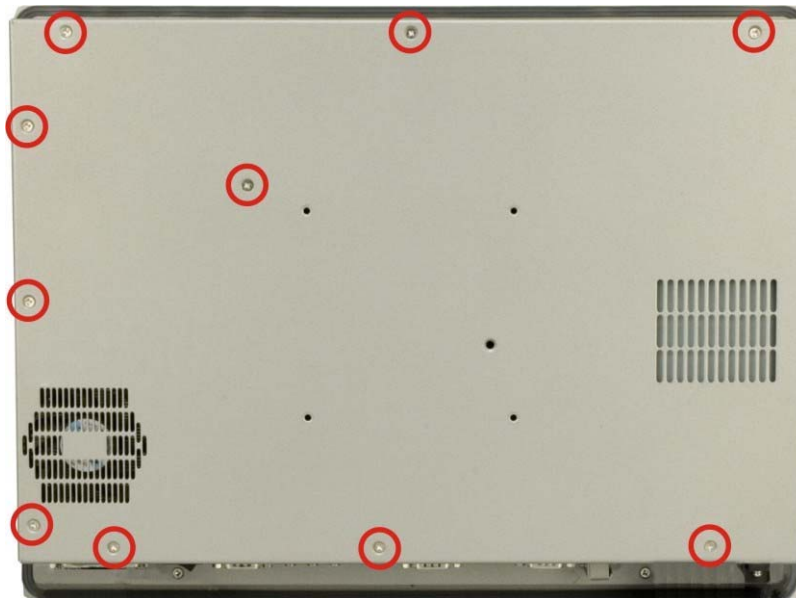

Figure 3-3: 2901270 Back Cover Retention Screws

3.5.2 CPU FSB Settings Jumper

The CPU FSB Settings jumper allows the user to select the front side bus frequency between the CPU and the northbridge.

J2	DESCRIPTION
OPEN	(Default)
CLOSE	FSB 533MHz

Table 3-1: FSB Selection Jumper Settings

2901270 Flat Panel PC

3.5.3 CPU Frequency Setting Jumper

The CPU Frequency Setting jumper allows the user to select the CPU operating speed.

J1	DESCRIPTION
OPEN	100MHz (Default)
CLOSE	133MHz

Table 3-2: CPU Frequency Jumper Settings

3.5.4 CF Card Setup

The CF Card Setup jumper sets the compact flash card as either the slave device or the master device.

J3	DESCRIPTION
OPEN	Slave (Default)
CLOSE	Master

Table 3-3: CF Card Setup Jumper Settings

3.5.5 LCD Voltage Setup Jumper



WARNING!

Making the wrong setting on this jumper may cause irreparable damage to both the motherboard and the LCD screen connected to the onboard connector.

This jumper allows the user to set the voltage for the LCD panel. Before setting this jumper please refer to the LCD panel user guide to determine the required voltage. After the required voltage is known, make the necessary jumper setting in accordance with the settings shown in **Table 3-4**.

JP1	DESCRIPTION
Short 1-2	3V (Default)
Short 2-3	5V

Table 3-4: JP1 Jumper Settings

3.5.6 COM2 Setup Jumper

This jumper configures the COM2 connector as an RS-232 serial port or as an RS-485 serial port. The selection options are shown in **Table 3-5**.

J4	DESCRIPTION
Short 1 – 2	RS-232 (Default)
Short 2 – 3	RS-485

Table 3-5: CON1 Jumper Settings

3.6 CPU and CPU Cooler Installation

3.6.1 CPU Installation



WARNING!

CPUs are expensive and sensitive components. When installing the CPU, please be careful not to damage it in anyway. Make sure to install it properly and ensure that a heat sink and CPU cooling fan is properly installed before running the CPU card or else both the CPU and the board will be damaged.

To install an Intel® 479-pin CPU onto the motherboard, follow the steps below:

- Step 1: Unlock the CPU retention screw.** When shipped, the retention screw of the CPU socket should be in the unlocked position. If it is not in the unlocked position, use a screwdriver to reposition the screw in an unlocked position (**Figure 3-4**).

2901270 Flat Panel PC

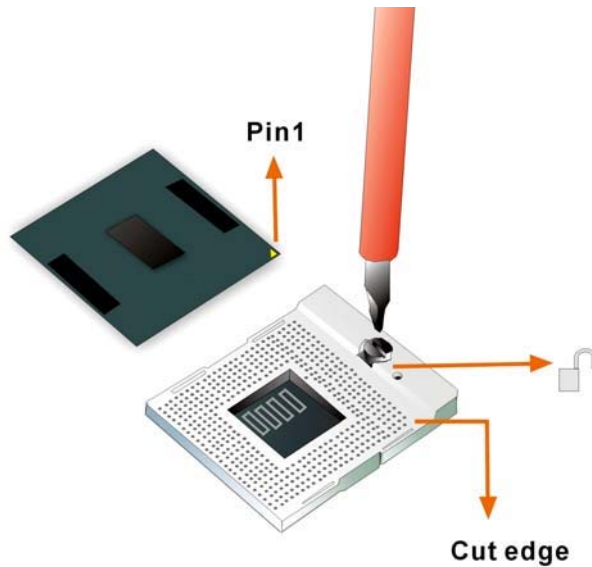

Figure 3-4: Make sure the CPU socket retention screw is unlocked

- Step 2: Inspect the CPU socket** Make sure there are no bent pins and make sure the socket contacts are free of foreign material. If any debris is found, remove it with compressed air.
- Step 3: Orientate the CPU properly.** Make sure the IHS (Integrated Heat Sink) side is facing upward.
- Step 4: Correctly position the CPU.** Match the Pin 1 mark with the cut edge on the CPU socket.
- Step 5: Align the CPU pins.** Carefully align the CPU pins with the holes in the CPU socket.
- Step 6: Insert the CPU.** Gently insert the CPU into the socket. If the CPU pins are properly aligned, the CPU should slide into the CPU socket smoothly
- Step 7: Lock the retention screw.** Rotate the retention screw into the locked position (Figure 3-5).

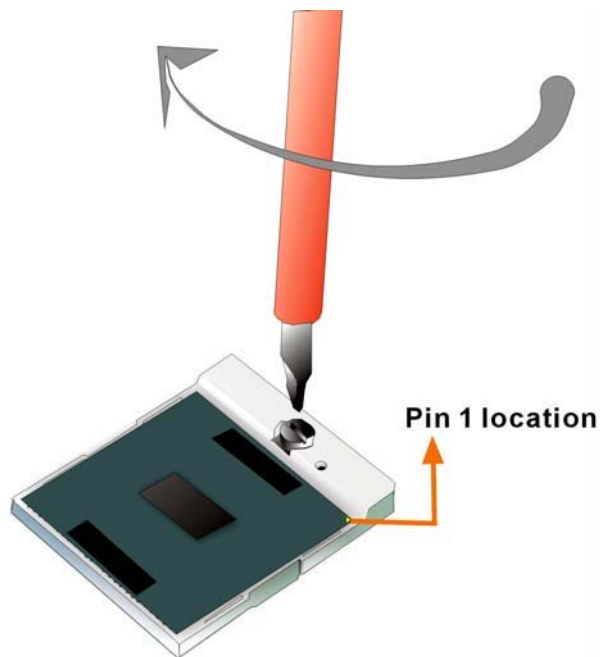

Figure 3-5: Lock the CPU Socket Retention Screw

3.6.2 Cooling Kit Installation

GAI provides a cooling kit designed for socket 479 CPUs. The cooling kit is comprised of a CPU heat sink and a cooling fan. To install the cooling kit, please follow the steps below.

- Step 1:** Place the cooling kit onto the CPU. Make sure that the CPU cable can be properly routed when the cooling kit is installed.
- Step 2:** Properly align the cooling kit. Make sure its four threaded screw fasteners can pass through the pre-drilled holes on PCB.
- Step 3:** Secure the cooling kit. From the solder side of the PCB, align the provided nut caps to the heat sink screw threads that protrude through the PCB holes. Without over tightening the nut caps, insert them onto the protruding screw threads to secure the cooling kit to the PCB board (**Figure 3-6**).

2901270 Flat Panel PC

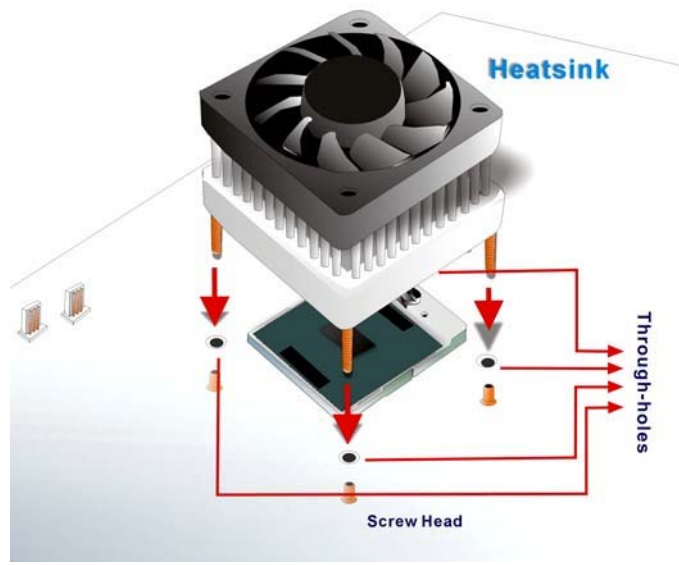

Figure 3-6: Securing the Cooling Kit

Step 4: **Connect the fan cable.** Connect the cooling kit fan cable to the FAN1 connector on the motherboard. Carefully route the cable and avoid heat generating chips and fan blades (Figure 3-7).

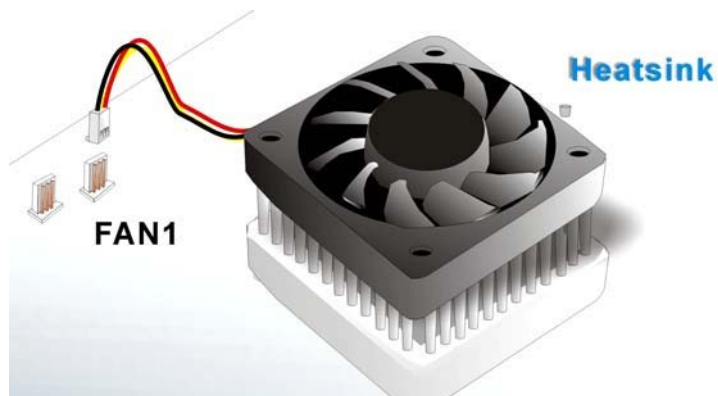

Figure 3-7: Connect the cooling fan cable

3.7 SO-DIMM Module Installation

The flat panel PC has one 200-pin SO-DIMM socket. To install the SO-DIMM module, follow the instructions below.

Step 1: Open the back cover. See **Section 3.5.1** above.

2901270 Flat Panel PC

Step 2: Open the elevated platform. To do this, remove the three retention screws on the bottom panel (**Figure 3-8**).



Figure 3-8: The Elevated Platform Retention Screws

Step 3: Locate the SO-DIMM socket at the underside of the elevated platform (**Figure 3-9**).



Figure 3-9: 2901270 SO-DIMM Socket Location

2901270 Flat Panel PC

- Step 4:** Push the SO-DIMM chip into the socket at an angle (**Figure 3-10**).
- Step 5:** Gently pull the arms of the SO-DIMM socket out and push the rear of the SO-DIMM module down (**Figure 3-10**).
- Step 6:** Release the arms on the SO-DIMM socket. They clip into place and secure the SO-DIMM module in the socket.

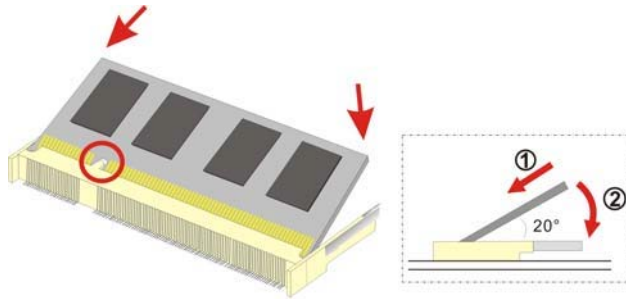

Figure 3-10: SO-DIMM Module Installation

3.8 2.5" HDD Installation

To install the 2.5" HDD into the 2901270, please follow the steps below:

- Step 1:** Open the back cover. See **Section 3.5.1** above.
- Step 2:** Remove the 2.5" HDD bracket from the 2901270. The 2.5" HDD bracket is attached on the 2901270 with four retention screws inside the chassis (**Figure 3-11**). Remove the four retention screws and lift the bracket off the panel PC.

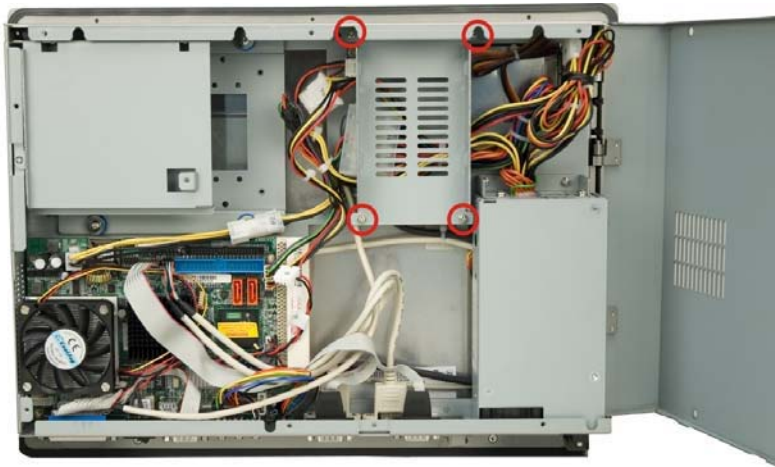

Figure 3-11: 2.5" HDD Bracket Retention Screws

Step 3: Attach the 2.5" HDD bracket to the 2.5" HDD. To do this, align the two retention screw holes in each side of the 2.5" HDD bracket with the retention screw holes on the sides of the HDD. Insert two retention screws into both sides of the 2.5" HDD bracket (**Figure 3-12**). Two 2.5" HDDs can be installed into the HDD bracket.



Figure 3-12: 2.5" HDD Retention Screws

Step 4: Install the HDD into the 2901270 by aligning the retention screw holes in the HDD bracket with the retention screw holes on the panel PC. Insert the four retention screws.

2901270 Flat Panel PC

Step 5: Connect the IDE/SATA cable from the IDE/SATA connector on the motherboard to the rear of HDD.

3.9 CD Drive Installation

To install the CD drive, please follow the steps below:

Step 1: Open the back cover. See **Section 3.5.1** above.

Step 2: The CD drive blank plate assembly is attached to the panel PC by three retention screws, two on the top panel and one inside the chassis (**Figure 3-13**). Remove the three retention screws and lift the CD drive blank plate assembly off the panel PC.

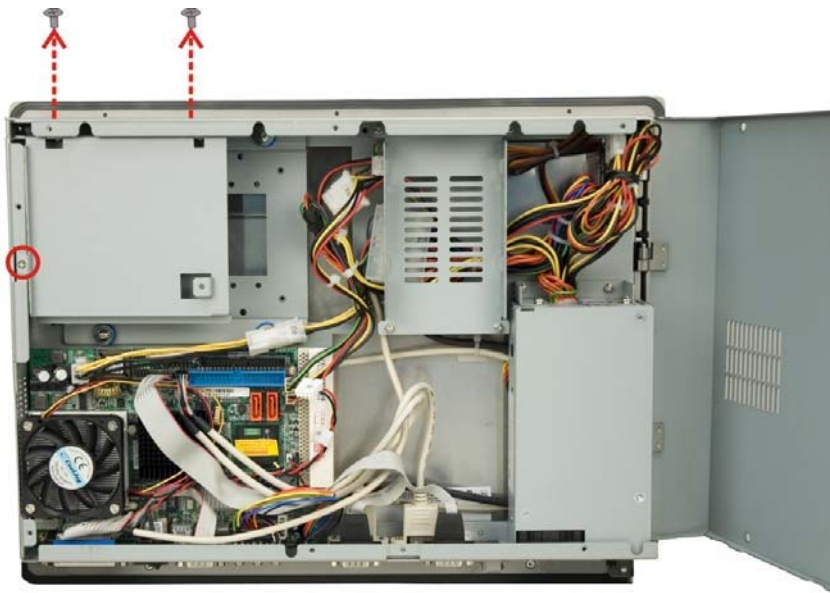

Figure 3-13: CD Drive Retention Screws

Step 3: The CD drive blank plate assembly consists of a blank plate and a bracket. Remove the four screws that attach the brackets to the blank plate (**Figure 3-14**).

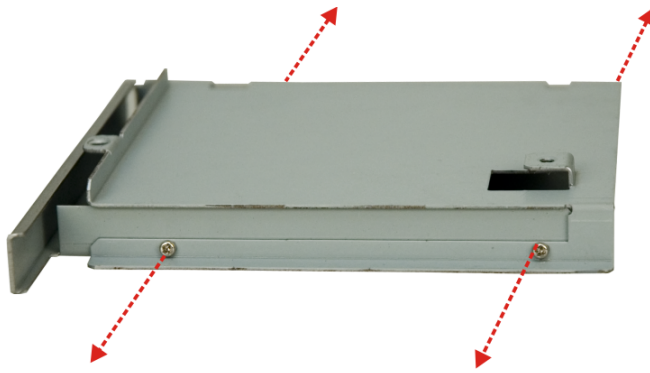

Figure 3-14: CD Drive Blank Plate Assembly

Step 4: Slide the CD drive bracket into the CD drive from the rear of the CD drive and align the two retention screw holes in the side of the CD drive bracket with the retention screw holes on the side of the CD drive. Insert four retention screws to attach the bracket with the CD drive (**Figure 3-15**).

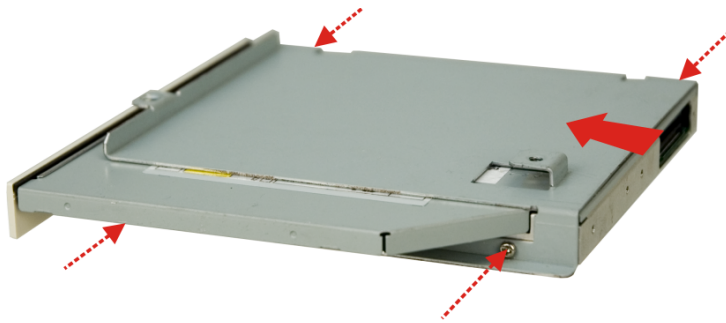

Figure 3-15: CD Drive with Bracket

Step 5: Attach a CD drive adapter to a CD drive by aligning the two retention screw holes in the CD drive adapter with the retention screw holes on the rear side of the CD drive.

Step 6: Place two spacers between the CD drive and CD drive adapter.

Step 7: Insert two retention screws and secure the adapter to the CD drive (**Figure 3-5**)

2901270 Flat Panel PC

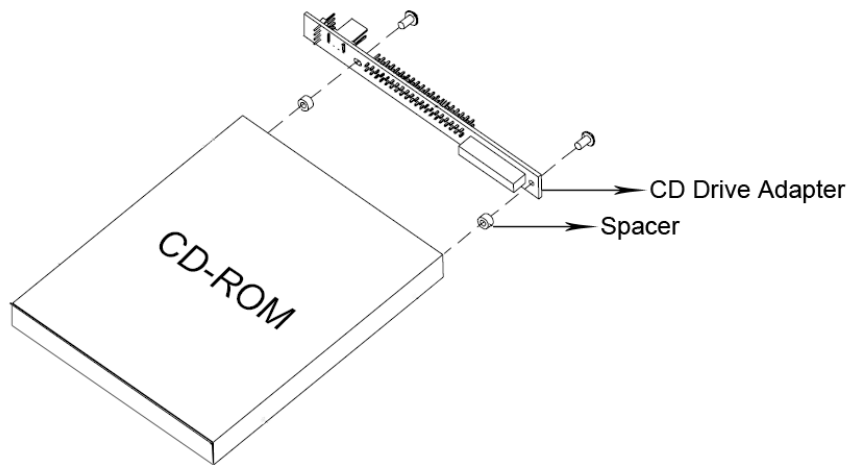

Figure 3-16: CD Drive Adapter Installation

Step 8: Connect the CD ribbon cable and the power cable from the connectors on the motherboard and the PSU to the rear of the CD drive.

Step 9: Install the CD drive into the 2901270 and align the three retention screw holes in the CD drive bracket with the retention screw holes on the panel PC. Reinsert the three previously removed retention screws.

Step 10: When securing the back cover to the chassis, remember to insert the retention screws shown in **Figure 3-17** to secure the CD drive.



Figure 3-17: CD Drive Retention Screw (Rear Panel)

3.10 3.5" HDD Installation

3.10.1 3.5" HDD Installation

To install the 3.5" HDD into the 2901270, please follow the steps below:

- Step 1:** Open the back cover. See **Section 3.5.1** above.
- Step 2:** Remove the CD drive blank plate assembly (see **Step 2** of **Section 3.9**).
- Step 3:** Remove the 3.5" HDD bracket from the 2901270. The 3.5" HDD bracket is attached on the 2901270 with four retention screws inside the chassis (**Figure 3-18**). Remove the four retention screws and lift the bracket off the panel PC.



Figure 3-18: 3.5" HDD Bracket Retention Screws

- Step 4:** Attach the HDD bracket to the HDD. To do this, align the four retention screw holes in the HDD bracket with the retention screw holes on the bottom of the HDD. Insert four retention screws into the HDD bracket. (**Figure 3-19**). Connect the IDE/SATA cable to the rear of the HDD.

2901270 Flat Panel PC



Figure 3-19: 3.5" HDD Retention Screws

Step 5: Install the HDD into the 2901270 by aligning the retention screw holes in the HDD bracket with the retention screw holes on the panel PC. Insert the four retention screws.

Step 6: Connect the IDE/SATA cable from the rear of HDD to the IDE/SATA connector on the motherboard.

3.10.2 Removable 3.5" HDD Installation

To install a removable 3.5" HDD into the 2901270, please follow the steps below:

Step 1: Open the back cover. See **Section 3.5.1** above.

Step 2: Remove the CD drive blank plate assembly (see **Step 2** of **Section 3.9**) and the 3.5" HDD bracket (see **Step 3** of **Section 3.10.1**).

Step 3: Remove the 3.5" HDD bay bracket retention screws on the right panel (**Figure 3-20**) and remove the drive bay bracket.



Figure 3-20: 3.5" HDD Bay Retention Screws

2901270 Flat Panel PC

Step 4: Install a 3.5" HDD to a mobile rack. Please refer to the user manual of the mobile rack for installation procedures.

Step 5: Insert the removable 3.5" HDD with the IDE/SATA cable connected into the panel PC from the right panel (**Figure 3-21**).



Figure 3-21: Removable 3.5" HDD Installation

Step 6: Secure the 3.5" HDD into the 2901270 by aligning the retention screw holes in the removable HDD with the retention screw holes on the bottom of the elevated platform. Insert the four retention screws (**Figure 3-22**).

2901270 Flat Panel PC



Figure 3-22: 3.5" Removable HDD Retention Screws

Step 7: Release the locking mechanism by pushing it into the chassis (**Figure 3-23**) and close the elevated platform.



Figure 3-23: Release Locking Mechanism

Step 8: Connect the IDE/SATA cable from the rear of HDD to the IDE/SATA connector on the motherboard.

3.11 FDD Installation

The user can replace the two removable serial port connectors on the bottom panel with a floppy disk drive. To install a floppy disk drive, follow the steps below:

- Step 1:** Open the back cover. See **Section 3.5.1** above.
- Step 2:** Disconnect the serial port cable from the motherboard.
- Step 3:** Remove the serial port connector bracket from the panel PC by removing the two retention screws on the bottom panel (**Figure 3-24**).



Figure 3-24: Serial Port Connector Retention Screws

- Step 4:** Attach the FDD to the FDD bracket. To do this, align the two retention screw holes in each side of the FDD bracket with the retention screw holes on the sides of the FDD. Insert two retention screws into both sides of the FDD bracket (**Figure 3-25**).

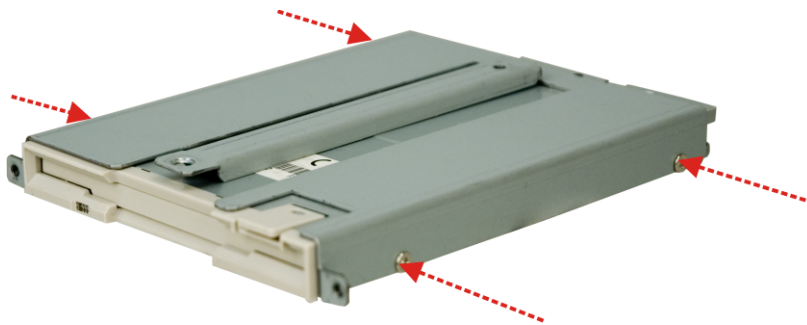

Figure 3-25: FDD Bracket Retention Screws

- Step 5:** Install the FDD into the panel PC by aligning the three retention screw holes in the FDD bracket with the retention screw holes on the bottom panel of the panel PC. Insert the three retention screws (**Figure 3-26**).

2901270 Flat Panel PC

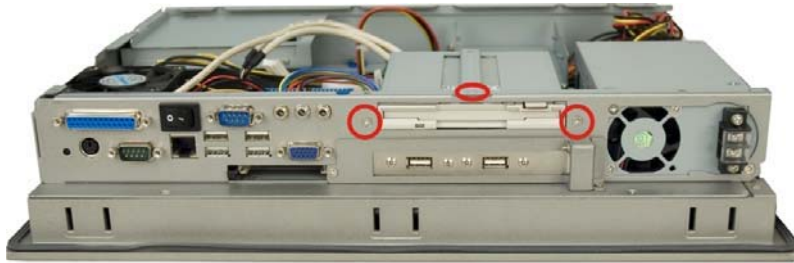

Figure 3-26: FDD Retention Screws (Bottom Panel)

Step 6: Connect the FFC cable to the FDD connector on the motherboard and to the rear of the FDD.

Step 7: When secure the back cover to the chassis, remember to insert the retention screws shown in **Figure 3-27** to secure the FDD.



Figure 3-27: FDD Retention Screw (Rear Panel)

3.12 PCI Card Installation

The user can replace the two removable USB connectors on the bottom panel with a PCI card. To install a PCI card, follow the steps below:

Step 1: Open the back cover. See **Section 3.5.1** above.

Step 2: Disconnect the USB connector cable from the motherboard.

Step 3: Remove the USB connectors and the secured bracket from the panel PC by removing the three retention screws, two on the bottom panel and one on the secured bracket (**Figure 3-28**).



Figure 3-28: USB Port Bracket Retention Screws

Step 4: Insert the PCI card from the bottom panel to the PCI slot on the motherboard (Figure 3-29).



Figure 3-29: PCI Card Installation

Step 5: Secure the PCI card with the secured bracket by insert the three retention screws, two on the bottom panel and one on the secured bracket.

3.13 Mounting the System



WARNING!

When mounting the flat panel PC onto an arm, onto the wall or onto a panel, it is better to have more than one person to help with the installation to make sure the flat panel PC does not fall down and get damaged.

The four methods of mounting the flat panel PC are listed below.

- „ Wall mounting
- „ Panel mounting
- „ Arm mounting
- „ Rack mounting

The four mounting methods are described below.

3.13.1 Wall Mounting

To mount the 2901270 flat panel PC onto a wall, please follow the steps below.

- Step 1:** Select the location on the wall for the wall-mounting bracket.
- Step 2:** Carefully mark the locations of the four bracket screw holes on the wall.
- Step 3:** Drill four pilot holes at the marked locations on the wall for the bracket retention screws.
- Step 4:** Align the wall-mounting bracket screw holes with the pilot holes.
- Step 5:** Secure the mounting-bracket to the wall by inserting the retention screws into the four pilot holes and tightening them (**Figure 3-30**).

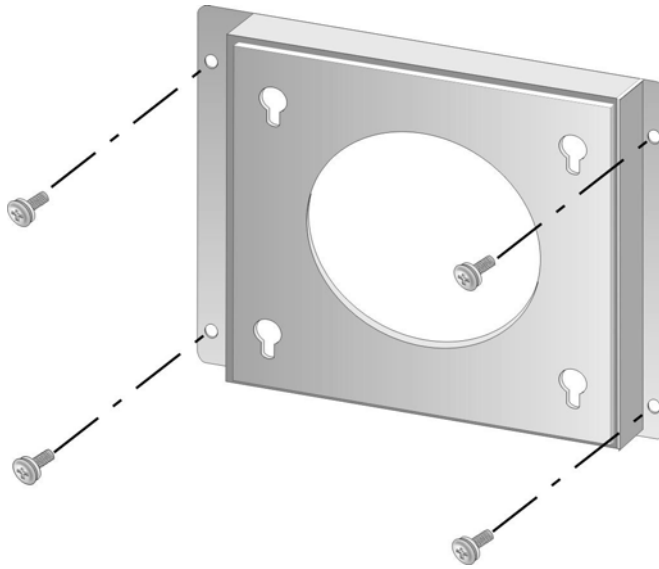

Figure 3-30: Wall-mounting Bracket

Step 6: Insert the four monitor mounting screws provided in the wall mounting kit into the four screw holes on the rear panel of the monitor and tighten until the screw shank is secured against the rear panel (**Figure 3-31**).

Step 1: Align the mounting screws on the monitor rear panel with the mounting holes on the bracket.

Step 2: Carefully insert the screws through the holes and gently pull the monitor downwards until the monitor rests securely in the slotted holes (**Figure 3-31**). Ensure that all four of the mounting screws fit snugly into their respective slotted holes.



NOTE:

In the diagram below the bracket is already installed on the wall.

2901270 Flat Panel PC

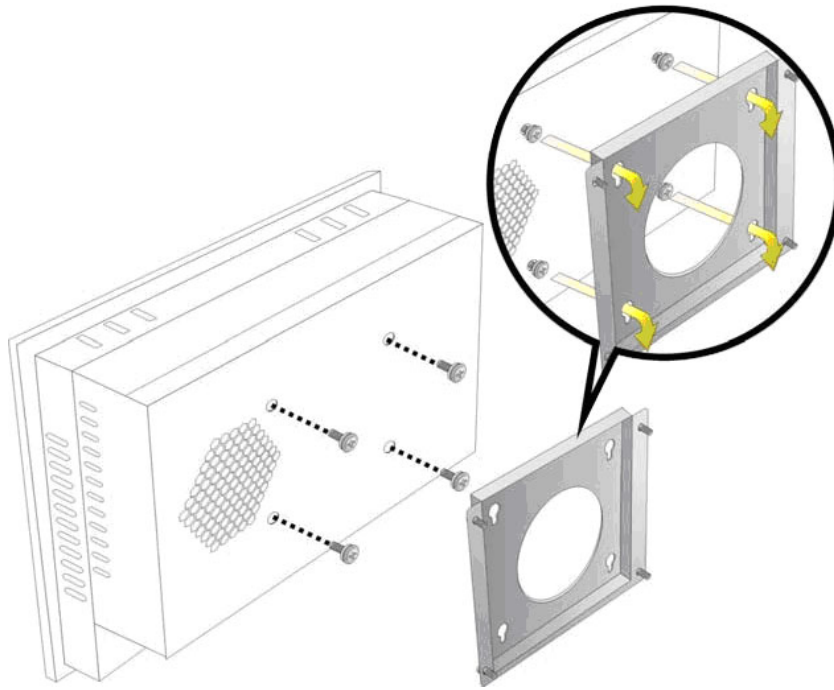

Figure 3-31: Mount the Chassis

Step 3: Secure the panel PC with the wall-mounting kit. To do this, stick the protective cushion to the wall-mounting kit first. Then, put the wall-mounting kit on the top panel of the panel PC. Carefully mark the location of the wall-mounting kit screw holes on the wall. Drill a pilot hole at the marked location on the wall. Secure the wall-mounting kit to the wall by inserting a retention screw into the pilot hole on the wall (**Figure 3-32**). This step is to avoid the panel PC being pushed apart from the wall-mounting bracket accidentally.

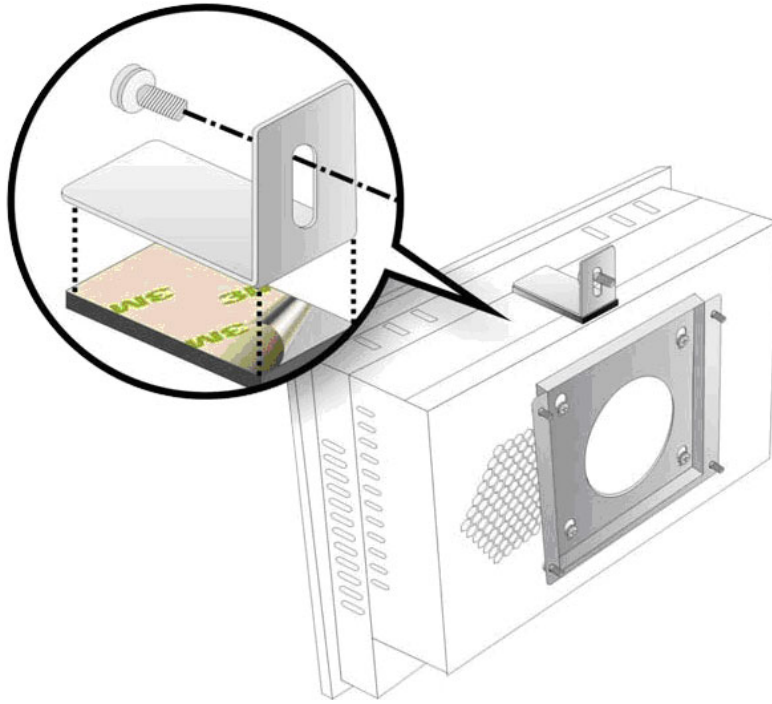

Figure 3-32: Secure the Chassis

3.13.2 Panel Mounting

To mount the 2901270 flat panel PC into a panel, please follow the steps below.

Step 1: Select the position in the panel to mount the 2901270.

Step 2: Cut out a section from the panel that corresponds to the dimensions of the 2901270 flat panel PC chassis. The panel section that is cut out must be smaller than the size of the aluminum frame that surrounds the TFT LCD panel but just large enough for the chassis to fit through. Refer to **Figure 3-33** for the suggested cut out size.

2901270 Flat Panel PC

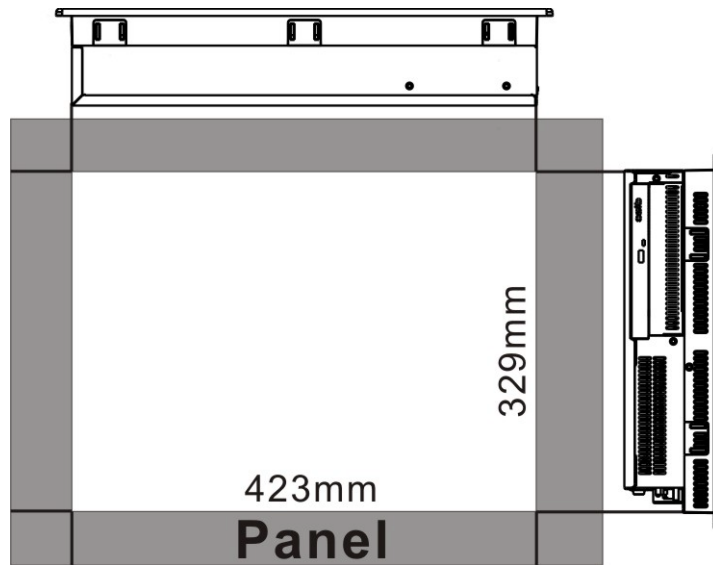

Figure 3-33: Suggested Panel Cut Out Size for 2901270

- Step 3:** Slide the 2901270 flat panel computer through the previously cut hole. The chassis at the rear of the 2901270 flat panel should slide easily through the hole. Only stop sliding the panel through the hole when the back of the front aluminum frame is flush against the panel.
- Step 4:** Insert the panel mounting clamps into the pre-formed holes along the edges of the chassis, behind the aluminum frame. There are a total of 10 panel mounting clamps for 2901270.
- Step 5:** Tighten the screws that pass through the panel mounting clamps until the plastic caps at the front of all the screws are firmly secured to the panel (**Figure 3-34**).

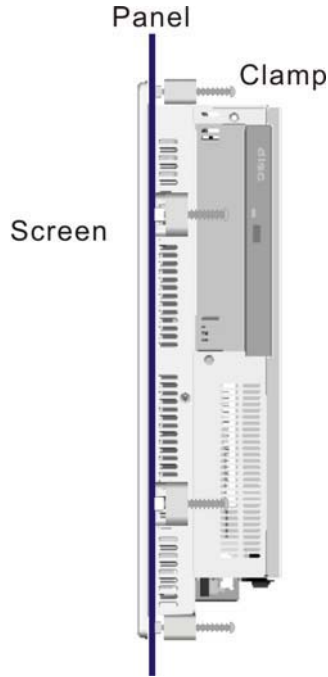

Figure 3-34: Tighten the Panel Mounting Clamp Screws

3.13.3 Arm Mounting

The flat panel PC is VESA (Video Electronics Standards Association) compliant and can be mounted on an arm with a 100mm interface pad. To mount the flat panel PC on an arm, please follow the steps below.

Step 1: The arm is a separately purchased item. Please correctly mount the arm onto the surface it uses as a base. To do this, refer to the installation documentation that came with the mounting arm.



NOTE:

When purchasing the arm please ensure that it is VESA compliant and that the arm has a 100mm interface pad. If the mounting arm is not VESA compliant it cannot be used to support the flat panel PC.

2901270 Flat Panel PC

Step 2: Once the mounting arm has been firmly attached to the surface, lift the flat panel PC onto the interface pad of the mounting arm.

Step 3: Align the retention screw holes on the mounting arm interface with those in the flat panel PC. The flat panel PC arm mount retention screw holes are shown in **Figure 3-35**.

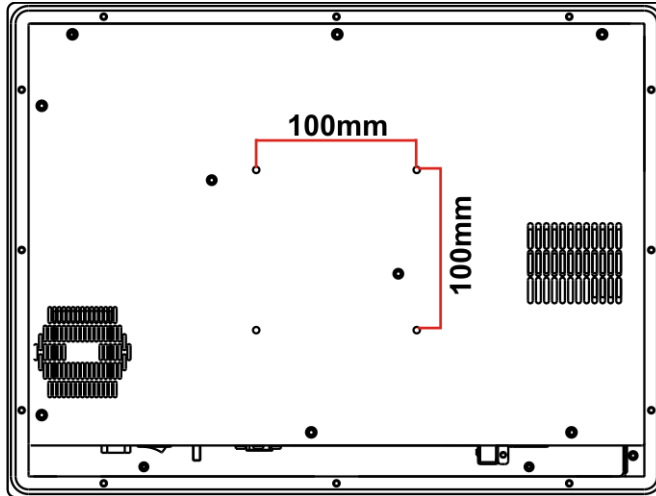

Figure 3-35: Arm Mounting Retention Screw Holes

Step 4: Secure the panel PC to the interface pad by inserting four retention screws through the bottom of the mounting arm interface pad into the flat panel PC.

3.13.4 Cabinet and Rack Installation

The 2901270 flat panel PC can be installed into a cabinet or rack. To do this, please follow the steps below.

Step 1: The back of the aluminum frame surrounding the 2901270 TFT LCD screen has 12 retention screw holes for a cabinet/rack installation bracket.



NOTE:

When purchasing the cabinet/rack installation bracket make sure it is compatible with both the 2901270 flat panel PC and the rack/cabinet into which the 2901270 is installed.

- Step 2:** Slide the rear chassis of the flat panel PC through the rack/cabinet bracket until the rear side of the LCD screen frame is flush against the front of the bracket.
- Step 3:** Make sure the retention screw holes at the rear of the LCD screen are aligned with the retention screw holes in the rack/cabinet bracket.
- Step 4:** Secure the rack/cabinet bracket to the flat panel PC by inserting the appropriate number of retention screws (**Figure 3-36**).

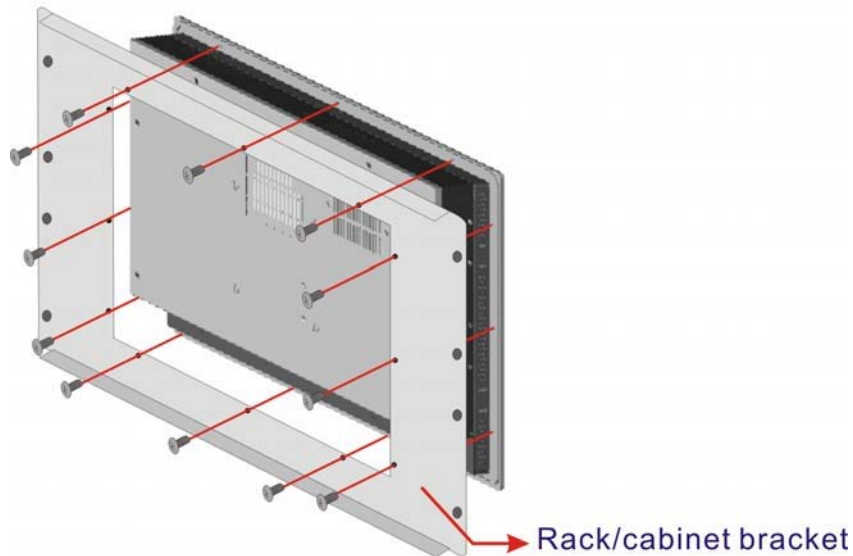

Figure 3-36: Secure the Rack/Cabinet Bracket

- Step 5:** Slide the flat panel PC with the attached rack/cabinet bracket into a rack or cabinet (**Figure 3-37**).

2901270 Flat Panel PC

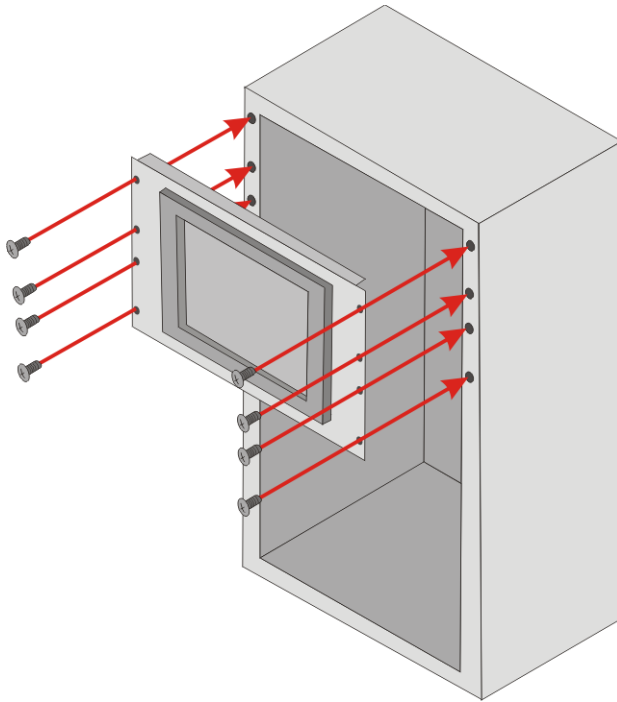

Figure 3-37: Install into a Rack/Cabinet

Step 6: Once the flat panel PC with the attached rack/cabinet bracket has been properly inserted into the rack or cabinet, secure the front of the rack/cabinet bracket to the front of the rack or cabinet (**Figure 3-37**).

3.14 Rear Panel Connectors

3.14.1 LCD Panel Connection

To connect the flat panel PC to a second monitor, a conventional CRT VGA monitor connector is located on the bottom panel. This panel is a 15-pin, female D-SUB connector.

**NOTE:**

To use the dual screen option, please configure this option in the **Intel® Extreme Graphics** configuration program. To do this, after Windows has loaded, open the **Control Panel**, locate the **Intel® Extreme Graphics** icon, click on it. Once open, an option for **Multiple Display** is available. Select this option and select notebook as the primary device.

3.14.2 Ethernet Connection

The rear panel RJ-45 connector can be connected to an external LAN and provide internet connectivity to the flat panel PC.

3.14.3 Serial Ports

The panel PC provides one RS-232 serial port and one RS-232/422/485 serial port on the bottom panel. The serial ports facilitate the connection to serial devices or a communications network, e.g., terminal console. There are two additional RS-232 serial ports with bracket that can be replaced with a floppy disk drive. Please refer to **Section 3.11** for the procedures of FDD installation.

3.14.4 Audio Interface

AC'97 Audio signals are interfaced through three audio jacks on the bottom panel of the 2901270. The signals include line-in stereo, line-out stereo and microphone line-in.



Figure 3-38: Audio Interface

2901270 Flat Panel PC

3.14.5 USB Connections

The 2901270 has four standard and two removable USB 2.0 connectors on the bottom panel. The user can replace the two removable USB connectors with a PCI card. Please refer to **Section 3.12** for the procedures of PCI card installation.

3.14.6 Keyboard and Mouse Connection

Two PS/2 connectors on the bottom panel facilitate the connection of a mouse and a keyboard. To connect either device, plug the PS/2 connector at the end of the device (keyboard or mouse) cable into the PS/2 connector on the bottom panel.

3.14.7 Parallel Port Connector (LPT1)

The onboard parallel port connector connects to a printer. The 2901270 panel PC comes with a multi-mode (ECP/EPP/SPP) parallel port. The parallel port interface features a 26-pin flat-cable connector that requires an adapter cable if a traditional DB-25 connector is used. The parallel port interface can be re-assigned to LPT2 or LPT3 through the BIOS configuration utility. The default interrupt channel is IRQ7. Select ECP or EPP DMA mode using the BIOS configuration utility.

3.15 System Maintenance

If the components of the flat panel PC fail, they must be replaced. Please contact the system reseller or vendor to purchase the replacement parts.



NOTE:

A user cannot replace a motherboard. If the motherboard fails it must be shipped back to GAI to be replaced. Please contact a GAI sales person directly.

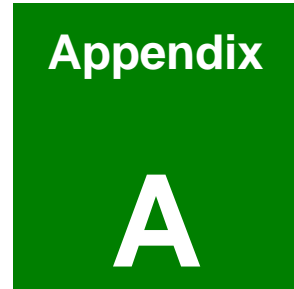

Interface Connectors

2901270 Flat Panel PC

A.1 Peripheral Interface Connectors

The 2901270 flat panel PC motherboard, the 3302160 comes with a number of peripheral interface connectors and configuration jumpers listed in **Chapter 2**. The pinouts for these connectors are listed below:

PIN	DESCRIPTION	PIN	DESCRIPTION
1	GND	2	5V
3	GPO0	4	GPO1
5	GPO2	6	GPO3
7	GPI0	8	GPI1
9	GPI2	10	GPI3

Table A-1: GPIO Connector (DIO1) Pinouts

PIN	DESCRIPTION
1	PWRBTN#
2	GND

Table A-2: Power Button Connector (PWRB1) Pinouts

PIN	DESCRIPTION
1	GND
2	GND
3	+12V
4	+12V

Table A-3: 12V Power Connector (PWR1) Pinouts

PIN	DESCRIPTION	PIN	DESCRIPTION
1	ROUT_L	2	LINR_L
3	GND	4	GND
5	LOUT_L	6	LINL_L
7	GND	8	GND
9	MICIN	10	

Table A-4: Audio Connector (AUDIO1) Pinouts

PIN	DESCRIPTION
1	5VSB
2	PS_ON#
3	GND

Table A-5: ATX Power Connector (PSON1) Pinouts

PIN	DESCRIPTION	PIN	DESCRIPTION
1	GROUND	26	VCC-IN CHECK1
2	DATA 3	27	DATA 11
3	DATA 4	28	DATA 12
4	DATA 5	29	DATA 13
5	DATA 6	30	DATA 14
6	DATA 7	31	DATA 15
7	HDC_CS0#	32	HDC_CS1
8	N/C	33	N/C
9	GROUND	34	IOR#
10	N/C	35	IOW#
11	N/C	36	N/C
12	N/C	37	INTERRUPT
13	VCC_COM	38	VCC_COM
14	N/C	39	CSEL
15	N/C	40	N/C
16	N/C	41	HDD_RESET
17	N/C	42	IORDY

2901270 Flat Panel PC

PIN	DESCRIPTION	PIN	DESCRIPTION
18	SA2	43	N/C
19	SA1	44	VCC_COM
20	SA0	45	HDD_ACTIVE#
21	DATA 0	46	N/C
22	DATA 1	47	DATA 8
23	DATA 2	48	DATA 9
24	N/C	49	DATA 10
25	VCC-IN CHECK2	50	GROUND

Table A-6: CFII Socket Pinouts

PIN	DESCRIPTION
1	Fan Speed Detect
2	+12V
3	GND

Table A-7: Fan Connector (FAN1 & FAN2) Pinouts

PIN	DESCRIPTION	PIN	DESCRIPTION
1	RESET#	2	GROUND
3	DATA 7	4	DATA 8
5	DATA 6	6	DATA 9
7	DATA 5	8	DATA 10
9	DATA 4	10	DATA 11
11	DATA 3	12	DATA 12
13	DATA 2	14	DATA 13
15	DATA 1	16	DATA 14
17	DATA 0	18	DATA 15
19	GROUND	20	N/C
21	IDE DRQ	22	GROUND
23	IOW#	24	GROUND
25	IOR#	26	GROUND
27	IDE CHRDY	28	GROUND
29	IDE DACK	30	GROUND-DEFAULT
31	INTERRUPT	32	N/C
33	SA1	34	N/C
35	SA0	36	SA2
37	HDC CS0#	38	HDC CS1#
39	HDD ACTIVE#	40	GROUND

Table A-8: Primary IDE Connector (IDE1) Pinouts

2901270 Flat Panel PC

PIN	DESCRIPTION	PIN	DESCRIPTION
1	RESET#	2	GROUND
3	DATA 7	4	DATA 8
5	DATA 6	6	DATA 9
7	DATA 5	8	DATA 10
9	DATA 4	10	DATA 11
11	DATA 3	12	DATA 12
13	DATA 2	14	DATA 13
15	DATA 1	16	DATA 14
17	DATA 0	18	DATA 15
19	GROUND	20	N/C
21	IDE DRQ	22	GROUND
23	IOW#	24	GROUND
25	IOR#	26	GROUND
27	IDE CHRDY	28	GROUND
29	IDE DACK	30	GROUND-DEFAULT
31	INTERRUPT	32	N/C
33	SA1	34	N/C
35	SA0	36	SA2
37	HDC CS0#	38	HDC CS1#
39	HDD ACTIVE#	40	GROUND
41	VCC	42	VCC
43	GROUND	44	N/C

Table A-9: Secondary IDE Connector (IDE2) Pinouts

PIN	DESCRIPTION
1	NC
2	GND
3	+12V
4	GND
5	EN_BL

Table A-10: Inverter Connector (INV1) Pinouts

PIN	DESCRIPTION
1	5V
2	N/C
3	IRRX
4	GND
5	IRTX

Table A-11: IR Interface Connector (IR1) Pinouts

PIN	DESCRIPTION
1	GND
2	L_KDAT
3	L_KCLK
4	L_MDAT
5	L_MCLK
6	+5V

Table A-12: Keyboard/Mouse Connector (KBMS1) Pinouts

2901270 Flat Panel PC

PIN	DESCRIPTION
1	+5V
2	GND
3	PWR_LED
4	PWR_LED
5	HDD_LED
6	HDD_LED

Table A-13: LED Connector (LED1) Pinouts

PIN	Description	PIN	Description
1	GND	2	GND
3	Rin0+	4	Rin0-
5	Rin1+	6	Rin1-
7	Rin2+	8	Rin2-
9	CLK1+	10	CLK1-
11	Rin3+	12	Rin3-
13	GND	14	GND
15	Rin4+	16	Rin4-
17	Rin5+	18	Rin5-
19	Rin6+	20	Rin6-
21	CLK2+	22	CLK2-
23	Rin7+	24	Rin7-
25	GND	26	GND
27	LCD_VDD	28	LCD_VDD
29	LCD_VDD	30	LCD_VDD

Table A-14: LVDS Connector (LVDS1) Pinouts

PIN	DESCRIPTION	PIN	DESCRIPTION
1	STROBE#	14	AUTO FORM FEED #
2	DATA0	15	ERROR#
3	DATA1	16	INITIALIZE#
4	DATA2	17	PRINTER SELECT LN#
5	DATA3	18	GND
6	DATA4	19	GND
7	DATA5	20	GND
8	DATA6	21	GND
9	DATA7	22	GND
10	ACKNOWLEDGE#	23	GND
11	BUSY	24	N/C
12	PAPER EMPTY	25	GND
13	PRINTER SELECT		

Table A-15: Parallel Port Connector (LPT1) Pinouts

PIN	DESCRIPTION	PIN	DESCRIPTION
1	5V	14	-STEP
2	-INDEX	15	GND
3	5V	16	-WDATA
4	-DSA	17	GND
5	5V	18	-PWE
6	-DSKCHG	19	GND
7	NC	20	-TRKO
8	NC	21	GND
9	NC	22	-WPT
10	-MOA	23	GND
11	NC	24	-RDATA
12	-DIR	25	GND
13	NC	26	-HSEL

Table A-16: FDD Connector (FDD1) Pinouts

2901270 Flat Panel PC

PIN	DESCRIPTION
1	GND
2	TX0+
3	TX0-
4	GND
5	RX0-
6	RX0+
7	GND

Table A-17: SATA Connector Pinouts

PIN	DESCRIPTION	PIN	DESCRIPTION
1	NDCD3	2	NDSR3
3	NRX3	4	NRTS3
5	NTX3	6	NCTS3
7	NDTR3	8	NRI 3
9	GND	10	GND

Table A-18: COM2 Connector Pinouts

PIN	DESCRIPTION	PIN	DESCRIPTION
1	NDCD4	2	NDSR4
3	NRX4	4	NRTS4
5	NTX4	6	NCTS4
7	NDTR4	8	NRI 4
9	GND	10	GND

Table A-19: COM3 Connector Pinouts

PIN	DESCRIPTION	PIN	DESCRIPTION
1	NDCD2	2	NDSR2
3	NRX2	4	NRTS2
5	NTX2	6	NCTS2
7	NDTR2	8	NRI 2
9	GND	10	GND
11	TX2+	12	TX2-
13	RX2+	14	RX2-

Table A-20: COM4 Connector Pinouts

PIN	DESCRIPTION	PIN	DESCRIPTION
1	USBV3L 5V	2	GND
3	USBP4N	4	USBP5P
5	USBP4P	6	USBP5N
7	GND	8	USBV3L 5V

Table A-21: USB Connector (USB3) Pinouts

2901270 Flat Panel PC

Any advice or comments about our products and service, or anything we can help you with please don't hesitate to contact with us. We will do our best to support you for your products, projects and business.

Global American Inc.

Address: 17 Hampshire Drive
Hudson, NH 03051

TEL: Toll Free (U.S. Only) 800-833-8999
(603)886-3900

FAX: (603)886-4545

Website: <http://www.globalamericaninc.com>

E-Mail: salesinfo@globalamericaninc.com

