



User's Manual

2901230, 1201240, & 2901250

Version 1.0

December 2006

2901230/2901240/2901250 Panel PC

Copyrights

This manual is copyrighted and all rights are reserved. It does not allow any non authorization in copied, photocopied, translated or reproduced to any electronic or machine readable form in whole or in part without prior written consent from the manufacturer.

In general, the manufacturer will not be liable for any direct, indirect, special, incidental or consequential damages arising from the use of inability to use the product or documentation, even if advised of the possibility of such damages. The manufacturer keeps the rights in the subject to change the contents of this manual without prior notices in order to improve the function design, performance, quality and reliability. The author assumes no responsibility for any errors or omissions, which may appear in this manual, nor does it make a commitment to update the information contained herein.

Trademarks

Intel is a registered trademark of Intel Corporation.

Award is a registered trademark of Award Software, Inc.

All other trademarks, products and or product's name mentioned herein are mentioned for identification purposes only, and may be trademarks and/or registered trademarks of their respective companies or owners.

2901230/2901240/2901250 Panel PC

PACKING LIST

Before installing the Panel PC, please make sure that the following items have been shipped:

- „ 1 x HDD IDE cable
- „ 1 x Jumper pack
- „ 1 x Panel mounting kit
- „ 1 x Power cord
- „ 1 x PS2 keyboard/mouse Y-cable
- „ 1 x Screw kit
- „ 1 x User manual and driver CD
- „ 1 x Wall mounting kit
- „ 1 x Slim CD-ROM installation kit (2901250 only)
- „ 1 x 80W power adapter for socket type
- „ 1 x 60W power adapter for BGA type
- „ 1 x Touch screen driver CD (touch screen models only)
- „ 1 x Touch pen (touch screen models only)

If any of these items are missing or damaged, contact the distributor or sales representative immediately.

PRECAUTIONS

SAFETY PRECAUTIONS

1. Prior to installing, moving, and modifying the panel PC, make sure that the unit's power is turned off and the power cord is disconnected.
2. Do not apply voltage levels that exceed the specified voltage range. Doing so may cause fire or an electrical shock.
3. Electric shock can occur if the panel is opened. Do not drop or insert any objects into the ventilation openings of the panel PC.
4. Only qualified engineers from certified system integrators or VARs are allowed to make necessary functional modifications to the panel PC, e.g., adding a touch screen. Global American, Inc. offers the customization service on a pre-order basis

2901230/2901240/2901250 Panel PC

5. If considerable amount of dust, water, or fluids entered the panel PC, turn off the power supply immediately, unplug the power cord, and contact the vendor.
6. Explosions may occur with installations in environments where flammable gases are present.
7. Fault-tolerant and failsafe designs should be implemented with the use of the series models on transportation vehicles, ships, safety/security devices, or medical devices not related to life-support functionalities. Users/integrators should take the responsibility for implementations with adequate levels of reliability and safety.
8. Preventive designs should be implemented so as to avoid the communications faults between the panel PC and the PC/workstation/terminals that controls it.

HANDLING PRECAUTIONS

1. Do not drop the panel PC against a hard surface. Doing so may damage the display.
2. Do not strike or exert excessive force onto the touch panel.
3. Touching the touch panel using a sharp object may damage the LCD panel.
4. Avoid environments exposed to direct sunlight, dust, or chemical vapors.
5. The panel PC is actively cooled. In no circumstances should the panel PC operate with the openings obstructed by foreign objects. However, the ambient temperature of the installation site should be observed and controlled to avoid overheating the panel PC.
6. Condensation might form inside the panel PC chassis if exposed to sudden changes in temperature.
7. Carefully route the power cord so that people cannot step on it. Do not place anything over the power cord.
8. If the equipment should be left unused for an extended period of time, disconnect it from the power source to avoid damage by transient over-voltage.
9. If any of the following situations arises, get the equipment checked by service personnel:
 - The power cord or plug is damaged.
 - Liquid has penetrated into the equipment.

2901230/2901240/2901250 Panel PC

- The equipment has been exposed to moisture.
- The equipment does not work properly, or the user cannot get it to work according to the user manual.
- The equipment has been dropped and damaged.
- The equipment shows obvious signs of breakage.



WARNING!

Any changes or modifications made to the equipment that are not expressly approved by the relevant standards could void the authority to operate the equipment.

ADDITIONAL INFORMATION

MAINTENANCE AND CLEANING

Note the following precautions before beginning to clean the Panel PC.

When cleaning any single part or component of the computer, please read and understand the details below fully.

- „ Except for the properly installed front LCD panel, never spray or squirt liquids directly onto any computer component. To clean the device, please rub it with a piece of dry and soft cloth or a slightly moistened cloth with the exterior casing.
- „ The interior of the Panel PC does not require cleaning. Keep fluids away from the Panel PC and the interior of it.
- „ Be cautious of the tiny removable components when using a vacuum cleaner to absorb the dirt on the floor.
- „ Turn the system off before cleaning up the Panel PC.
- „ Never drop any tiny objects through the openings of the Panel PC or get circuit board damp or wet.
- „ Be cautious of all kinds of cleaning solvents or chemicals when using it for the sake of cleaning. Some individuals may be allergic to the ingredients.
- „ Avoid any food, drink or cigarette around the Panel PC.

CLEANING TOOLS

Although many companies have created products to help improve the process of cleaning the computer and peripherals, users can also use household items to clean their computers and peripherals. Below is a list of items to use while cleaning the computer or computer peripherals.

Please keep in mind that some components in the computer may only be cleaned using a product designed for cleaning that component, if this is the case it will be mentioned in the cleaning tips.

- „ **Cloth** - A piece of cloth is the best tool to use when rubbing up a component. Although paper towels or tissues can be used on most hardware as well, it is recommended to rub it with a piece of cloth.
- „ **Water or rubbing alcohol** – Moisten a piece of cloth a bit with some water or rubbing alcohol and rub it on the computer.
- „ Unknown solvents may be harmful to the plastics parts.
- „ **Vacuum cleaner** - Absorb the dust, dirt, hair, cigarette particles, and other particles out of a computer can be one of the best methods of cleaning a computer. Over time these items can restrict the airflow in a computer and cause circuitry to corrode.
- „ **Cotton swabs** - Cotton swabs moistened with rubbing alcohol or water are excellent tools for wiping hard to reach areas in the keyboard, mouse, and other locations.
- „ **Foam swabs** - Whenever possible it is better to use lint free swabs such as foam swabs.

ESD PRECAUTIONS

Observe all conventional anti-ESD methods while handling the components contained within the LCD should the need arise for adding a functionality. The use of a grounded wrist strap and an anti-static work pad is recommended. Avoid dust and debris or other static-accumulating materials in the work area.

MANUAL CONVENTIONS



WARNING!

Warnings appear where overlooked details may cause damage to the equipment or result in personal injury. Warnings should be taken seriously. Warnings are easy to recognize. The word “warning” is written as “**WARNING**,” both capitalized and bold and is followed by text in italics. The italicized text is the warning message.



CAUTION!

Cautionary messages should also be heeded to reduce the chance of losing data or damaging the system. Cautions are easy to recognize. The word “caution” is written as “**CAUTION**,” both capitalized and bold and is followed by text in italics. The italicized text is the cautionary message.



NOTE:

These messages inform the reader of essential but non-critical information. These messages should be read carefully as any directions or instructions contained therein can avoid making mistakes. Notes are easy to recognize. The word “note” is written as “**NOTE**,” both capitalized and bold and is followed by text in italics. The italicized text is the cautionary message.

Lists

Bulleted Lists: Bulleted lists are statements of non-sequential facts that can be read in any order. Each statement is preceded by a black square “□” or bullets in other shapes.

Numbered Lists: Numbered lists describe sequential steps should be followed in order.

Table of Contents

1	INTRODUCTION.....	15
1.1	OVERVIEW	16
1.1.1	<i>Model Variation.....</i>	<i>16</i>
1.1.1.1	2901230 Variation.....	16
1.1.1.2	2901240 Variation.....	17
1.1.1.3	2901250 Variation.....	18
1.1.2	<i>Applications</i>	<i>19</i>
1.1.3	<i>Features</i>	<i>19</i>
1.2	EXTERNAL OVERVIEW	20
1.2.1	<i>General Description.....</i>	<i>20</i>
1.2.2	<i>Front Panel</i>	<i>20</i>
1.2.3	<i>Rear Panel</i>	<i>21</i>
1.2.4	<i>Bottom Panel.....</i>	<i>21</i>
1.2.4.1	2901230 Bottom Panel	21
1.2.4.2	2901240 Bottom Panel	22
1.2.4.3	2901250 Bottom Panel	23
1.2.5	<i>Side Panel</i>	<i>24</i>
1.2.6	<i>Frame</i>	<i>24</i>
1.3	SPECIFICATIONS	25
1.3.1	<i>Preinstalled Hardware Components.....</i>	<i>25</i>
1.3.2	<i>System Specifications.....</i>	<i>26</i>
1.3.3	<i>Motherboard Specifications.....</i>	<i>27</i>
1.3.4	<i>Flat Panel Screen Specifications</i>	<i>28</i>
1.3.4.1	2901230 Flat Panel Screen	28
1.3.4.2	2901240 Flat Panel Screen	29
1.3.4.3	2901250 Flat Panel Screen	30
1.3.5	<i>Power Adapter Specifications.....</i>	<i>31</i>
1.3.5.1	80W Power Adapter	31
1.3.5.2	60W Power Adapter	33
1.3.6	<i>Power Module Specifications</i>	<i>34</i>

2901230/2901240/2901250 Panel PC

1.4 DIMENSIONS	36
1.4.1 2901230 Dimensions.....	36
1.4.2 2901240 Dimensions.....	37
1.4.3 2901250 Dimensions.....	38
2 3302150 MOTHERBOARD.....	39
2.1 INTRODUCTION	40
2.2 CPU SUPPORT.....	40
2.3 ONBOARD CHIPSETS	40
2.3.1 Northbridge and Southbridge Chipsets	40
2.3.2 852GM Northbridge Chipset	40
2.3.3 ICH4 Southbridge Chipset.....	41
2.4 GRAPHICS SUPPORT	42
2.5 PERIPHERAL DEVICE INTERFACES, CONNECTORS, AND SLOTS.....	43
2.5.1 OEM Options	43
2.5.2 Internal Slots.....	44
2.5.3 Internal Peripheral Device Connectors.....	44
2.5.4 External Peripheral Device Connectors.....	44
3 INSTALLATION AND CONFIGURATION	47
3.1 INSTALLATION PRECAUTIONS.....	48
3.2 PREINSTALLED COMPONENTS	48
3.3 INSTALLATION AND CONFIGURATION STEPS	48
3.4 UNPACKING.....	49
3.4.1 Packing List	50
3.5 JUMPER SETTINGS.....	50
3.5.1 Remove the Back Cover	52
3.5.1.1 2901230 Back Cover Removal.....	52
3.5.1.2 2901240 Back Cover Removal.....	52
3.5.1.3 2901250 Back Cover Removal.....	53
3.5.2 JP1: CF Card Setup.....	53
3.5.3 JP4: Clear CMOS Setup	53
3.5.4 JP6: LCD Voltage Setup	54
3.5.5 JP2: COM Port Jumper Setting.....	54
3.6 CPU AND CPU COOLER INSTALLATION.....	55

2901230/2901240/2901250 Panel PC

3.6.1 CPU Installation	55
3.6.2 Cooling Kit Installation	57
3.7 HDD INSTALLATION	59
3.7.1 2901230 HDD Installation.....	59
3.7.2 2901240 HDD Installation.....	61
3.7.3 2901250 HDD Installation.....	63
3.8 CD DRIVE INSTALLATION (2901250 ONLY)	64
3.9 MOUNTING THE SYSTEM	66
3.9.1 Wall Mounting	66
3.9.2 Panel Mounting.....	69
3.9.2.1 2901230/2901240 Panel Mounting.....	69
3.9.2.2 2901250 Panel Mounting	71
3.9.3 Arm Mounting	73
3.9.4 Cabinet and Rack Installation	74
3.9.4.1 2901230 Cabinet and Rack Installation.....	74
3.9.4.2 2901240/2901250 Cabinet and Rack Installation	76
3.10 REAR PANEL CONNECTORS	77
3.10.1 LCD Panel Connection	77
3.10.2 Ethernet Connection	78
3.10.3 USB Connection.....	78
3.10.4 Keyboard and Mouse Connection.....	78
3.11 SYSTEM MAINTENANCE	78
A INTERFACE CONNECTORS	79
A.1 PERIPHERAL INTERFACE CONNECTORS	80

THIS PAGE IS INTENTIONALLY LEFT BLANK

List of Figures

Figure 1-1: Front View.....	20
Figure 1-2: 2901250 Wall-Mounting Bracket Retention Screw Holes.....	21
Figure 1-3: 2901230 Bottom View	22
Figure 1-4: 2901240 Bottom View	23
Figure 1-5: 2901250 Bottom View	24
Figure 1-6: 2901250 Left View	24
Figure 1-7: 2901240 Frame Rear View (10 panel mount retention screw holes).....	25
Figure 1-8: 2901250 Frame Rear View (8 panel mount retention screw holes).....	25
Figure 1-9: 80W Power Adapter Dimensions	31
Figure 1-10: 60W Power Adapter Dimensions	33
Figure 1-11: 2901230 Dimensions (units in mm).....	36
Figure 1-12: 2901240 Dimensions (units in mm).....	37
Figure 1-13: 2901250 Dimensions (units in mm).....	38
Figure 3-1: Jumper Locations.....	51
Figure 3-2: 2901230 Back Cover Retention Screws	52
Figure 3-3: 2901240 Back Cover Retention Screws	52
Figure 3-4: 2901250 Back Cover Retention Screws	53
Figure 3-5: Make sure the CPU socket retention screw is unlocked.....	56
Figure 3-6: Lock the CPU Socket Retention Screw	57
Figure 3-7: Cooling Kit	57
Figure 3-8: Securing the Cooling Kit.....	58
Figure 3-9: Connect the cooling fan cable	59
Figure 3-10: 2901230 HDD Bracket Retention Screws (Tope Panel).....	60
Figure 3-11: 2901230 HDD Bracket Retention Screws (Inside).....	60
Figure 3-12: 2901230 HDD Retention Screws	60
Figure 3-13: 2901240 HDD Bracket Retention Screws.....	62
Figure 3-14: 2901240 HDD Retention Screws	62
Figure 3-15: 2901250 HDD Bracket Retention Screws.....	63

2901230/2901240/2901250 Panel PC

Figure 3-16: 2901250 HDD Retention Screws	64
Figure 3-17: CD Drive Adapter Installation	64
Figure 3-18: CD Drive Bracket Retention Screws	65
Figure 3-19: 2901250 CD Drive Retention Screws.....	65
Figure 3-20: Wall-mounting Bracket.....	67
Figure 3-21: Mount the Chassis	68
Figure 3-22: Secure the Chassis.....	69
Figure 3-23: Suggested Panel Cut Out Size for 2901230.....	70
Figure 3-24: Suggested Panel Cut Out Size for 2901240.....	70
Figure 3-25: Tighten the Panel Mounting Clamp Screws (2901230/2901240).....	71
Figure 3-26: 2901250 Panel Mounting Kit	71
Figure 3-27: Suggested Panel Cut Out Size for 2901250.....	72
Figure 3-28: Tighten the Panel Mounting Clamp Screws (2901250).....	73
Figure 3-29: Arm Mounting Retention Screw Holes	74
Figure 3-30: The Rack/Cabinet Bracket	75
Figure 3-31: Secure the 2901230 Rack/Cabinet Bracket	75
Figure 3-32: Install into a Rack/Cabinet	76
Figure 3-33: Secure the 2901240/2901250 Rack/Cabinet Bracket.....	77

List of Tables

Table 1-1: 2901230 Model Variation	17
Table 1-2: 2901240 Model Variation	18
Table 1-3: 2901250 Model Variation	19
Table 1-4: System Specifications	27
Table 1-5: Motherboard Specifications	28
Table 1-6: 8.4" TFT LCD Monitor Specifications.....	29
Table 1-7: 10.4" TFT LCD Monitor Specifications.....	30
Table 1-8: 12.1" TFT LCD Monitor Specifications.....	31
Table 1-9: 80W Power Adapter Specifications	33
Table 1-10: 60W Power Adapter Specifications	34
Table 1-11: DC-to-DC Power Module Specifications	35
Table 3-1: CF Card Setup Jumper Settings	53
Table 3-2: Clear CMOS Jumper Settings	54
Table 3-3: LCD Voltage Setup Jumper Settings.....	54
Table 3-4: JP2 Jumper Settings.....	55

Introduction

2901230/2901240/2901250 Panel PC

1.1 Overview

The 2901230/2901240/2901250 flat panel PC is a flexible, multi-functional flat panel PC that can be applied in diverse operational environments and implemented in multi-faceted applications. The 2901230/2901240/2901250 comes fully kitted with a high-performance motherboard and a host of other peripheral interface connectors. The 2901230/2901240/2901250 is designed for ease of use and easy installation.

1.1.1 Model Variation

1.1.1.1 2901230 Model Variation

Sixteen 2901230 models are available. The models are listed in **Table 1-1**.

2901230	CPU	Socket/ BGA	Luminance	Touch screen	Power
A	Pentium M / Celeron M FSB 400MHz	Socket 479	220 cd/m ²	No	80W power adapter
E	Pentium M / Celeron M FSB 400MHz	Socket 479	450 cd/m ²	No	80W power adapter
C	Pentium M / Celeron M FSB 400MHz	Socket 479	220 cd/m ²	No	9~36V DC input
G	Pentium M / Celeron M FSB 400MHz	Socket 479	450 cd/m ²	No	9~36V DC input
B	Pentium M / Celeron M FSB 400MHz	Socket 479	220 cd/m ²	Yes	80W power adapter
F	Pentium M / Celeron M FSB 400MHz	Socket 479	450 cd/m ²	Yes	80W power adapter
D	Pentium M / Celeron M FSB 400MHz	Socket 479	220 cd/m ²	Yes	9~36V DC input
H	Pentium M / Celeron M FSB 400MHz	Socket 479	450 cd/m ²	Yes	9~36V DC input
I	Celeron M 1GHz zero cache	BGA	220 cd/m ²	No	60W power adapter

2901230/2901240/2901250 Panel PC

M	Celeron M 1GHz zero cache	BGA	450 cd/m ²	No	60W power adapter
K	Celeron M 1GHz zero cache	BGA	220 cd/m ²	No	9~36V DC input
O	Celeron M 1GHz zero cache	BGA	450 cd/m ²	No	9~36V DC input
J	Celeron M 1GHz zero cache	BGA	220 cd/m ²	Yes	60W power adapter
N	Celeron M 1GHz zero cache	BGA	450 cd/m ²	Yes	60W power adapter
L	Celeron M 1GHz zero cache	BGA	220 cd/m ²	Yes	9~36V DC input
P	Celeron M 1GHz zero cache	BGA	450 cd/m ²	Yes	9~36V DC input

Table 1-1: 2901230 Model Variation

1.1.1.2 2901240 Model Variation

Sixteen 2901240 models are available. The models are listed in **Table 1-2**.

2901240	CPU	Socket/ BGA	Luminance	Touch screen	Power
A	Pentium M / Celeron M FSB 400MHz	Socket 479	220 cd/m ²	No	80W power adapter
E	Pentium M / Celeron M FSB 400MHz	Socket 479	450 cd/m ²	No	80W power adapter
C	Pentium M / Celeron M FSB 400MHz	Socket 479	220 cd/m ²	No	9~36V DC input
G	Pentium M / Celeron M FSB 400MHz	Socket 479	450 cd/m ²	No	9~36V DC input
B	Pentium M / Celeron M FSB 400MHz	Socket 479	220 cd/m ²	Yes	80W power adapter
F	Pentium M / Celeron M FSB 400MHz	Socket 479	450 cd/m ²	Yes	80W power adapter

2901230/2901240/2901250 Panel PC

2901240	CPU	Socket/ BGA	Luminance	Touch screen	Power
D	Pentium M / Celeron M FSB 400MHz	Socket 479	220 cd/m ²	Yes	9~36V DC input
H	Pentium M / Celeron M FSB 400MHz	Socket 479	450 cd/m ²	Yes	9~36V DC input
I	Celeron M 1GHz zero cache	BGA	220 cd/m ²	No	60W power adapter
M	Celeron M 1GHz zero cache	BGA	450 cd/m ²	No	60W power adapter
K	Celeron M 1GHz zero cache	BGA	220 cd/m ²	No	9~36V DC input
O	Celeron M 1GHz zero cache	BGA	450 cd/m ²	No	9~36V DC input
J	Celeron M 1GHz zero cache	BGA	220 cd/m ²	Yes	60W power adapter
N	Celeron M 1GHz zero cache	BGA	450 cd/m ²	Yes	60W power adapter
L	Celeron M 1GHz zero cache	BGA	220 cd/m ²	Yes	9~36V DC input
P	Celeron M 1GHz zero cache	BGA	450 cd/m ²	Yes	9~36V DC input

Table 1-2: 2901240 Model Variation

1.1.1.3 2901250 Model Variation

Eight 2901250 models are available. The models are listed in **Table 1-3**.

2901250	CPU	Socket/ BGA	Touch screen	Power
A	Pentium M / Celeron M FSB 400MHz	Socket 479	No	80W power adapter

2901230/2901240/2901250 Panel PC

B	Pentium M / Celeron M FSB 400MHz	Socket 479	Yes	80W power adapter
C	Pentium M / Celeron M FSB 400MHz	Socket 479	No	9~36V DC input
D	Pentium M / Celeron M FSB 400MHz	Socket 479	Yes	9~36V DC input
E	Celeron M 1GHz zero cache	BGA	No	60W power adapter
F	Celeron M 1GHz zero cache	BGA	Yes	60W power adapter
G	Celeron M 1GHz zero cache	BGA	No	9~36V DC input
H	Celeron M 1GHz zero cache	BGA	Yes	9~36V DC input

Table 1-3: 2901250 Model Variation

1.1.2 Applications

The flat panel PC is designed for rigorous industrial environments where it may be exposed to both heat and moisture. Its durability and strength also makes it an ideal choice for public access computers. Some possible applications include:

- „ Automated manufacturing processes
- „ Public information gathering point

1.1.3 Features

Some of the standard features of the 2901230/2901240/2901250 flat panel PC include:

- „ Intel Pentium M / Celeron M CPU upto 2.1GHz for socket type
- „ Onboard Celeron M 1GHz zero cache for BGA type
- „ Preinstalled 512MB DDR 400 SODIMM memory module
- „ Aluminum die-casting IP65, high brightness industrial panel
- „ Serial ATA interface support

2901230/2901240/2901250 Panel PC

- „ Gigabit Ethernet support
- „ Simplified installation process
- „ Low power consumption and thermal distribution
- „ RoHS compliance

1.2 External Overview

1.2.1 General Description

The flat panel PC is a rectangular cubic structure that comprises of a screen, rear panel, top panel, bottom panel and two side panels (left and right). An aluminum frame surrounds the front screen. The rear panel provides screw holes for a wall-mounting bracket, and an arm mounting interface. The bottom panel provides access to external interface connectors that include LAN, USB 2.0, audio, VGA, serial port connectors and CF card slot.

1.2.2 Front Panel

The front side of the 2901230/2901240/2901250 is a flat panel TFT LCD screen surrounded by an aluminum frame.

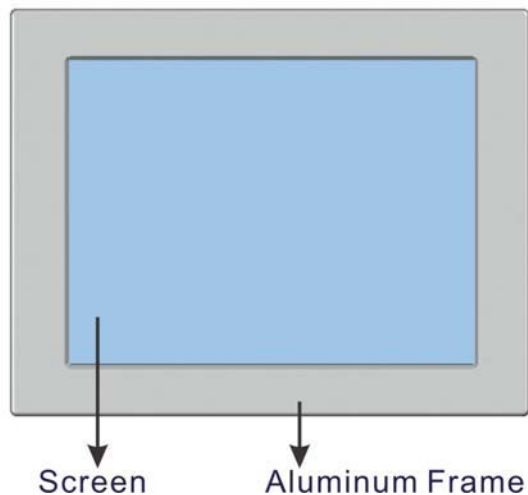

Figure 1-1: Front View

2901230/2901240/2901250 Panel PC

1.2.3 Rear Panel

The rear panel provides access to a fan ventilation vent and four retention screw holes that support a wall-mounting bracket. **Figure 1-2** shows the retention screw holes of the 2901250.

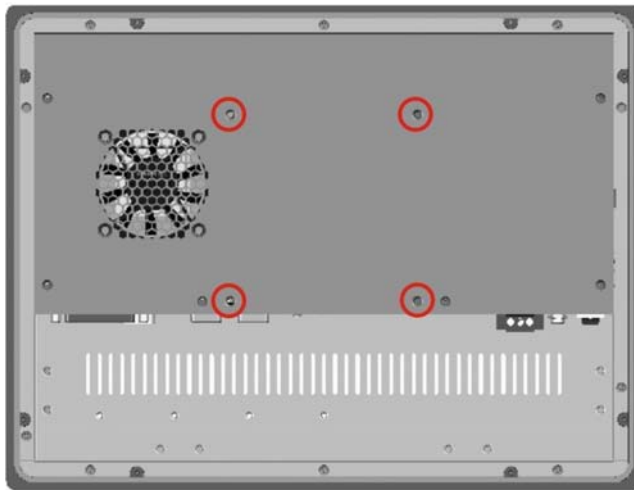

Figure 1-2: 2901250 Wall-Mounting Bracket Retention Screw Holes

1.2.4 Bottom Panel

All peripheral device connectors are located on the bottom panel of the flat panel PC. The following sections describe the bottom panel variants.

1.2.4.1 2901230 Bottom Panel

The following is a list of the bottom panel peripheral device connectors used on the 2901230 flat panel PC. The **Figure 1-3** shows the location of these connectors.

- „ 1 x RS-232/422/485 port
- „ 2 x RS-232 ports
- „ 3 x Audio jacks (Line-in, Line-out and MIC-in)
- „ 1 x PS/2 keyboard/mouse connector
- „ 1 x AC power adapter connector
- „ 1 x VGA connector
- „ 1 x RJ-45 GbE connector

2901230/2901240/2901250 Panel PC

- „ 4 x USB 2.0 connectors
- „ 1 x Compact Flash slot
- „ 1 x 9~36V DC input connector (optional)
- „ 1 x Power switch

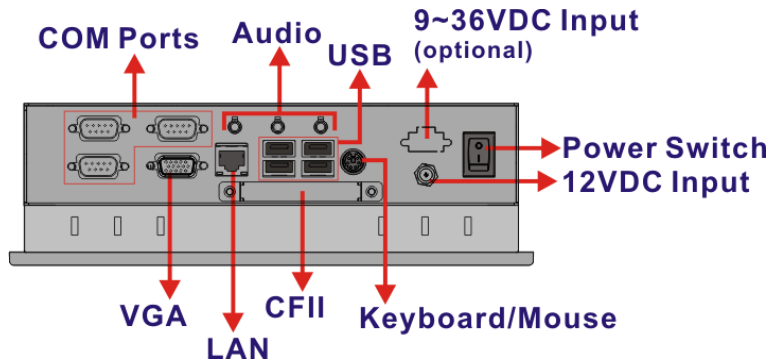

Figure 1-3: 2901230 Bottom View

1.2.4.2 2901240 Bottom Panel

The following is a list of the bottom panel peripheral device connectors used on the 2901240 flat panel PC. The **Figure 1-4** shows the location of these connectors.

- „ 1 x RS-232/422/485 port
- „ 2 x RS-232 ports
- „ 3 x Audio jacks (Line-in, Line-out and MIC-in)
- „ 1 x PS/2 keyboard/mouse connector
- „ 1 x AC power adapter connector
- „ 1 x VGA connector
- „ 1 x RJ-45 GbE connector
- „ 4 x USB 2.0 connectors
- „ 1 x Compact Flash slot
- „ 1 x 9~36V DC input connector (optional)
- „ 1 x Power switch

2901230/2901240/2901250 Panel PC

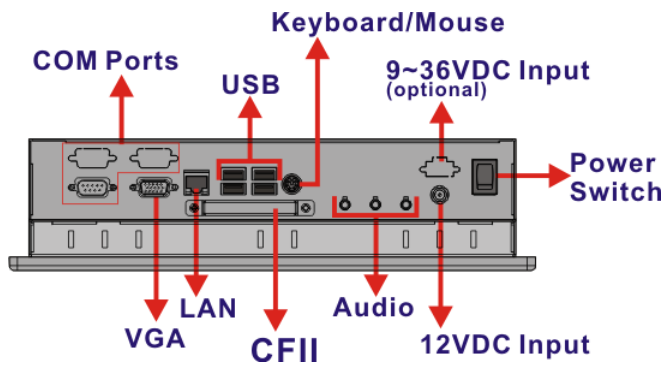

Figure 1-4: 2901240 Bottom View

1.2.4.3 2901250 Bottom Panel

The following is a list of the bottom panel peripheral device connectors used on the 2901250 flat panel PC. The **Figure 1-5** shows the location of these connectors.

- „ 1 x Parallel port connector
- „ 1 x RS-232/422/485 port
- „ 3 x RS-232 ports
- „ 3 x Audio jacks (Line-in, Line-out and MIC-in)
- „ 1 x PS/2 keyboard/mouse connector
- „ 1 x AC power adapter connector
- „ 1 x VGA connector
- „ 1 x RJ-45 GbE connector
- „ 4 x USB 2.0 connectors
- „ 1 x Compact Flash slot
- „ 1 x 9~36V DC input connector (optional)
- „ 1 x Power switch

2901230/2901240/2901250 Panel PC

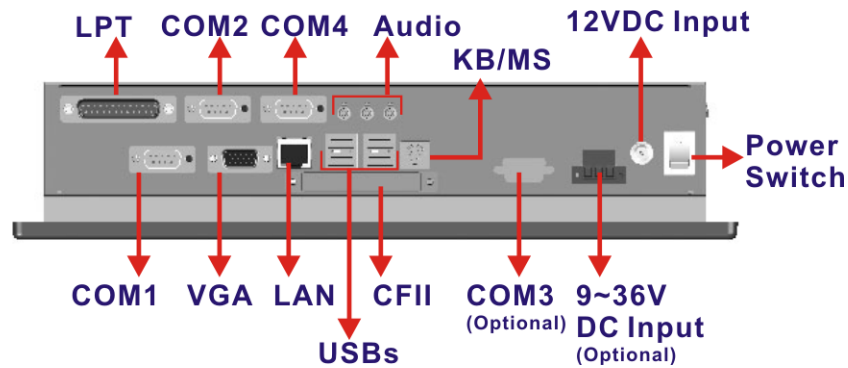

Figure 1-5: 2901250 Bottom View

1.2.5 Side Panel

The both sides panel of the flat panel PC contain some vents for ventilation. The left side panel of 2901250 also provides access to the slim type CD-ROM bay (**Figure 1-6**).

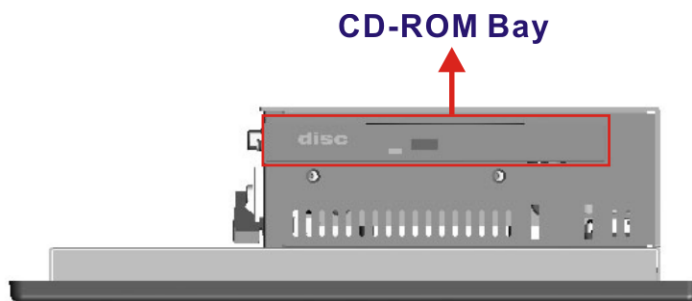

Figure 1-6: 2901250 Left View

1.2.6 Frame

An aluminum frame surrounds the TFT LCD screen. The aluminum frames of the 2901240 and 2901250 have small screw holes that are used when the flat panel PC is mounted into a rack or cabinet. These screws are circled in **Figure 1-7** and **Figure 1-8**.

2901230/2901240/2901250 Panel PC

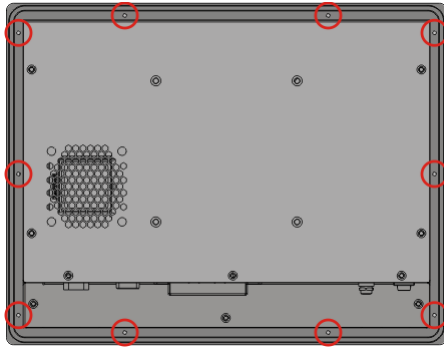

Figure 1-7: 2901240 Frame Rear View (10 panel mount retention screw holes)

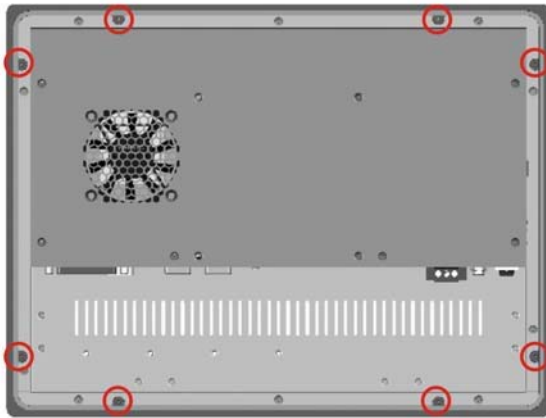

Figure 1-8: 2901250 Frame Rear View (8 panel mount retention screw holes)

1.3 Specifications

1.3.1 Preinstalled Hardware Components

The flat panel PC comes with the following components:

- „ 1 x Motherboard (preinstalled)
- „ 1 x TFT LCD screen (preinstalled)
- „ 1 x Power module (preinstalled)
- „ 1 x Power adapter

The technical specifications for these components and the system are shown in the sections below.

2901230/2901240/2901250 Panel PC

1.3.2 System Specifications

The technical specifications for the 2901230, 2901240 and 2901250 system are listed in **Table 1-4**.

SPECIFICATION	2901230	2901240	2901250
Front Panel	Aluminum Front Panel		
Chassis	Heavy-duty Steel		
LCD Panel	8.4" TFT LCD	10.4" TFT LCD	12.1" TFT LCD
Resolution	800 x 600 (SVGA)	800 x 600 (SVGA)	800 x 600 (SVGA)
Brightness	220 cd/m ² or 450 cd/m ²	230 cd/m ² or 400 cd/m ²	400 cd/m ²
Backlight MTBF	20,000 hrs	20,000 hrs	50,000 hrs
Contrast Ratio	500:1		
Touch Screen	Optional Resistive type touch screen with RS-232 interface		
Memory	Preinstalled 512MB DDR 400 SODIMM memory module		
Display	Support Dual Display		
Drive Bay	1 x 2.5" HDD bay	1 x 2.5" HDD bay	1 x slim type CD-ROM bay 1 x 2.5" HDD bay
Power	80W power adapter for socket type 60W power adapter for BGA type		
Mounting Feature	Panel, Arm, Wall, or Rack		
Color	Silver (PANTONE PMS-8001)		
Operating Temperature	0~50°C		
Relative Humidity	5 ~ 95%, non-condensing		

2901230/2901240/2901250 Panel PC

SPECIFICATION	2901230	2901240	2901250
Vibration	5 - 17Hz, 0.1" double amplitude displacement. 17 - 640Hz, 1.5G acceleration, peak to peak.		
Shock	10G Acceleration, peak to peak (11ms)		
Dimension (mm)	243.57 x 178 x 75.2	311.5 x 242 x 77.8	340 x 260 x 73.4
Net/Gross Weight	2.2/4.4 Kg	3.4/5.8 Kg	6/8 Kg

Table 1-4: System Specifications

1.3.3 Motherboard Specifications

The flat panel PC comes with a 3302150 motherboard. The technical specifications of the motherboard are listed in **Table 1-5**.

SPECIFICATION	DETAIL
CPU	Onboard Intel Celeron M 1GHz zero cache or Socket-479 base Intel Pentium M / Celeron M, FSB 400 MHz
Northbridge	852GM
Southbridge	ICH4
Memory	1 x DDR 266/200 SODIMM socket up to 1GB
BIOS	AMI BIOS Label
Display	CRT integrated in Intel 852GM LVDS Dual 18-bit TTL LCD integrated in Intel 852GM
SSD	1 x CFII
Audio	AC' 97 Codec
Ethernet	GbE (Intel 82541)
COM	4 x RS-232 ports (1 for optional touch screen)

2901230/2901240/2901250 Panel PC

USB 2.0	4 x USB 2.0 connectors
Drive Interfaces	2 x SATA drive connectors
LPT	1 x LPT connector
Extension	1x PCI-104

Table 1-5: Motherboard Specifications

1.3.4 Flat Panel Screen Specifications

1.3.4.1 2901230 Flat Panel Screen

The 2901230 comes with a 8.4" TFT LCD monitor at the front of the flat panel PC. The specifications for the LCD monitor are shown in **Table 1-6** below.

SPECIFICATION	A~D/I~L Model	E~H/M~P Model
Model	AUO-G084SN03	AUO-G084SN05
Size	8.4"	8.4"
Resolution	SVGA (800 x 600)	SVGA (800 x 600)
Active Area (mm)	170.4 x 127.8	170.4 x 127.8
Pixel Pitch (mm)	0.213 x 0.213	0.213 x 0.213
Mode	TN	TN
Number of Colors	262K	262K
Color Saturation (NTSC%)	45	45
View Angel (H/V)	130/110	120/100
Brightness (cd/m²)	220	450
Contrast Ratio	500:1	500:1
Response Time (ms) (at 25°C)	35	35
Power Consumption (W)	3.3	5.8

2901230/2901240/2901250 Panel PC

SPECIFICATION	A~D/I~L Model	E~H/M~P Model
Interface	1ch LVDS	1ch LVDS
Supply Voltage (V)	3.3	3.3
Backlight	1 CCFL	2 CCFL
Outline Dimensions (mm)	203.0 x 142.0 x 5.7	203.0 x 142.5 x 8.0
Weight (g)	215	260

Table 1-6: 8.4" TFT LCD Monitor Specifications

1.3.4.2 2901240 Flat Panel Screen

The 2901240 comes with a 10.4" TFT LCD monitor at the front of the flat panel PC.

The specifications for the LCD monitor are shown in **Table 1-7** below.

SPECIFICATION	A~D/I~L Model	E~H/M~P Model
Model	AUO-G104SN03	AUO-G104SN02
Size	10.4"	10.4"
Resolution	SVGA (800 x 600)	SVGA (800 x 600)
Active Area (mm)	211.2 x 158.4	211.2 x 158.4
Pixel Pitch (mm)	0.264	0.264
Mode	TN	TN
Number of Colors	262K	262K
Color Saturation (NTSC%)	45	45
View Angel (H/V)	120/100	120/100
Brightness (cd/m ²)	230	400
Contrast Ratio	500:1	500:1
Response Time (ms) (at 25°C)	35	35

2901230/2901240/2901250 Panel PC

SPECIFICATION	A~D/I~L Model	E~H/M~P Model
Power Consumption (W)	2.52	8.3
Interface	1ch LVDS	1ch LVDS
Supply Voltage (V)	3.3	3.3
Backlight	1 CCFL	2 CCFL
Outline Dimensions (mm)	236.0 x 174.0 x 5.6	243.0 x 184.0 x 10.6
Weight (g)	280	485

Table 1-7: 10.4" TFT LCD Monitor Specifications

1.3.4.3 2901250 Flat Panel Screen

The 2901250 comes with a 12.1" TFT LCD monitor at the front of the flat panel PC.

The specifications for the LCD monitor are shown in **Table 1-8** below.

SPECIFICATION	DETAILS
Model	AUO-G121SN01
Size	12.1"
Resolution	SVGA (800 x 600)
Active Area (mm)	246.0 x 184.5
Pixel Pitch (mm)	0.307
Mode	TN
Number of Colors	262K
Color Saturation (NTSC%)	55
View Angel (H/V)	140/110
Brightness (cd/m ²)	400
Contrast Ratio	500:1

2901230/2901240/2901250 Panel PC

Response Time (ms) (at 25°C)	35
Power Consumption (W)	7.3
Interface	1ch LVDS
Supply Voltage (V)	3.3
Backlight	2 CCFL
Outline Dimensions (mm)	279.0 x 209.0 x 11.0
Weight (g)	660

Table 1-8: 12.1" TFT LCD Monitor Specifications

1.3.5 Power Adapter Specifications

1.3.5.1 80W Power Adapter

The flat panel PC models with socket type CPU are shipped with an 80W power adapter.

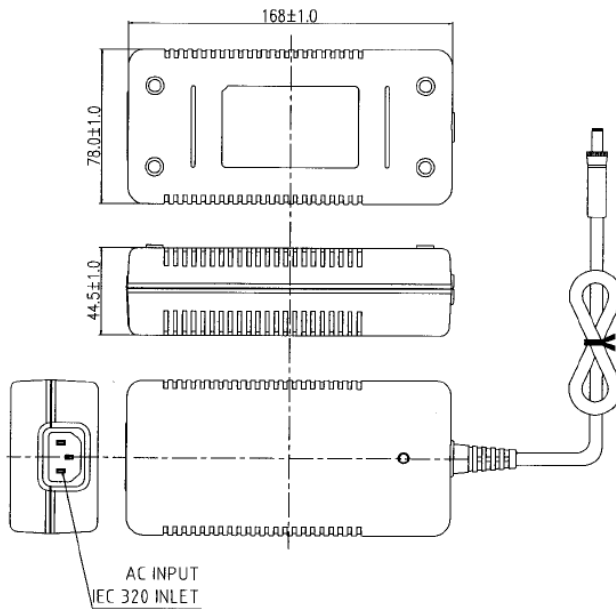

Figure 1-9: 80W Power Adapter Dimensions

The specifications for the adapter are listed in **Table 1-9**:

2901230/2901240/2901250 Panel PC

Output	Nominal	12.0V	
	Load Regulation	±5%	
	Ripple/Noise	120mV	
	Min.	0A	
	Max.	6.66A	
Protection	Short Circuit	The power supply is protected from short circuit at any outputs with no damage.	
	Over-Voltage	13.44~15.84V	
Time	Hold Up	16mS	
Input	Min.	90V	
	Nominal	100V AC ~ 240V AC	
	Max.	260V	
	Frequency	47Hz ~ 63Hz	
	Inrush Current	30A at 230VAC input	
	Leakage Current	0.75mA Max.	
	Efficiency	70%	
Environment	Temperature	Operating	0°C ~ 70°C
		Storage	-40°C ~ 85°C
	Relative Humidity	Operating (non-condensing)	10% ~ 95%
		Storage (non-condensing)	5% ~ 95%
Reliability	MTBF	100,000 hours per MIL-HDBK-217 at 25°C and 100 % of rated load.	

Table 1-9: 80W Power Adapter Specifications

1.3.5.2 60W Power Adapter

The flat panel PC models with BGA type CPU are shipped with a 60W power adapter.

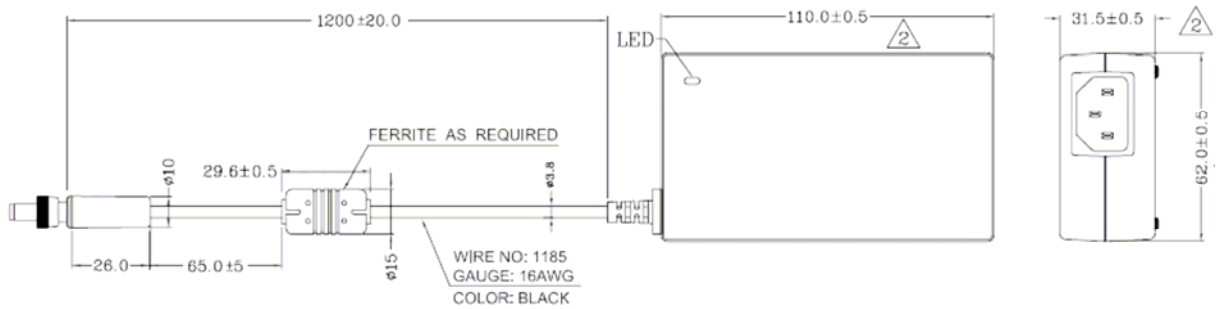

Figure 1-10: 60W Power Adapter Dimensions

The specifications for the adapter are listed in Table 1-10:

Output	Nominal	12.0V
	Regulation	11.4V to 12.6V
	Ripple/Noise	150mV
	Min.	0A
	Max.	5.0A
Protection	Short Circuit	The power supply is protected from short circuit at any outputs with no damage.
	Over-Voltage	11.4Vdc~12.6Vdc
Time	Hold Up	8mS minimum
Input	Min.	90V
	Nominal	115V AC ~ 230V AC
	Max.	264V

2901230/2901240/2901250 Panel PC

	Frequency	47Hz ~ 63Hz	
	Inrush Current	100A for 220V	
	Input Line Current	1.5A Max. for 115V; 1.0A Max. for 230V	
	Efficiency	80%	
Environment	Temperature	Operating	0°C ~ 40°C
		Storage	-20°C ~ 65°C
	Relative Humidity	Operating (non-condensing)	20% ~ 80%
		Storage (non-condensing)	10% ~ 90%
	Shock	Storage: 40 G maximum, 1/2 sine wave, 6 msec on any axis.	
		Operating: 10 G maximum, 1/2 sine wave, 6 msec on any axis.	
Reliability	MTBF	60,000 hours per MIL-HDBK-217 at 25°C and 100 % of rated load.	

Table 1-10: 60W Power Adapter Specifications

1.3.6 Power Module Specifications

The 9VDC~36VDC models of the 2901230/2901240/2901250 flat panel PC support a 9V~36V DC input. The input support depends on the 9V~36V DC input power module installed in the system. The specifications for the 9V~36V DC are shown in **Table 1-11**.

Model Name:	9V~36V DC
Input	9VDC~36VDC
Output:	

2901230/2901240/2901250 Panel PC

12V	5A (Max.)
Max. Total Output:	60W
Performance Characteristics:	
Noise & Ripple:	< 300mV
Line Regulation:	< 200mV
Load Regulation	<85mV
Efficiency:	Min. 80%
Dimensions:	82mm x 25mm
Weight:	28g
Operating Temperature:	--40°C~85°C

Table 1-11: DC-to-DC Power Module Specifications

1.4 Dimensions

1.4.1 2901230 Dimensions

The dimensions of the 2901230 flat panel PC are shown in **Figure 1-11** below.

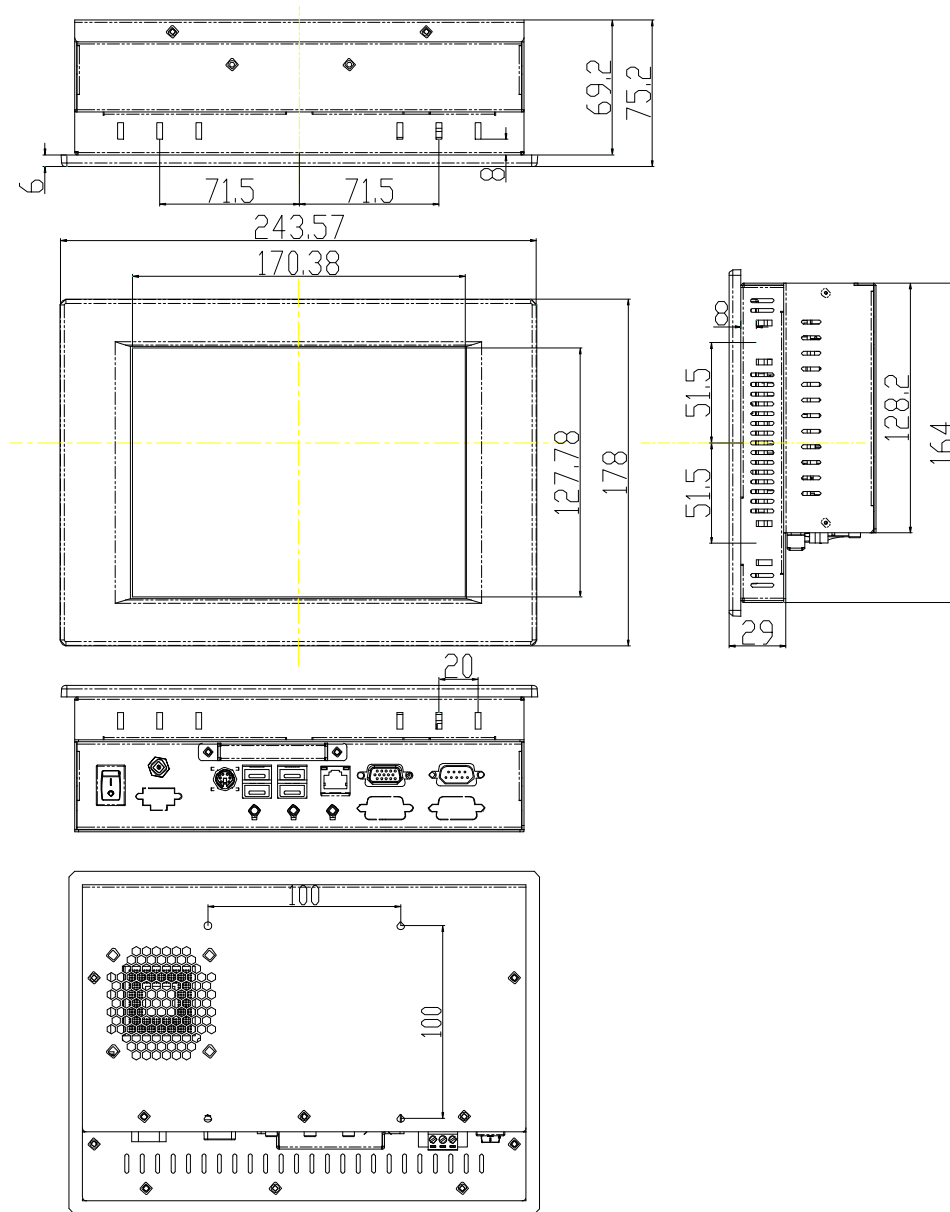

Figure 1-11: 2901230 Dimensions (units in mm)

2901230/2901240/2901250 Panel PC

1.4.2 2901240 Dimensions

The dimensions of the 2901240 flat panel PC are shown in **Figure 1-12** below.

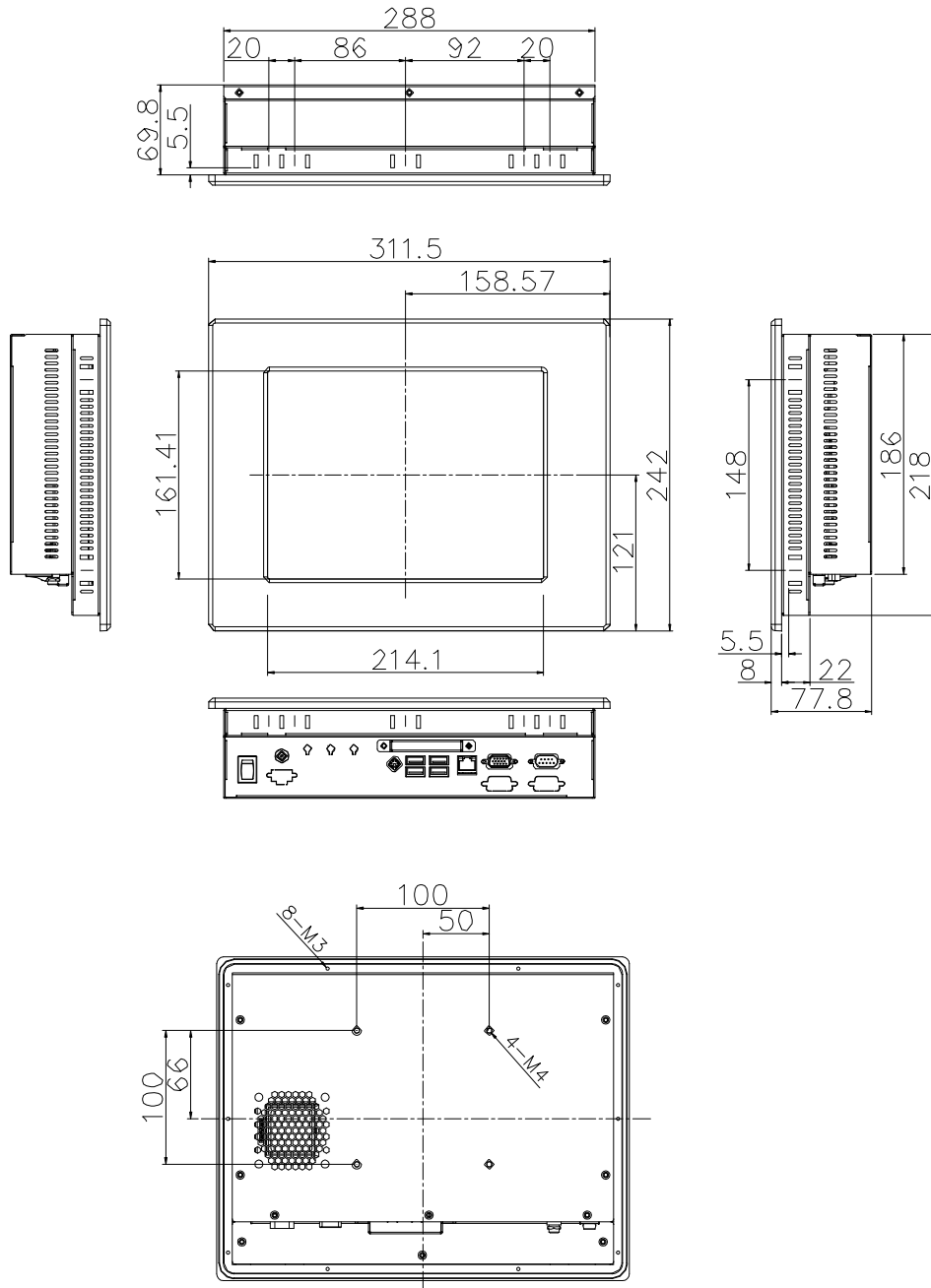

Figure 1-12: 2901240 Dimensions (units in mm)

1.4.3 2901250 Dimensions

The dimensions of the 2901250 flat panel PC are shown in **Figure 1-13** below.

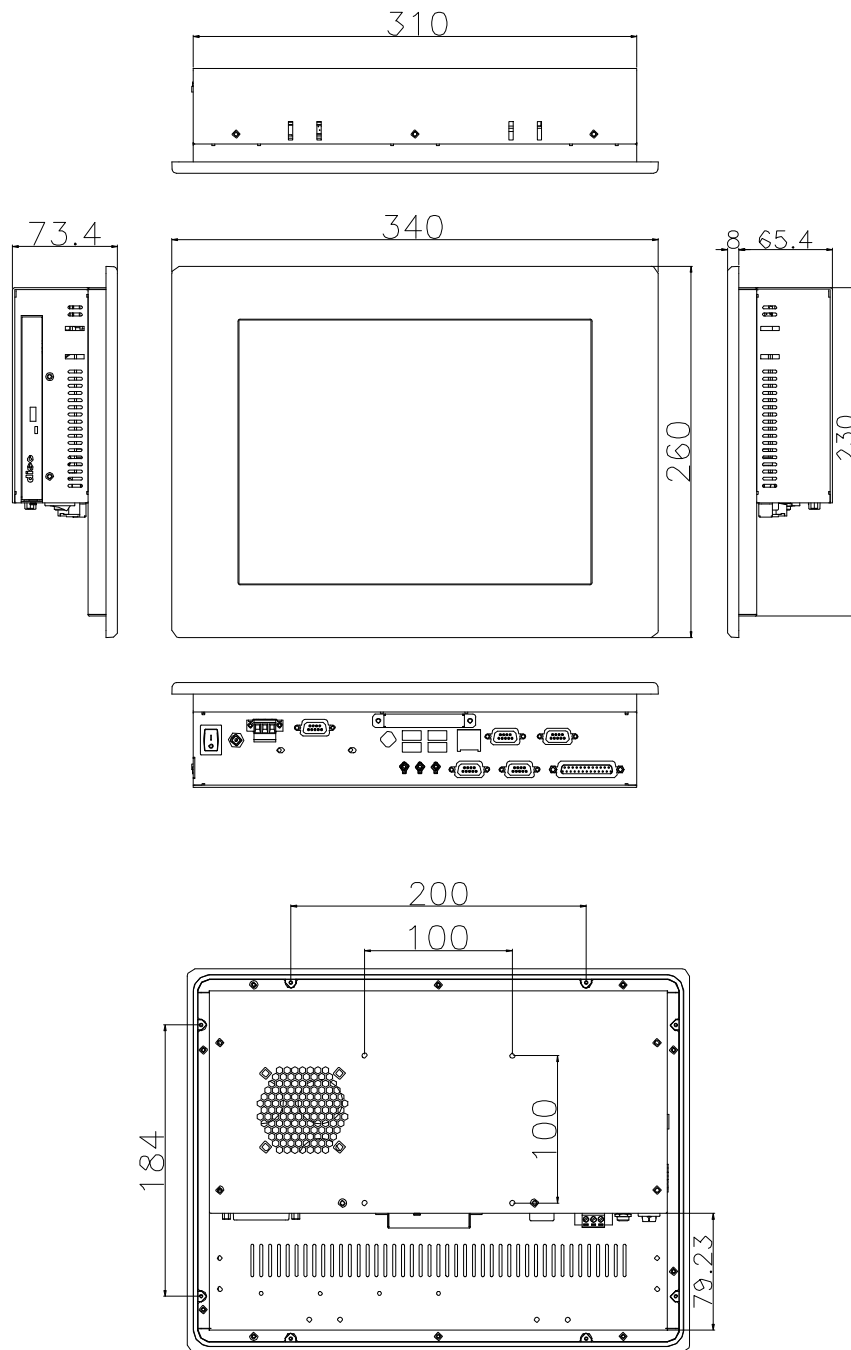

Figure 1-13: 2901250 Dimensions (units in mm)

3302150

Motherboard

2.1 Introduction

The 2901230, 2901240 and 2901250 flat panel PC all contain a 3302150 motherboard. The motherboard is the heart of any computer and is responsible for transmitting, receiving and processing data as well as driving the different onboard devices. This chapter gives a brief introduction to the 3302150 motherboard. For more complete details on the connectors and the different implementations of the 3302150, please refer to the 3302150 user guide.

2.2 CPU Support

The 3302150 installed in the flat panel PC supports socket 479, Intel Pentium M / Celeron M FSB 400 MHz CPU or onboard Intel Celeron M 1GHz zero cache CPU.

2.3 Onboard Chipsets

2.3.1 Northbridge and Southbridge Chipsets

The following chipsets are preinstalled on the board:

- „ **Northbridge:** Intel 852GM
- „ **Southbridge:** ICH4

The following two sections (**Section 2.3.2** and **Section 2.3.3**) list some of the features of the 852GM and the ICH4 chipsets. For more information on these two chipsets please refer to the Intel website.

2.3.2 852GM Northbridge Chipset

The 852GM northbridge chipset comes with the following features:

- „ Supports Intel® NetBurst® micro-architecture
- „ 400 MHz system bus delivers a high-bandwidth connection between the processor and the platform
- „ Supports integrated graphics utilizing Intel® Extreme Graphics 2 technology
- „ Three USB host controllers provide high performance peripherals with 480 Mbps of bandwidth, while enabling support for up to six USB 2.0 ports.

2901230/2901240/2901250 Panel PC

- „ The latest AC '97 implementation delivers 20-bit audio for enhanced sound quality and full surround-sound capability.
- „ LAN Connect Interface (LCI) provides flexible network solutions such as 10/100 Mbps Ethernet and 10/100 Mbps Ethernet with LAN manageability
- „ Dual Ultra ATA/100 controllers, coupled with the Intel® Application Accelerator supports faster IDE transfers to storage devices
- „ Intel Application Accelerator software provides additional performance over native ATA drivers by improving I/O transfer rates and enabling faster O/S load time, resulting in accelerated boot times

2.3.3 ICH4 Southbridge Chipset

The ICH4 southbridge chipset comes with the following features:

- „ PCI Local Bus Specification, Revision 2.2-compliant with support for 33 MHz PCI operations.
- „ ACPI Power Management Logic Support
- „ Enhanced DMA controller, Interrupt controller, and timer functions
- „ Integrated IDE controller supports Ultra ATA100/66/33
- „ USB host interface with support for 6 USB ports; 3 UHCI host controllers; 1 EHCI high-speed
- „ USB 2.0 Host controller
- „ Integrated LAN controller
- „ System Management Bus (SMBus) Specification, Version 2.0 with additional support for I2C devices
- „ Supports Audio Codec '97, Revision 2.3 specification
- „ Low Pin Count (LPC) interface
- „ Firmware Hub (FWH) interface support
- „ Alert On LAN* (AOL) and Alert On LAN 2* (AOL2)

2.4 Graphics Support

The Intel® Extreme Graphics 2 is integrated on the Intel® 852GM Northbridge chipset. The Intel® Extreme Graphics 2 features are listed below.

- „ **Enhanced Rapid Pixel and Texel Rendering:** Optimized visual quality and performance from the addition of hardware to support of texel formatting, bicubic filter, color blending accuracy, and video mixing render, resulting in optimized visual quality and performance.
- „ **Zone Rendering 2 Technology:** Enhances the performance of zone rendering by using larger zones and new commands that improve graphics pipeline efficiency.
- „ **Dynamic Video Memory Technology v2.0:** Increases total system performance by optimizing the efficiency of AGP dynamic video memory by increasing its size of Video RAM allocation to 96 MB.
- „ **Enhanced Intelligent Memory Management:** Improves memory bandwidth efficiency and platform performance by improving the memory management arbitration between CPU, system memory and graphics memory.

Intel® Extreme Graphics 2 specifications are listed below:

- „ Enhanced 2D:
 - 256-bit internal path
 - 8/16/32bpp
 - DirectDraw*, GDI, GDI+
 - Anti-aliased text support
 - Alpha blending
 - Alphas stretch blitter
 - Hardware alpha blended RGB cursor
 - Color space conversion
 - 5x2 overlay support
 - Rotate, scale and translate operations
- „ High-performance 3D:
 - 256-bit internal path
 - 32bpp/ 24ZorW/ 8 Stencil

2901230/2901240/2901250 Panel PC

- DX7*/DX8*/OGL*1.1
- DXTn texture compression
- Up to 4 textures / pixel on a single pass
- Cubic reflection map
- Embossed/DOT3 bump mapping
- Multi-texture
- DOT3 bump-mapping
- Point sprites
- „ Video and Display:
 - DirectShow*/DirectVA*
 - Hardware motion compensation support for DVD playback
 - 4x2 overlay filter
 - 350 MHz DAC frequency
 - Maximum DVO pixel rate of up to 330MP/s
 - Flat panel monitors and TV-out support via AGP Digital Display (ADD) cards
 - 350 MHz DAC for 1800x1440 @ 85Hz max CRT resolution or 2048x1536@60Hz max FP resolution
 - Synchronous display for dual monitor capabilities
 - 350MHz RAMDAC for up to QXGA analog monitor support
 - Dual DVO ports for up to QXGA digital display support
 - Multiple display types (LVDS, DVI, TV-out, CRT)

2.5 Peripheral Device Interfaces, Connectors, and Slots

The peripheral device connectors, interfaces and slots on the 3302150 motherboard are listed in the sections below.

2.5.1 OEM Options

Many of the peripheral device connectors listed below are not connected to any devices. These connectors are reserved for OEM customizations. For a customized option, please contact the vendor, reseller or Global American, Inc. sales representative.

2.5.2 Internal Slots

The slots listed below can all be found on the 3302150 motherboard.

- „ 1 x 200-pin DDR SODIMM socket
- „ 1 x CFII slot

2.5.3 Internal Peripheral Device Connectors

The peripheral device connectors listed below are located on the 3302150 motherboard. Pinouts for these connectors can be found in **Appendix A**.

- „ 1 x 12V power connector
- „ 1 x 4-bit GPIO connector
- „ 1 x ATX power button connector
- „ 1 x ATX power connector
- „ 1 x Audio connector
- „ 1 x Battery connector
- „ 1 x DIO connector
- „ 1 x Fan connector
- „ 1 x IDE device connector
- „ 1 x Keyboard/mouse connector
- „ 1 x LED connector
- „ 1 x LCD LVDS interface connector
- „ 1 x Parallel port connector
- „ 1 x Reset connector
- „ 2 x Serial ATA connectors
- „ 3 x Serial port connectors
- „ 2 x USB 2.0 connectors

2.5.4 External Peripheral Device Connectors

The peripheral device connectors listed below are located on the rear panel of the 3302150 motherboard. Pinouts for these connectors can be found in **Appendix A**.

- „ 1 x Serial port connector (COM)
- „ 1 x VGA connector

2901230/2901240/2901250 Panel PC

- „ 1 x RJ-45 Ethernet connector
- „ 4 x USB 2.0 ports
- „ 1 x Keyboard/Mouse connector

THIS PAGE IS INTENTIONALLY LEFT BLANK

Installation and Configuration

3.1 Installation Precautions

When installing the flat panel PC, please follow the precautions listed below:

- „ **Power turned off:** When installing the flat panel PC make sure the power is off. Failing to turn off the power may cause severe injury to the body and/or damage to the system.
- „ **Certified Engineers:** Only certified engineers should install and modify onboard functionalities.
- „ **Mounting:** The flat panel PC is a heavy device. When mounting the system onto a rack, panel, wall or arm please make sure that at least two people are assisting with the procedure.
- „ **Anti-static Discharge:** If a user open the rear panel of the flat panel PC, to configure the jumpers or plug in added peripheral devices, ground themselves first and wear an anti-static wristband.

3.2 Preinstalled Components

The following components are all preinstalled.

- „ Motherboard
- „ TFT LCD screen
- „ 512MB DDR400 SODIMM memory
- „ Power switch

Preinstalled OEM customizations may include the following.

- „ 2.5" HDD
- „ Resistive type touch screen
- „ Power module
- „ CD drive (2901250 Only)

Installation of some of the components are described in **the following sections**.

3.3 Installation and Configuration Steps

The following installation steps must be followed.

2901230/2901240/2901250 Panel PC

- Step 1:** Unpack the flat panel PC
- Step 2:** Set the jumper settings
- Step 3:** Install CPU and CPU cooler
- Step 4:** Install HDD and CD drive
- Step 5:** Mount the flat panel PC
- Step 6:** Connect peripheral devices to the bottom panel of the flat panel PC
- Step 7:** Configure the system

3.4 Unpacking

To unpack the flat panel PC, follow the steps below:



WARNING!

The front side LCD screen has a protective plastic cover stuck to the screen. Only remove the plastic cover after the flat panel PC has been properly installed. This ensures the screen is protected during the installation process.

-
- Step 1:** Use box cutters, a knife or a sharp pair of scissors that seals the top side of the external (second) box.
 - Step 2:** Open the external (second) box.
 - Step 3:** Use box cutters, a knife or a sharp pair of scissors that seals the top side of the internal (first) box.
 - Step 4:** Lift the monitor out of the boxes.
 - Step 5:** Remove both polystyrene ends, one from each side.
 - Step 6:** Pull the plastic cover off the flat panel PC.
 - Step 7:** Make sure all the components listed in the packing list are present.

3.4.1 Packing List

The flat panel PC is shipped with the following components:

- „ 1 x HDD IDE cable
- „ 1 x Jumper pack
- „ 1 x Panel mounting kit
- „ 1 x Power cord
- „ 1 x PS2 keyboard/mouse Y-cable
- „ 1 x Screw kit
- „ 1 x User manual and driver CD
- „ 1 x Wall mounting kit
- „ 1 x Slim CD-ROM installation kit (2901250 Only)
- „ 1 x 80W power adapter for socket type
- „ 1 x 60W power adapter for BGA type
- „ 1 x Touch screen driver CD (touch screen models only)
- „ 1 x Touch pen (touch screen models only)

If any of these items are missing or damaged, contact the distributor or sales representatives immediately.

3.5 Jumper Settings



NOTE:

These jumper settings and the jumper locations are described in detail in the User Manual that came with the 3302150 motherboard. Please refer to this manual for a more detailed understanding of the jumper settings



NOTE:

A jumper is a metal bridge that is used to close an electrical circuit. It consists of two metal pins and a small metal clip (often protected by a plastic cover) that slides over the pins to connect them. To CLOSE/SHORT a jumper means connecting the pins of the jumper with the plastic clip and to OPEN a jumper means removing the plastic clip from a jumper.

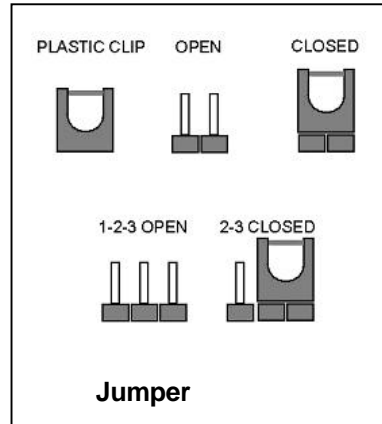

The 3302150 comes with four jumpers. They are listed below.

- „ CF card setup (JP1)
- „ Clear CMOS (JP4)
- „ COM2 RS232/RS422/RS485 selector (JP2)
- „ LCD Voltage selector (JP6)

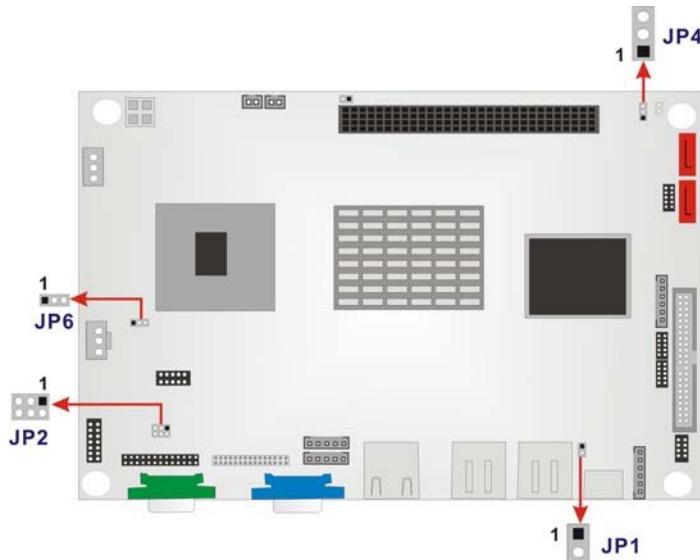

Figure 3-1: Jumper Locations

3.5.1 Remove the Back Cover

3.5.1.1 2901230 Back Cover Removal

The back cover of the 2901230 is secured to the chassis with seven retention screws, five on the rear panel and two on the top panel (**Figure 3-2**). Remove the seven retention screws and lift the cover off the 2901230.

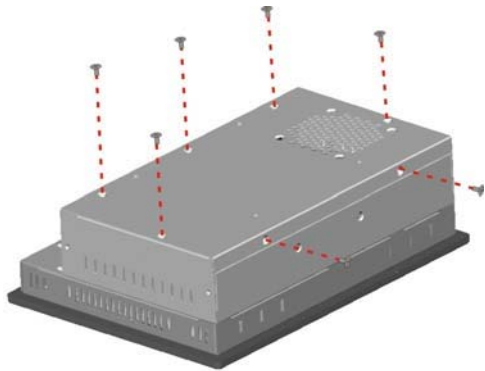

Figure 3-2: 2901230 Back Cover Retention Screws

3.5.1.2 2901240 Back Cover Removal

The back cover of the 2901240 is secured to the chassis with ten retention screws, seven on the rear panel and three on the top panel (**Figure 3-3**). Remove the ten retention screws and lift the cover off the 2901240.

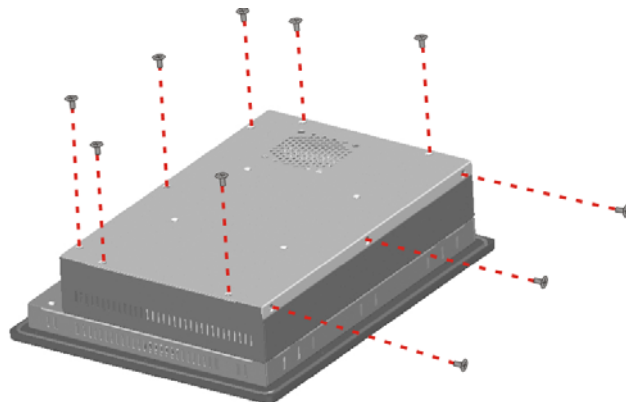

Figure 3-3: 2901240 Back Cover Retention Screws

2901230/2901240/2901250 Panel PC

3.5.1.3 2901250 Back Cover Removal

The back cover is secured to the chassis with nine retention screws, six on the rear panel and three on the top panel (**Figure 3-4**). Remove the nine retention screws and lift the cover off the 2901250.

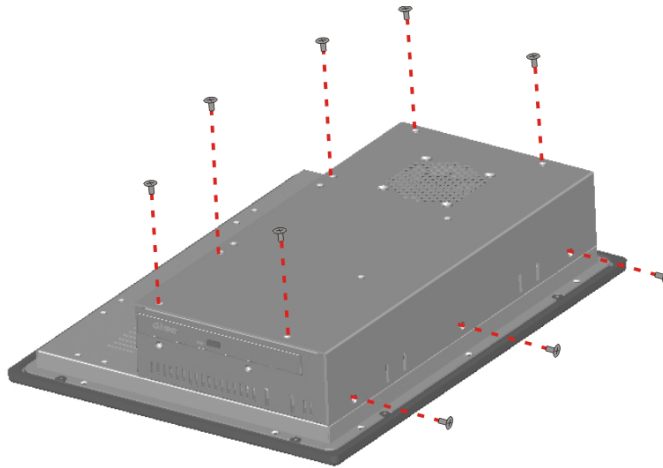

Figure 3-4: 2901250 Back Cover Retention Screws

3.5.2 JP1: CF Card Setup

The CF Card Setup jumper configures a CF card as either the slave or the master.

JP1	DESCRIPTION
Open	Slave (Default)
Close	Master

Table 3-1: CF Card Setup Jumper Settings

3.5.3 JP4: Clear CMOS Setup

If the motherboard fails to boot due to improper BIOS settings, use this jumper to clear the CMOS data and reset the system BIOS information. To do this, use the jumper cap to close pins 2 and 3 for a few seconds then reinstall the jumper clip back to pins 1 and 2.

2901230/2901240/2901250 Panel PC

If the “CMOS Settings Wrong” message displays during the boot up process, try to correct the fault by pressing the F1 to enter the CMOS Setup menu. Then do one of the following:

- „ Enter the correct CMOS setting
- „ Load Optimal Defaults
- „ Load Failsafe Defaults.

After one of the above has been done, save the changes and exit the CMOS Setup menu.

JP4	DESCRIPTION
1 - 2	Normal (Default)
2 - 3	Clear CMOS

Table 3-2: Clear CMOS Jumper Settings

3.5.4 JP6: LCD Voltage Setup



WARNING!

Do not change this voltage. This voltage has been preset and is compatible with the currently installed TFT LCD screen. Change this jumper setting may cause damage to the system.

The LCD Voltage Setup jumper sets the voltage for the LCD screen. This setting **MUST** NOT be changed.

JP6	DESCRIPTION
1-2	LCDVCC = +3.3V (default)
2-3	LCDVCC = +5V

Table 3-3: LCD Voltage Setup Jumper Settings

3.5.5 JP2: COM Port Jumper Setting

The COM Port jumper configures the COM2 serial port.

2901230/2901240/2901250 Panel PC

JP2	DESCRIPTION
1-2 closed	RS232 (default)
3-4 closed	RS422
5-6 closed	RS485

Table 3-4: JP2 Jumper Settings

3.6 CPU and CPU Cooler Installation

3.6.1 CPU Installation



WARNING!

CPUs are expensive and sensitive components. When installing the CPU, please be careful not to damage it in anyway. Make sure to install it properly and ensure that a heat sink and CPU cooling fan is properly installed before running the CPU card or else both the CPU and the board will be damaged.

To install an Intel 479-pin CPU onto the motherboard, follow the steps below:

Step 1: Unlock the CPU retention screw. When shipped, the retention screw of the CPU socket should be in the unlocked position. If it is not in the unlocked position, use a screwdriver to reposition the screw in an unlocked position. (See **Figure 3-5**)

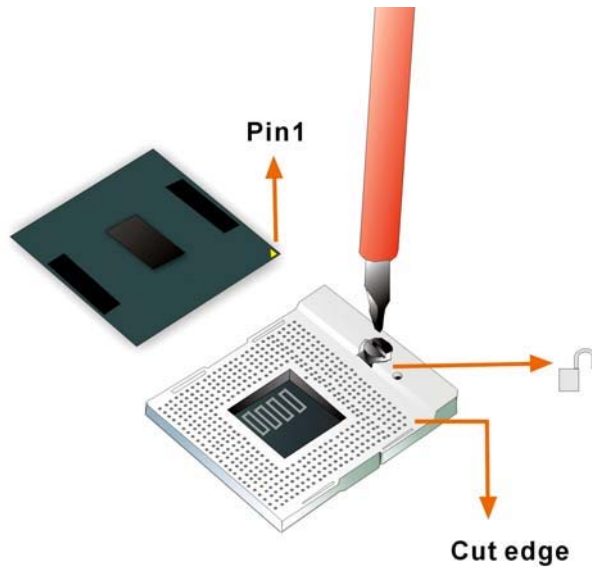

Figure 3-5: Make sure the CPU socket retention screw is unlocked

- Step 2: Inspect the CPU socket** Make sure there are no bent pins and make sure the socket contacts are free of foreign material. If any debris is found, remove it with compressed air.
- Step 3: Orientate the CPU properly.** Make sure the IHS (Integrated Heat Sink) side is facing upward.
- Step 4: Correctly position the CPU.** Match the Pin 1 mark with the cut edge on the CPU socket.
- Step 5: Align the CPU pins.** Carefully align the CPU pins with the holes in the CPU socket.
- Step 6: Insert the CPU.** Gently insert the CPU into the socket. If the CPU pins are properly aligned, the CPU should slide into the CPU socket smoothly
- Step 7: Lock the retention screw.** Rotate the retention screw into the locked position.
(See Figure 3-6)

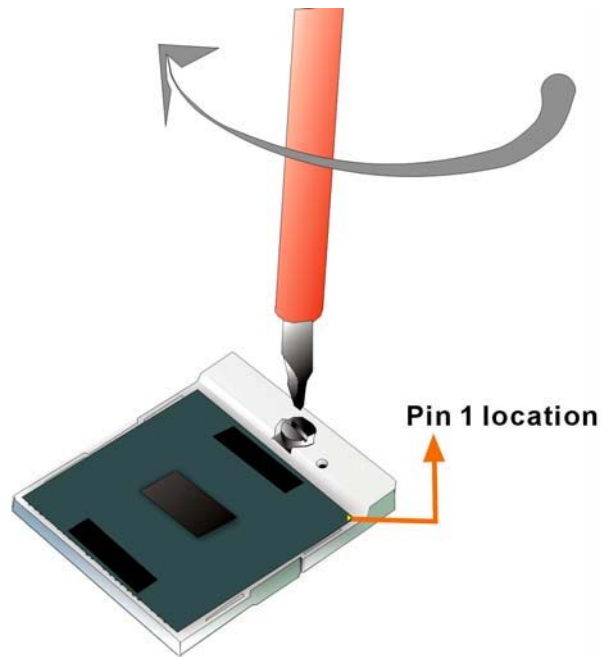

Figure 3-6: Lock the CPU Socket Retention Screw

3.6.2 Cooling Kit Installation



Figure 3-7: Cooling Kit

Global American, Inc. provides a cooling kit designed for socket 479 CPUs. (See **Figure 3-7**) The cooling kit is comprised of a CPU heat sink and a cooling fan.



NOTE:

The heatsink comes with a sprayed layer of thermal paste. Make sure not to accidentally wipe away the thermal paste while unpacking or installing the heatsink. Thermal paste between the CPU and the heatsink is important for optimum heat dissipation.

To install the cooling kit, please follow the steps below.

- Step 1: Place the cooling kit onto the CPU.** Make sure that the CPU cable can be properly routed when the cooling kit is installed.
- Step 2: Properly align the cooling kit.** Make sure its four threaded screw fasteners can pass through the pre-drilled holes on PCB.
- Step 3: Secure the cooling kit.** From the solder side of the PCB, align the provided nut caps to the heatsink screw threads that protrude through the PCB holes. Without over tightening the nut caps, insert them onto the protruding screw threads to secure the cooling kit to the PCB board. (See **Figure 3-8**)

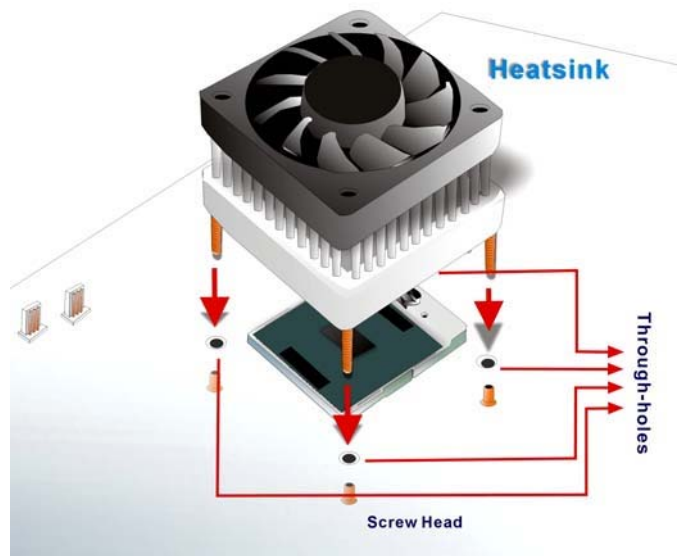

Figure 3-8: Securing the Cooling Kit

- Step 4: Connect the fan cable.** Connect the cooling kit fan cable to the FAN1 connector

2901230/2901240/2901250 Panel PC

on the motherboard. Carefully route the cable and avoid heat generating chips and fan blades. (See **Figure 3-9**)

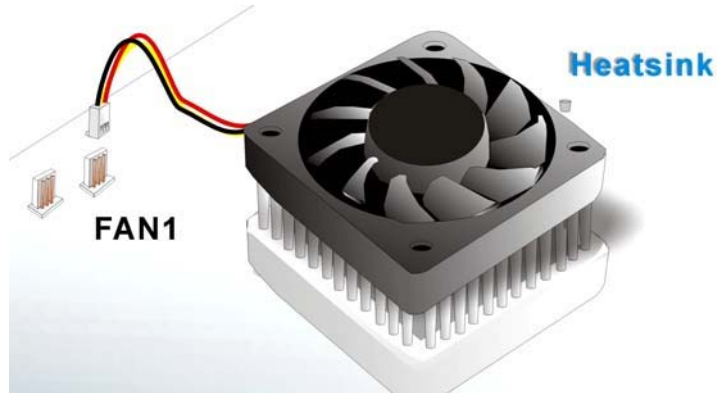

Figure 3-9: Connect the cooling fan cable



NOTE:

A 512MB SODIMM memory module is already preinstalled on the solder side of the motherboard. After installing the CPU and CPU cooler (if necessary), the panel PC shall be able to run properly.

3.7 HDD Installation

3.7.1 2901230 HDD Installation

To install the HDD into the 2901230, please follow the steps below:

- Step 1:** Remove the back cover. See **Section 0** above.
- Step 2:** Remove the HDD bracket from the 2901230. The HDD bracket is attached on the 2901230 with four retention screws, two on the top panel (**Figure 3-10**) and two inside the chassis (**Figure 3-11**). Remove the four retention screws and lift the bracket off the panel PC.

2901230/2901240/2901250 Panel PC



Figure 3-10: 2901230 HDD Bracket Retention Screws (Top Panel)



Figure 3-11: 2901230 HDD Bracket Retention Screws (Inside)

Step 3: Attach the HDD bracket to the HDD. To do this, align the four retention screw holes in the HDD bracket with the retention screw holes on the bottom of the HDD. Insert four retention screws into the HDD bracket. (**Figure 3-12**).

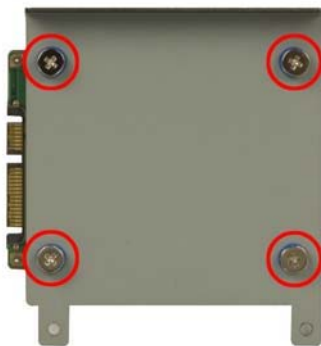

Figure 3-12: 2901230 HDD Retention Screws

Step 4: Install the HDD into the 2901230 by aligning the retention screw holes in the

2901230/2901240/2901250 Panel PC

HDD bracket with the retention screw holes on the panel PC. Insert the four retention screws.



CAUTION!

When inserting the bottom left retention screw back to the 2901230, please reattach the grounding cable to the retention screw.

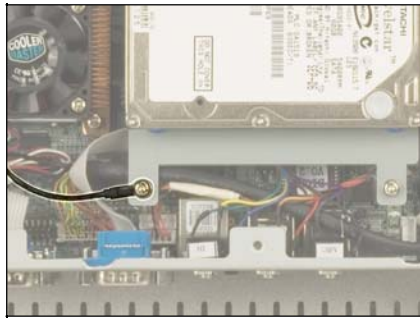

Step 5: Connect the IDE/SATA cable from the IDE/SATA connector on the motherboard to the rear of HDD.

3.7.2 2901240 HDD Installation

To install the HDD into the 2901240, please follow the steps below:

Step 1: Remove the back cover. See **Section 0** above.

Step 2: Remove the HDD bracket from the 2901240. The HDD bracket is attached on the 2901240 with four retention screws inside the chassis (**Figure 3-13**).

Remove the four retention screws and lift the bracket off the panel PC.



Figure 3-13: 2901240 HDD Bracket Retention Screws

Step 3: Attach the HDD bracket to the HDD. To do this, align the four retention screw holes in the HDD bracket with the retention screw holes on the bottom of the HDD. Insert four retention screws into the HDD bracket. (**Figure 3-14**).



Figure 3-14: 2901240 HDD Retention Screws

Step 4: Install the HDD into the 2901240 by aligning the retention screw holes in the HDD bracket with the retention screw holes on the panel PC. Insert the four retention screws.

2901230/2901240/2901250 Panel PC

Step 5: Connect the IDE/SATA cable from the IDE/SATA connector on the motherboard to the rear of HDD.

3.7.3 2901250 HDD Installation

To install the HDD, please follow the steps below:

Step 1: Remove the back cover. See **Section 0** above.

Step 2: Attach the HDD brackets to the HDD. To do this, align the two retention screw holes in each HDD bracket with the retention screw holes on the side of the HDD. Insert two retention screws into both brackets on both sides of the HDD (**Figure 3-15**).

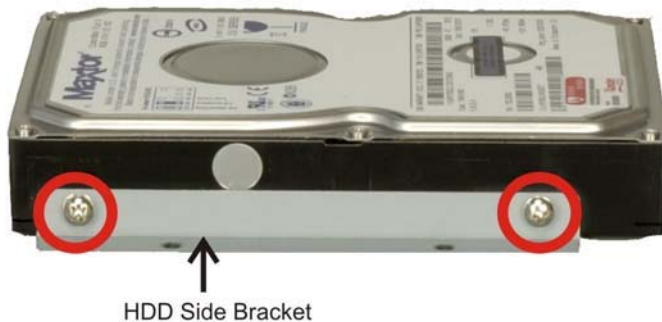

Figure 3-15: 2901250 HDD Bracket Retention Screws

Step 3: Install the HDD into the 2901250 by aligning the retention screw holes in the base of the HDD brackets with the retention screw holes on the metal sheet. Insert the four retention screws, two into the base of each HDD bracket (**Figure 3-16**.)



Figure 3-16: 2901250 HDD Retention Screws

Step 4: Connect the IDE/SATA cable from the IDE/SATA connector on the motherboard to the rear of HDD.

3.8 CD Drive Installation (2901250 Only)

To install the CD drive into the 2901250, please follow the steps below:

Step 1: Attach the CD drive adapter to the CD drive by aligning the two retention screw holes in the CD drive adapter with the retention screw holes on the rear side of the CD drive. Place the two spacers between the CD drive and CD drive adapter. Insert two retention screws into the adapter (**Figure 3-17**).

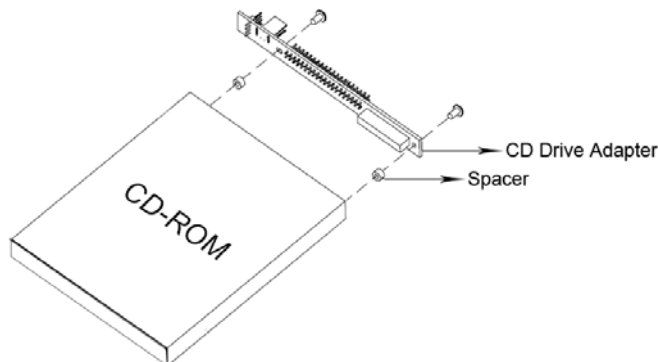

Figure 3-17: CD Drive Adapter Installation

Step 2: Attach the CD drive bracket to the CD drive. To do this, align the four retention

2901230/2901240/2901250 Panel PC

screw holes in the CD drive bracket with the retention screw holes on the side of the CD drive. Insert four retention screws into the bracket on both sides of the HDD (**Figure 3-18**).



Figure 3-18: CD Drive Bracket Retention Screws

Step 3: Remove the back cover. See **Section 0** above.

Step 4: Install the CD drive into the 2901250 by aligning the retention screw holes in the sides of the CD drive bracket with the retention screw holes on the left panel, the bottom panel and inside the chassis (**Figure 3-19**). Insert the five retention screws.

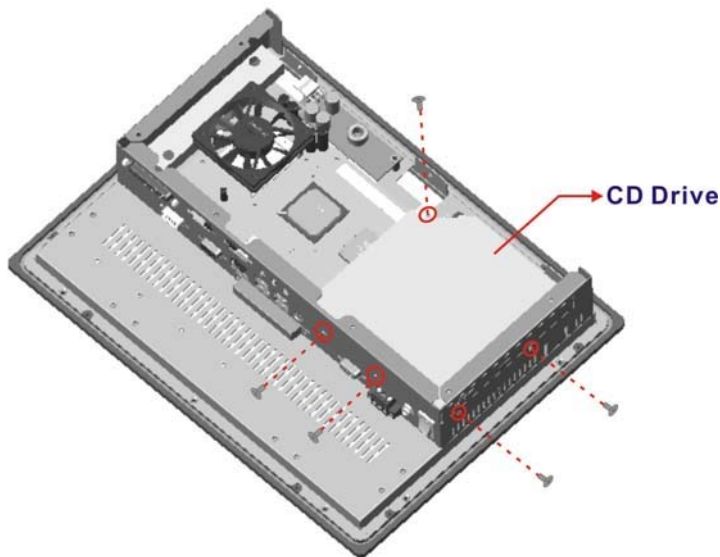

Figure 3-19: 2901250 CD Drive Retention Screws

Step 5: Connect the IDE ribbon cable and power cable from the connectors on the motherboard to the rear of the CD drive.

3.9 Mounting the System



WARNING!

When mounting the flat panel PC onto an arm, onto the wall or onto a panel, it is better to have more than one person to help with the installation to make sure the flat panel PC does not fall down and get damaged.

The four methods of mounting the flat panel PC are listed below.

- „ Wall mounting
- „ Panel mounting
- „ Arm mounting
- „ Rack mounting

The four mounting methods are described below.

3.9.1 Wall Mounting

To mount the 2901230/2901240/2901250 flat panel PC onto a wall, please follow the steps below.

- Step 1:** Select the location on the wall for the wall-mounting bracket.
- Step 2:** Carefully mark the locations of the four bracket screw holes on the wall.
- Step 3:** Drill four pilot holes at the marked locations on the wall for the bracket retention screws.
- Step 4:** Align the wall-mounting bracket screw holes with the pilot holes.
- Step 5:** Secure the mounting-bracket to the wall by inserting the retention screws into the four pilot holes and tightening them (**Figure 3-20**).

2901230/2901240/2901250 Panel PC

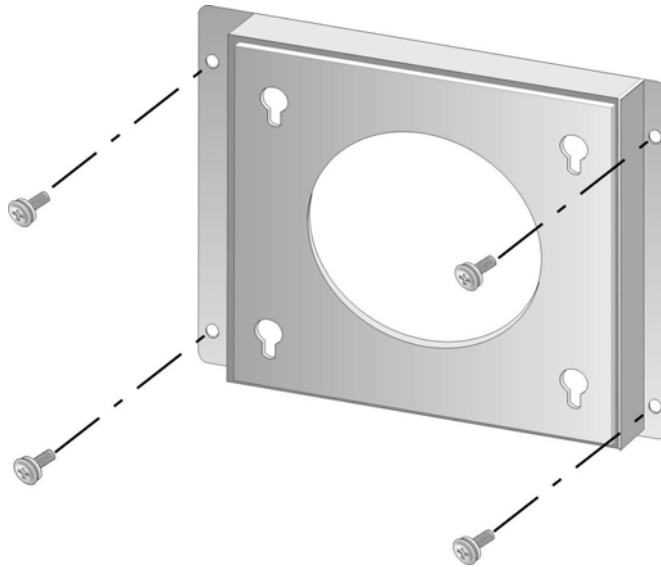

Figure 3-20: Wall-mounting Bracket

- Step 6:** Insert the four monitor mounting screws provided in the wall mounting kit into the four screw holes on the rear panel of the monitor and tighten until the screw shank is secured against the rear panel (**Figure 3-21**).
- Step 1:** Align the mounting screws on the monitor rear panel with the mounting holes on the bracket.
- Step 2:** Carefully insert the screws through the holes and gently pull the monitor downwards until the monitor rests securely in the slotted holes (**Figure 3-21**). Ensure that all four of the mounting screws fit snugly into their respective slotted holes.



NOTE:

In the diagram below the bracket is already installed on the wall.

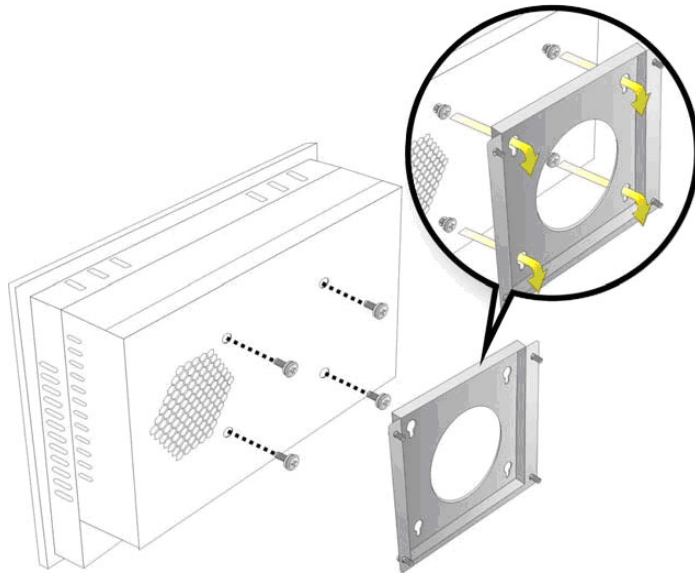

Figure 3-21: Mount the Chassis

Step 3: Secure the panel PC with the wall-mounting kit. To do this, stick the protective cushion to the wall-mounting kit first. Then, put the wall-mounting kit on the top panel of the panel PC. Carefully mark the location of the wall-mounting kit screw holes on the wall. Drill a pilot hole at the marked location on the wall. Secure the wall-mounting kit to the wall by inserting a retention screw into the pilot hole on the wall (**Figure 3-22**). This step is to avoid the panel PC being pushed apart from the wall-mounting bracket accidentally.

2901230/2901240/2901250 Panel PC

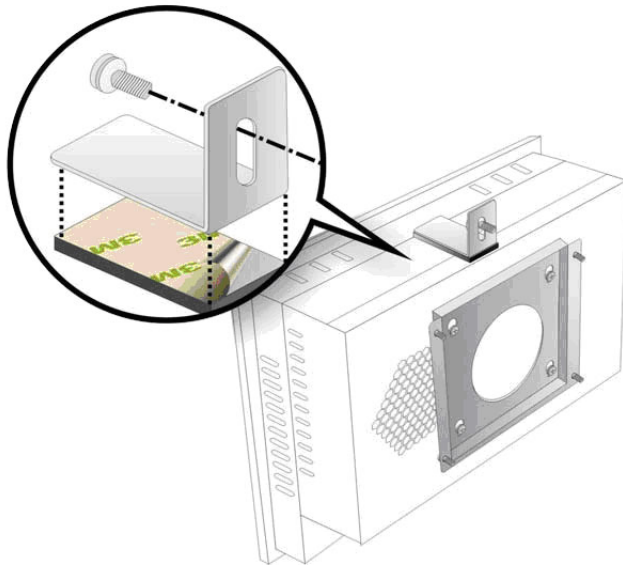

Figure 3-22: Secure the Chassis

3.9.2 Panel Mounting

3.9.2.1 2901230/2901240 Panel Mounting

To mount the 2901230/2901240 flat panel PC into a panel, please follow the steps below.

- Step 1:** Select the position in the panel to mount the 2901230/2901240.
- Step 2:** Cut out a section from the panel that corresponds to the dimensions of the 2901230/2901240 flat panel PC chassis. The panel section that is cut out must be smaller than the size of the aluminum frame that surrounds the TFT LCD panel but just large enough for the chassis to fit through. Refer to **Figure 3-23** and **Figure 3-24** for the suggested cut out size.

2901230/2901240/2901250 Panel PC

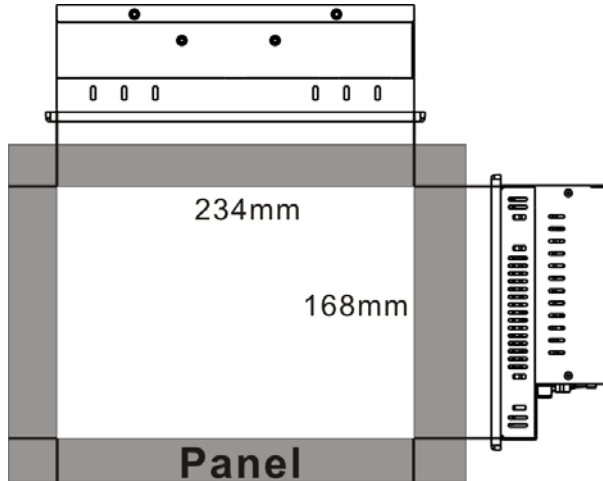

Figure 3-23: Suggested Panel Cut Out Size for 2901230

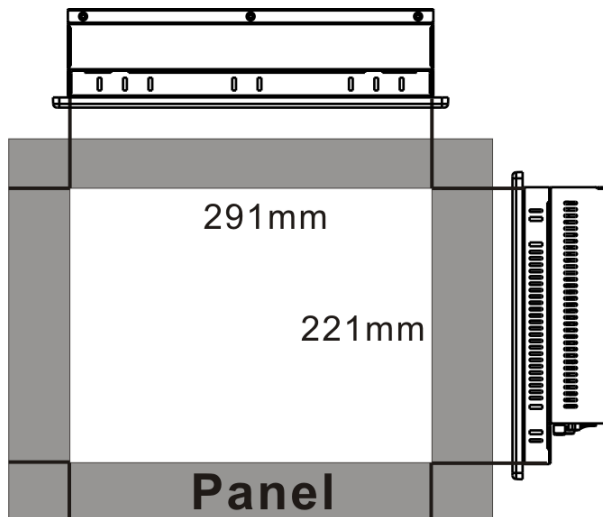

Figure 3-24: Suggested Panel Cut Out Size for 2901240

- Step 3:** Slide the 2901230/2901240 flat panel computer through the previously cut hole. The chassis at the rear of the 2901230/2901240 flat panel should slide easily through the hole. Only stop sliding the panel through the hole when the back of the front aluminum frame is flush against the panel.
- Step 4:** Insert the panel mounting clamps into the pre-formed holes along the edges of the chassis, behind the aluminum frame. There are a total of 8 panel mounting clamps for 2901230 and 10 clamps for 2901240.
- Step 5:** Tighten the screws that pass through the panel mounting clamps until the plastic

2901230/2901240/2901250 Panel PC

caps at the front of all the screws are firmly secured to the panel (**Figure 3-25**).

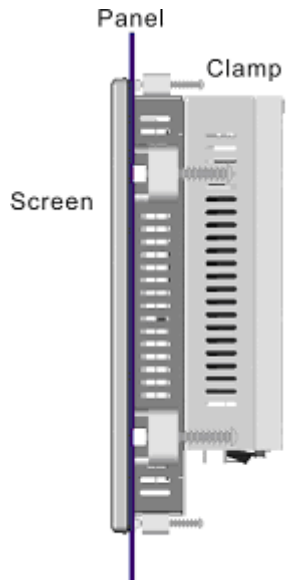

Figure 3-25: Tighten the Panel Mounting Clamp Screws (2901230/2901240)

3.9.2.2 2901250 Panel Mounting

To mount the 2901250 flat panel PC into a panel, please follow the steps below.

Step 1: Install the panel mounting kit onto the 2901250 real panel (**Figure 3-26**).

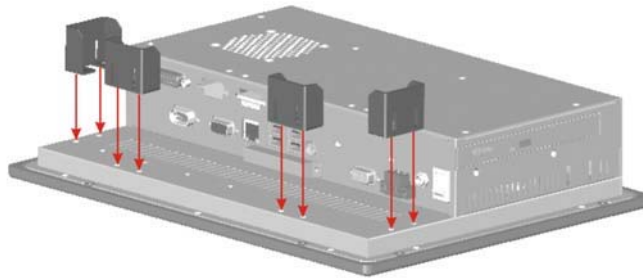

Figure 3-26: 2901250 Panel Mounting Kit

Step 2: Select the position in the panel to mount the 2901250.

Step 3: Cut out a section from the panel that corresponds to the dimensions of the

2901230/2901240/2901250 Panel PC

2901250 flat panel PC chassis. The panel section that is cut out must be smaller than the size of the aluminum frame that surrounds the 12.1" TFT LCD panel but just large enough for the chassis to fit through (**Figure 3-27**).

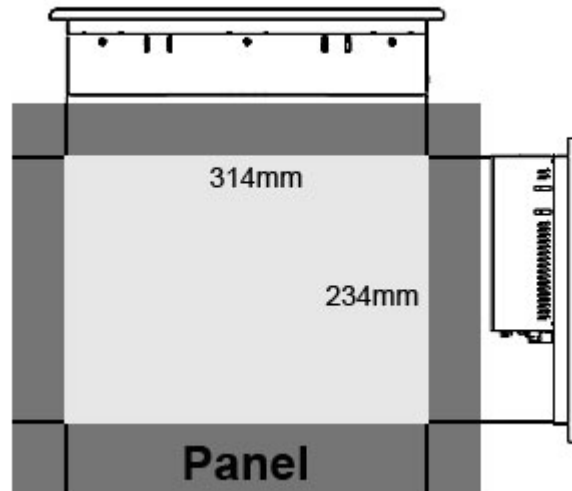

Figure 3-27: Suggested Panel Cut Out Size for 2901250

- Step 4:** Slide the 2901250 through the hole until the aluminum frame is flush against the panel.
- Step 5:** Insert the panel mounting clamps into the pre-formed holes along the edges of the chassis, behind the aluminum frame. There are a total of 8 panel mounting clamps.
- Step 6:** Tighten the screws that pass through the panel mounting clamps until the plastic caps at the front of all the screws are firmly secured to the panel (**Figure 3-28**).

2901230/2901240/2901250 Panel PC

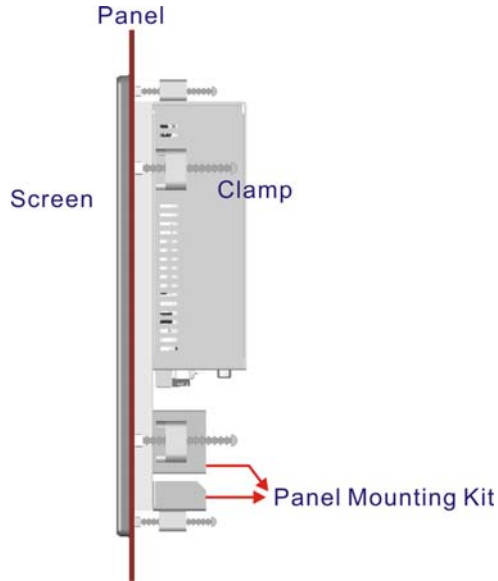

Figure 3-28: Tighten the Panel Mounting Clamp Screws (2901250)

3.9.3 Arm Mounting

The flat panel PC is VESA (Video Electronics Standards Association) compliant and can be mounted on an arm with a 100mm interface pad. To mount the flat panel PC on an arm, please follow the steps below.

Step 1: The arm is a separately purchased item. Please correctly mount the arm onto the surface it uses as a base. To do this, refer to the installation documentation that came with the mounting arm.



NOTE:

When purchasing the arm please ensure that it is VESA compliant and that the arm has a 100mm interface pad. If the mounting arm is not VESA compliant it cannot be used to support the flat panel PC.

Step 2: Once the mounting arm has been firmly attached to the surface, lift the flat panel PC onto the interface pad of the mounting arm.

Step 3: Align the retention screw holes on the mounting arm interface with those in the

2901230/2901240/2901250 Panel PC

flat panel PC. The flat panel PC arm mount retention screw holes are shown in **Figure 3-29**.

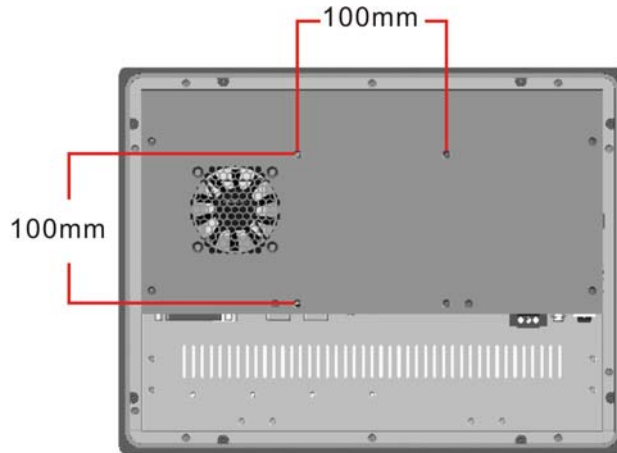

Figure 3-29: Arm Mounting Retention Screw Holes

Step 4: Secure the flat panel PC to the interface pad by inserting four retention screws through the bottom of the mounting arm interface pad and into the flat panel PC.

3.9.4 Cabinet and Rack Installation

The 2901230, 2901240 and 2901250 flat panel PC can be installed into a cabinet or rack. To do this, please follow the steps below.

3.9.4.1 2901230 Cabinet and Rack Installation

Step 1: Slide the rear chassis of the 2901230 flat panel PC through the rack/cabinet bracket until the aluminum frame is flush against the front of the bracket (**Figure 3-30**).

2901230/2901240/2901250 Panel PC

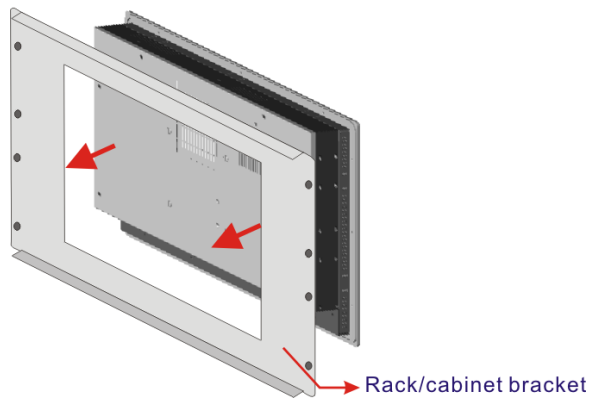

Figure 3-30: The Rack/Cabinet Bracket

Step 2: Insert the rack mounting clamps into the pre-formed holes along the edges of the 2901230, behind the metal frame. The required number of mounting clamps should be eight.

Step 3: Tighten the screws that pass through the rack mounting clamps until the plastic caps at the front of all the screws are firmly secured to the bracket (**Figure 3-31**).

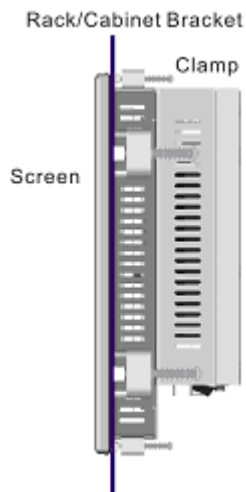

Figure 3-31: Secure the 2901230 Rack/Cabinet Bracket

Step 4: Slide the 2901230 flat panel PC with the attached rack/cabinet bracket into a rack or cabinet (**Figure 3-32**).

2901230/2901240/2901250 Panel PC

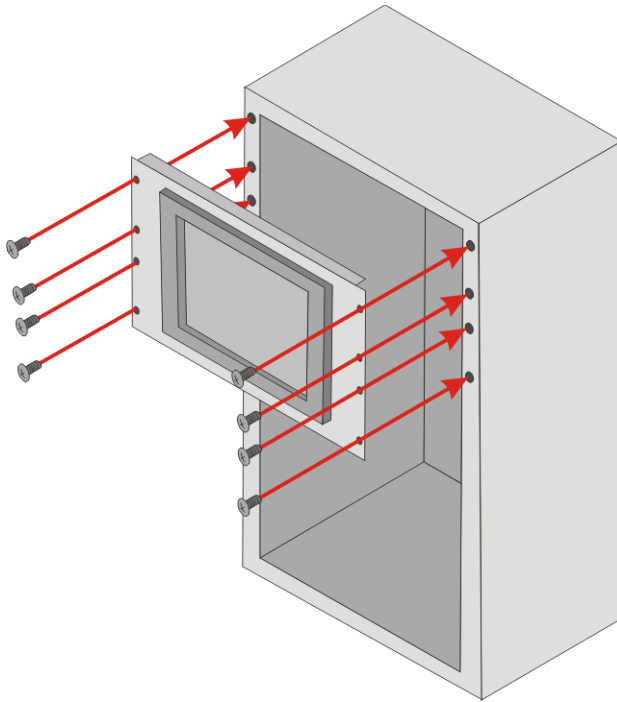

Figure 3-32: Install into a Rack/Cabinet

Step 5: Once the 2901230 flat panel PC with the attached rack/cabinet bracket has been properly inserted into the rack or cabinet, secure the front of the rack/cabinet bracket to the front of the rack or cabinet (**Figure 3-32**).

3.9.4.2 2901240/2901250 Cabinet and Rack Installation

Step 1: The back of the aluminum frame surrounding the 2901240/2901250 TFT LCD screen has retention screw holes (2901240 has 10 holes and 2901250 has 8 holes) for a cabinet/rack installation bracket.



NOTE:

When purchasing the cabinet/rack installation bracket make sure it is compatible with both the 2901240/2901250 flat panel PC and the rack/cabinet into which the 2901240/2901250 is installed.

Step 2: Slide the rear chassis of the 2901240/2901250 flat panel PC through the

2901230/2901240/2901250 Panel PC

rack/cabinet bracket until the rear side of the LCD screen frame is flush against the front of the bracket.

Step 3: Make sure the retention screw holes at the rear of the LCD screen are aligned with the retention screw holes in the rack/cabinet bracket.

Step 4: Secure the rack/cabinet bracket to the 2901250 flat panel PC by inserting the retention screws (**Figure 3-33**).

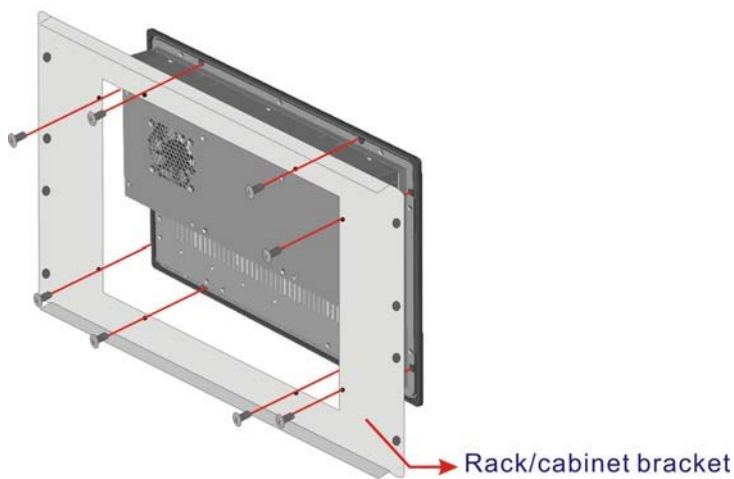

Figure 3-33: Secure the 2901240/2901250 Rack/Cabinet Bracket

Step 5: Follow the **Step 4** and **Step 5** of the 2901230 Cabinet and Rack Installation procedures to complete the whole installation process.

3.10 Rear Panel Connectors

3.10.1 LCD Panel Connection

To connect the flat panel PC to a second monitor, a conventional CRT VGA monitor connector is located on the bottom panel. This panel is a 15-pin, female D-SUB connector.



NOTE:

To use the dual screen option, please configure this option in the **Intel® Extreme Graphics** configuration program. To do this, after Windows has

2901230/2901240/2901250 Panel PC

loaded, open the **Control Panel**, locate the **Intel® Extreme Graphics** icon, click on it. Once open, an option for **Multiple Display** is available. Select this option and select notebook as the primary device.

3.10.2 Ethernet Connection

The rear panel RJ-45 connector can be connected to an external LAN and provide internet connectivity to the flat panel PC.

3.10.3 USB Connection

The rear panel USB connectors provide easier and quicker access to external USB devices. The rear panel USB connector is a standard connector and can easily be connected to other USB devices.

3.10.4 Keyboard and Mouse Connection

Two PS/2 connectors on the bottom panel facilitate the connection of a mouse and a keyboard. To connect either device, plug the PS/2 connector at the end of the device (keyboard or mouse) cable into the PS/2 connector on the bottom panel.

3.11 System Maintenance

If the components of the flat panel PC fail, they must be replaced. Please contact the system reseller or vendor to purchase the replacement parts. Replacement instructions for the above listed components are described below.



NOTE:

A user cannot replace a motherboard. If the motherboard fails it must be shipped back to Global American, Inc. to be replaced. Please contact the system vendor, reseller or a Global American, Inc. sales person directly.

Appendix

A

Interface Connectors

A.1 Peripheral Interface Connectors

The 2901250 flat panel PC motherboard, the 3302150 comes with a number of peripheral interface connectors and configuration jumpers listed in **Chapter 2**. The pinouts for these connectors are listed below:

PIN NO.	DESCRIPTION	PIN NO.	DESCRIPTION
1	GND	2	VCC
3	OUT0	4	OUT1
5	OUT2	6	OUT3
7	IN0	8	IN1
9	IN2	10	IN3

Table A-1: 4-bit GPIO Connector Pinouts

PIN NO.	DESCRIPTION
1	Button 1
2	Button 2

Table A-2: Power Button Connector Pinouts

PIN NO.	DESCRIPTION
1	5VSB
2	GND
3	PSON

Table A-3: Power Connector Pinouts

PIN NO.	DESCRIPTION	PIN NO.	DESCRIPTION
1	LINE_OUT-R	2	LINE_IN-R
3	GND	4	GND
5	LINE_OUT-L	6	LINE_IN-L
7	GND	8	GND
9	MIC-IN	10	NC

Table A-4: Audio Connector Pinouts

2901230/2901240/2901250 Panel PC

PIN NO.	DESCRIPTION
1	GND
2	GND
3	VCC12
4	VCC12

Table A-5: 12V Power Connector Pinouts

PIN NO.	DESCRIPTION	PIN NO.	DESCRIPTION
1	GROUND	26	VCC-IN CHECK1
2	DATA 3	27	DATA 11
3	DATA 4	28	DATA 12
4	DATA 5	29	DATA 13
5	DATA 6	30	DATA 14
6	DATA 7	31	DATA 15
7	HDC_CS0#	32	HDC_CS1
8	N/C	33	N/C
9	GROUND	34	IOR#
10	N/C	35	IOW#
11	N/C	36	N/C
12	N/C	37	INTERRUPT
13	VCC_COM	38	VCC_COM
14	N/C	39	CSEL
15	N/C	40	N/C
16	N/C	41	HDD_RESET
17	N/C	42	IORDY
18	SA2	43	N/C
19	SA1	44	VCC_COM
20	SA0	45	HDD_ACTIVE#
21	DATA 0	46	N/C
22	DATA 1	47	DATA 8
23	DATA 2	48	DATA 9
24	N/C	49	DATA 10

25	VCC-IN CHECK2	50	GROUND
----	---------------	----	--------

Table A-6: CFII Socket Pinouts

PIN NO.	DESCRIPTION
1	Fan Speed Detect
2	+12V
3	GND

Table A-7: Fan Connector Pinouts

PIN NO.	DESCRIPTION	PIN NO.	DESCRIPTION
1	RESET#	2	GROUND
3	DATA 7	4	DATA 8
5	DATA 6	6	DATA 9
7	DATA 5	8	DATA 10
9	DATA 4	10	DATA 11
11	DATA 3	12	DATA 12
13	DATA 2	14	DATA 13
15	DATA 1	16	DATA 14
17	DATA 0	18	DATA 15
19	GROUND	20	N/C
21	IDE DRQ	22	GROUND
23	IOW#	24	GROUND
25	IOR#	26	GROUND
27	IDE CHRDY	28	GROUND
29	IDE DACK	30	GROUND-DEFAULT
31	INTERRUPT	32	N/C
33	SA1	34	N/C
35	SA0	36	SA2
37	HDC CS0#	38	HDC CS1#
39	HDD ACTIVE#	40	GROUND
41	VCC	42	VCC
43	GROUND	44	N/C

Table A-8: IDE Connector Pinouts

2901230/2901240/2901250 Panel PC

PIN NO.	DESCRIPTION
1	BKLTCTL
2	GND
3	+12V
4	GND
5	BKLEN

Table A-9: Inverter Connector Pinouts

PIN NO.	DESCRIPTION
1	VCC
2	N/C
3	RXD
4	GND
5	TXD

Table A-10: IR Interface Connector Pinouts

PIN NO.	DESCRIPTION
1	VCC5
2	MOUSE DATA
3	MOUSE CLOCK
4	KEYBOARD DATA
5	KEYBOARD CLOCK
6	GND

Table A-11: Keyboard/Mouse Connector Pinouts

PIN NO.	DESCRIPTION
1	+5V
2	GND
3	VCC5 LED+
4	GND
5	HDD LED+
6	HDD LED-

Table A-12: LED Connector Pinouts

PIN NO.	Description	PIN NO.	Description
2	GND	1	NC
4	AY0-	3	AY0+
6	AY1-	5	AY1+
8	AY2-	7	AY2+
10	AYCLK-	9	AYCLK+
12	AY3-	11	AY3+
14	GND	13	GND
16	BY0-	15	BY0+
18	BY1-	17	BY1+
20	BY2-	19	BY2+
22	BYCLK-	21	BYCLK+
24	BY3-	23	BY3+
26	GND	25	GND
28	LCDVCC	27	LCDVCC
30	LCDVCC	29	LCDVCC

Table A-13: LVDS Connector Pinouts

PIN	DESCRIPTION	PIN	DESCRIPTION
1	STROBE#	14	AUTO FORM FEED #
2	DATA0	15	ERROR#
3	DATA1	16	INITIALIZE#
4	DATA2	17	PRINTER SELECT LN#
5	DATA3	18	GND
6	DATA4	19	GND
7	DATA5	20	GND
8	DATA6	21	GND
9	DATA7	22	GND
10	ACKNOWLEDGE#	23	GND
11	BUSY	24	N/C
12	PAPER EMPTY	25	GND

2901230/2901240/2901250 Panel PC

13	PRINTER SELECT	
----	----------------	--

Table A-14: Parallel Port Connector Pinouts

PIN	Description	PIN	Description	PIN	Description	PIN	Description
A1	GROUND	B1	NC/SERIRQ	C1	+5V	D1	AD0
A2	VIO	B2	AD2	C2	AD1	D2	+5V
A3	AD5	B3	GND	C3	AD4	D3	AD3
A4	CBE0-	B4	AD7	C4	GND	D4	AD6
A5	GND	B5	AD9	C5	AD8	D5	GND
A6	AD11	B6	VIO	C6	AD10	D6	N66EV
A7	AD14	B7	AD13	C7	GND	D7	AD12
A8	+3.3V	B8	CBE1-	C8	AD15	D8	+3.3V
A9	SERR-	B9	GND	C9	SBO-	D9	PAR
A10	GND	B10	PERR-	C10	+3.3V	D10	SDONE
A11	STOP-	B11	+3.3V	C11	LOCK-	D11	GND
A12	+3.3V	B12	TRDY-	C12	GND	D12	DEVSEL-
A13	FRAME-	B13	GND	C13	IRDY-	D13	+3.3V
A14	GND	B14	AD16	C14	+3.3V	D14	CBE2-
A15	AD18	B15	+3.3V	C15	AD17	D15	GND
A16	AD21	B16	AD20	C16	GND	D16	AD19
A17	+3.3V	B17	AD23	C17	AD22	D17	+3.3V
A18	IDSEL0	B18	GND	C18	IDSEL1	D18	IDSEL2
A19	AD24	B19	CBE3-	C19	VIO	D19	IDSEL3
A20	GND	B20	AD26	C20	AD25	D20	GND
A21	AD29	B21	+5V	C21	AD28	D21	AD27
A22	+5V	B22	AD30	C22	GND	D22	AD31
A23	REQ0-	B23	GND	C23	REQ1-	D23	VIO
A24	GND	B24	REQ2-	C24	+5V	D24	GNT0-
A25	GNT1-	B25	VIO	C25	GNT2-	D25	GND
A26	+5V	B26	PCICLK0	C26	GND	D26	PCICLK1
A27	PCICLK2	B27	+5V	C27	PCICLK3	D27	GND
A28	GND	B28	INTD-	C28	+5V	D28	PCIRST-

2901230/2901240/2901250 Panel PC

A29	+12V	B29	INTA-	C29	INTB-	D29	INTC-
A30	-12v	B30	REQ3-	C30	GNT3-	D30	GND/3.3V

Table A-15: PCI-104 Connector Pinouts

PIN NO.	DESCRIPTION
1	Reset 1
2	Reset 2

Table A-16: Reset Connector Pinouts

PIN NO.	DESCRIPTION
1	GND
2	TX0+
3	TX0-
4	GND
5	RX0-
6	RX0+
7	GND

Table A-17: SATA Connector Pinouts

PIN NO.	DESCRIPTION	PIN NO.	DESCRIPTION
1	DCD#	2	DSR#
3	RxD	4	RTS#
5	TxD	6	CTS#
7	DTR#	8	RI#
9	GND	10	GND
11	TxD485+	12	TxD485-
13	RxD485+	14	RxD485-

Table A-18: COM2 Connector Pinouts

PIN NO.	DESCRIPTION	PIN NO.	DESCRIPTION
1	DCD#	2	DSR#
3	RX	4	RTS#

2901230/2901240/2901250 Panel PC

5	TX	6	CTS#
7	DTR#	8	RI #
9	GND	10	GND

Table A-19: COM3 Connector Pinouts

PIN NO.	DESCRIPTION	PIN NO.	DESCRIPTION
1	DCD#	2	DSR#
3	RX	4	RTS#
5	TX	6	CTS#
7	DTR#	8	RI #
9	GND	10	GND

Table A-20: COM4 Connector Pinouts

PIN NO.	DESCRIPTION	PIN NO.	DESCRIPTION
1	USBVCC4	2	GND
3	D4F-	4	D5F+
5	D4F+	6	D5F-
7	GND	8	USBVCC4

Table A-21: USB Connector Pinouts

2901230/2901240/2901250 Panel PC

Any advice or comments about our products and service, or anything we can help you with please don't hesitate to contact with us. We will do our best to support you for your products, projects and business.

Global American Inc.

Address: 17 Hampshire Drive
Hudson, NH 03051

TEL: Toll Free (U.S. Only) 800-833-8999
(603)886-3900

FAX: (603)886-4545

Website: <http://www.globalamericaninc.com>

E-Mail: salesinfo@globalamericaninc.com

