



integration with integrity

User's Manual

Mini-ITX Motherboard 2807790

Version 1.0, August 2007

Copyrights

This manual is copyrighted and all rights are reserved. It does not allow any non authorization in copied, photocopied, translated or reproduced to any electronic or machine readable form in whole or in part without prior written consent from the manufacturer.

In general, the manufacturer will not be liable for any direct, indirect, special, incidental or consequential damages arising from the use of inability to use the product or documentation, even if advised of the possibility of such damages. The manufacturer keeps the rights in the subject to change the contents of this manual without prior notices in order to improve the function design, performance, quality and reliability. The author assumes no responsibility for any errors or omissions, which may appear in this manual, nor does it make a commitment to update the information contained herein.

Trademarks

Intel is a registered trademark of Intel Corporation.

Award is a registered trademark of Award Software, Inc.

All other trademarks, products and or product's name mentioned herein are mentioned for identification purposes only, and may be trademarks and/or registered trademarks of their respective companies or owners.

Safety Instructions

1. Always read the safety instructions carefully.
2. Keep this User's Manual for future reference.
3. Keep this equipment away from humidity.
4. Lay this equipment on a reliable flat surface before setting it up.
5. The openings on the enclosure are for air convection hence protects the equipment from overheating. DO NOT COVER THE OPENINGS.
6. Make sure the voltage of the power source and adjust properly 110/220V before connecting the equipment to the power inlet.
7. Place the power cord such a way that people can not step on it. Do not place anything over the power cord.
8. Always Unplug the Power Cord before inserting any add-on card or module.
9. All cautions and warnings on the equipment should be noted.
10. Never pour any liquid into the opening that could damage or cause electrical shock.
11. If any of the following situations arises, get the equipment checked by service personnel:
 - † The power cord or plug is damaged.
 - † Liquid has penetrated into the equipment.
 - † The equipment has been exposed to moisture.
 - † The equipment does not work well or you can not get it work according to User's Manual.
 - † The equipment has dropped and damaged.
 - † The equipment has obvious sign of breakage.
12. DO NOT LEAVE THIS EQUIPMENT IN AN ENVIRONMENT UNCONDITIONED, STORAGE TEMPERATURE ABOVE 60°C (140°F), IT MAY DAMAGE THE EQUIPMENT.



CAUTION: Danger of explosion if battery is incorrectly replaced. Replace only with the same or equivalent type recommended by the manufacturer.



警告使用者:

這是甲類的資訊產品，在居住的環境中使用時，可能會造成無線電干擾，在這種情況下，使用者會被要求採取某些適當的對策。



廢電池請回收

For better environmental protection, waste batteries should be collected separately for recycling or special disposal.

FCC-B Radio Frequency Interference Statement

This equipment has been tested and found to comply with the limits for a Class B digital device, pursuant to Part



15 of the FCC Rules. These limits are designed to provide reasonable protection against harmful interference in a residential installation. This equipment generates, uses and can radiate radio frequency energy and, if not installed and used in accordance with the instructions, may cause harmful interference to radio communications. However, there is no guarantee that interference will not occur in a particular installation. If this equipment does cause harmful interference to radio or television reception, which can be determined by turning the equipment off and on, the user is encouraged to try to correct the interference by one or more of the measures listed below.

- † Reorient or relocate the receiving antenna.
- † Increase the separation between the equipment and receiver.
- † Connect the equipment into an outlet on a circuit different from that to which the receiver is connected.
- † Consult the dealer or an experienced radio/television technician for help.

Notice 1

The changes or modifications not expressly approved by the party responsible for compliance could void the user's authority to operate the equipment.

Notice 2

Shielded interface cables and A.C. power cord, if any, must be used in order to comply with the emission limits.

VOIR LA NOTICED'INSTALLATION AVANT DE RACCORDER AU RESEAU.



This device complies with Part 15 of the FCC Rules. Operation is subject to the following two conditions:

- (1) this device may not cause harmful interference, and*
- (2) this device must accept any interference received, including interference that may cause undesired operation.*

CONTENTS

Technical Support	ii
Safety Instructions	iii
FCC-B Radio Frequency Interference Statement	iv
WEEE (Waste Electrical and Electronic Equipment) Statement	v
Chapter 1 Product Overview	1-1
Mainboard Specifications	1-2
Block Diagram	1-4
Mainboard Layout	1-5
Power Consumption	1-6
Safety Compliance & MTBF	1-7
Board Dimension	1-8
Back Panel & I/O Shield Drawing	1-9
Chapter 2 Hardware Setup	2-1
Quick Components Guide	2-2
Memory	2-3
CPU (Central Processing Unit)	2-4
Power Supply	2-7
Back Panel	2-8
Connectors	2-10
Jumpers	2-16
Slots	2-17
Chapter 3 System Resources	3-1
Watch Dog Timer Setting	3-2
AMI POST Code	3-3
Resource List	3-6

Mainboard Specifications

Processor Support

- AMD Sempron ,Athlon 64/64 X2 (Dual Core) processor with AM2 package
- 4-pin CPU fan pinheader with Smart Fan Speed Control

Supported FSB

- Hyper Transport supporting speed up to 1 GHz (2000MT/s)

Chipset

- Northbridge : AMD RS690T
- Southbridge : AMD SB600

Memory Support

- DDR2 400/533/667/800 (4GB Max)
- 2 DDR2 SO-DIMM slots (unbuffered)

LAN

- 2 PCI-E Gb LAN by Marvell 88E8056

Audio

- Realtek ALC888 7.1-channel HDA codec
- 6 watt amplifier

IDE

- 1 40-pin IDE connector
- Supports 2 IDE devices

SATA

- 2 SATA II ports by SB600
- Supports storage and data transfers at up to 300MB/s

Expansion Slots

- 1 PCI slot
- 1 Mini PCI-E socket

Connectors

- **Rear I/O**
 - 1 PS/2 mouse port
 - 1 PS/2 keyboard port
 - 2 COM ports
 - 1 VGA/ HDMI stack connector
 - 4 USB ports
 - 5 flexible audio jacks
 - 1 optical SPDIF-out jack
- **Onboard Connector**
 - 2 USB connectors (4 ports)
 - 1 parallel port connector (LPT)
 - 1 LVDS connector
 - 1 TV-Out connector
 - 1 amplifier connector
 - 1 front panel connector
 - 1 SMBUS connector
 - 1 CPU fan connector
 - 1 system fan connector
 - 2 SATA connectors
 - 1 Chassis Intrusion connector

Form Factor

- Mini-ITX (17.0cm X17.0cm)

Mounting

- 4 mounting holes

Environmental

- **Operating Temperature**
 - Temperature: -10°C ~ 70°C
 - Humidity: 0% ~ 85% RH
- **Storage Temperature**
 - Temperature: -20°C ~ 80°C
 - Humidity: 25% ~ 90% RH

Block Diagram

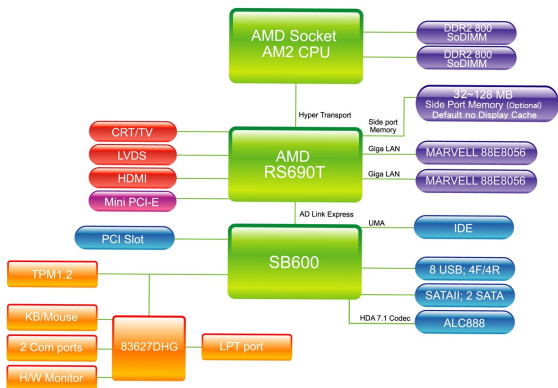

Mainboard Layout

Backpanel I/O

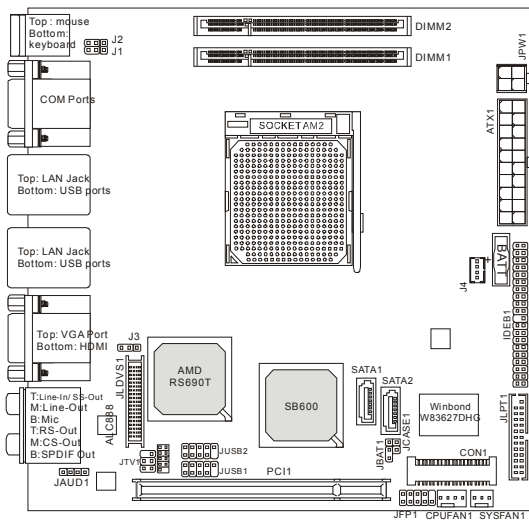

(2807790 v1.X) Mini ITX Mainboard

Power Consumption

Component	Description
CPU	AMD Athlon™ 64 x2 Dual Core 2G
DDR2	1024MB DDR2 533 *2
HDD	Maxtor 80G 2807790
ODD	NEC DVD-Multi Record ND-4550A

12Vp		12V	5V	3.3V	5VSB	-12V	W
AMD ThermNow! Utility	4.2	0.81	3.03	1.08	0.032	0.028	79.33
Particle Fuly + VCD + Xcopy	3.07	1.01	4.66	1.07	0.039	0.02	76.226
3Dmark 2005	2.81	0.84	4.27	1.06	0.04	0.042	69.352
Idle	0.82	0.81	3.09	1.17	0.024	0.017	39.195
S3	0	0	0	0	0.512	0	2.56

Safety compliance & MTBF

Safety compliance

Certification	Standard number		Title of standard
CE	RFI	EN 55022:1998+A1:2000+A2:2003 Class B	Product family standard
		EN 6100-3-2:2000 Class D	Limits for harmonic current emission
		EN 6100-3-3:1995+A1:2001	Limitation of voltage fluctuation and flicker in low-voltage supply system
	Immunity	EN 55024:1998+A1:2001+A2:2003	Product family standard
BSMI	CNS 13438 乙類(2006年版)		
C-Tick	AS/NZS CISPR 22:2004		
FCC	FCC CFR Title 47 Part 15 Subpart B: 2005 Class B		
	CISPR 22: 2005		
VCCI	VCCI V-3:2004, Class B		
	VCCI V-4:2004, Class B		

MTBF - Reliability Prediction

Calculation Model	Operation temperature(°C)	Operating Environment	Duty Cycle	MTBF(hr.)
Telcordia Issue 1	35	GF, GU - Ground Fixed, Uncontrolled	100%	93,411
Telcordia Issue 1	55	GF, GU - Ground Fixed, Uncontrolled	100%	52,174

Board Dimension

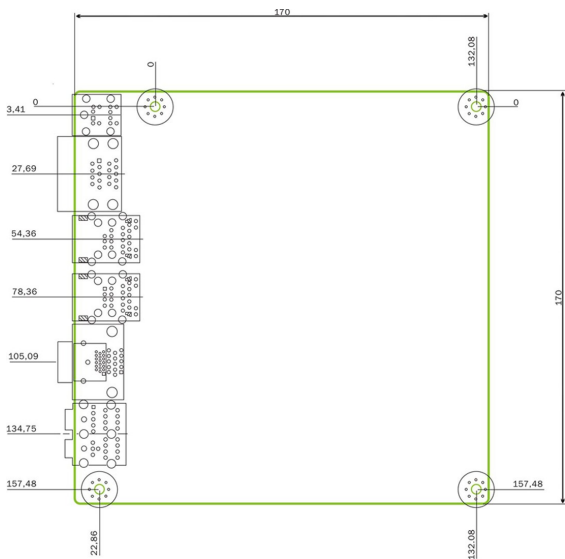

Back Panel & I/O Shield Drawing

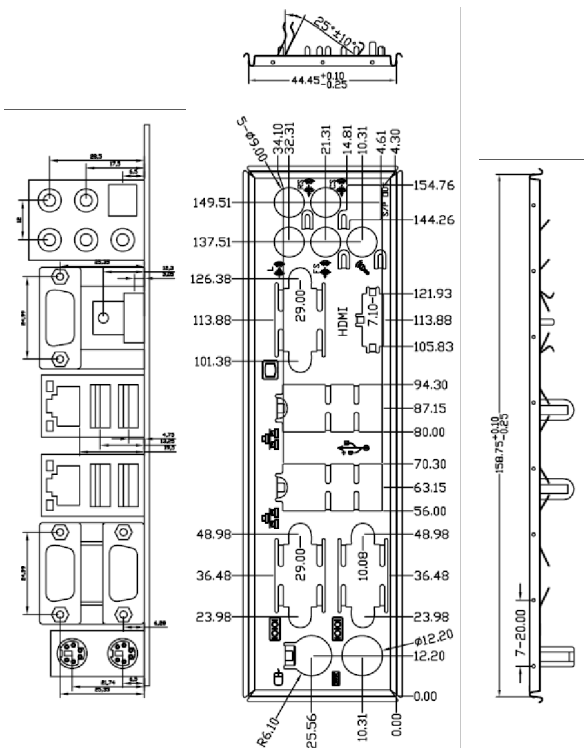

Chapter 2

Hardware Setup

This chapter provides you with the information about hardware setup procedures. While doing the installation, be careful in holding the components and follow the installation procedures. For some components, if you install in the wrong orientation, the components will not work properly.

Use a grounded wrist strap before handling computer components. Static electricity may damage the components.

Quick Components Guide

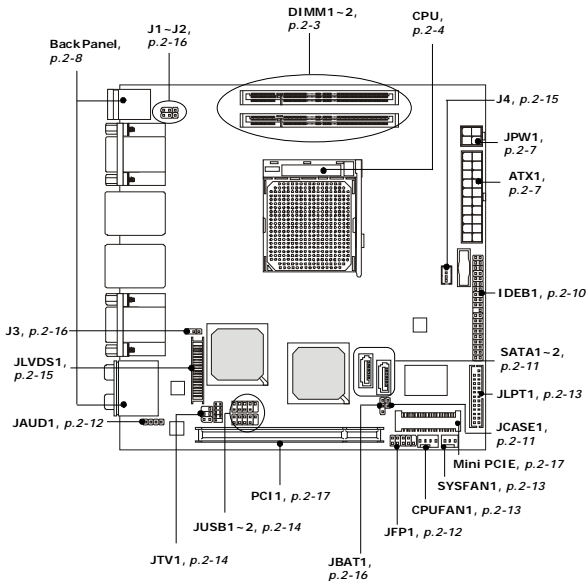

Memory

The mainboard provides two 200-pin **unbuffered DDR2 400/533/667/800** SO-DIMM slots and supports up to 4GB system memory.

DIMM2
200-pin, unbuffered



DIMM1
200-pin, unbuffered



Installing Memory Modules

1. The memory module has only one notch on the center and will only fit in the right orientation.
2. Insert the memory module vertically into the SO-DIMM slot. Then push it in until the golden finger on the memory module is deeply inserted in the SO-DIMM slot.



Important

You can barely see the golden finger if the memory module is properly inserted in the DIMM slot.

3. The clip at each side of the SO-DIMM slot will automatically close.



Important

*To ensure the installations of memory and CPU successfully, please note that to **insert the memory modules first** before install CPU and cooler set. And please always insert the memory module into the **DIMM2 first**.*

CPU (Central Processing Unit)

The mainboard supports AMD® Athlon64/ 64x2 & Sempron processors. The mainboard uses a CPU socket called Socket AM2 for easy CPU installation. When you are installing the CPU, **make sure the CPU has a heat sink and a cooling fan attached on the top to prevent overheating.** If you do not have the heat sink and cooling fan, contact your dealer to purchase and install them before turning on the computer.



Important

Overheating

Overheating will seriously damage the CPU and system. Always make sure the cooling fan can work properly to protect the CPU from overheating. Make sure that you apply an even layer of thermal paste (or thermal tape) between the CPU and the heatsink to enhance heat dissipation.

Replacing the CPU

While replacing the CPU, always turn off the ATX power supply or unplug the power supply's power cord from the grounded outlet first to ensure the safety of CPU.

CPU Installation Procedures for Socket AM2

1. Please turn off the power and unplug the power cord before installing the CPU.
2. Pull the lever sideways away from the socket. Make sure to raise the lever up to a 90-degree angle.
3. Look for the gold arrow of the CPU. The gold arrow should point as shown in the picture. The CPU can only fit in the correct orientation.
4. If the CPU is correctly installed, the pins should be completely embedded into the socket and can not be seen. Please note that any violation of the correct installation procedures may cause permanent damages to your mainboard.
5. Press the CPU down firmly into the socket and close the lever. As the CPU is likely to move while the lever is being closed, always close the lever with your fingers pressing tightly on top of the CPU to make sure the CPU is properly and completely embedded into the socket.

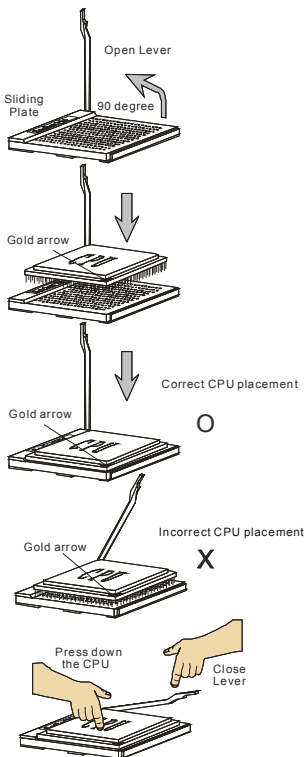

Installing AMD Socket AM2 CPU Cooler Set

When you are installing the CPU, **make sure the CPU has a heat sink and a cooling fan attached on the top to prevent overheating.** If you do not have the heat sink and cooling fan, contact your dealer to purchase and install them before turning on the computer.



Important

Mainboard photos shown in this section are for demonstration of the cooler installation for Socket AM2 CPUs only. The appearance of your mainboard may vary depending on the model you purchase.

1. Position the cooling set onto the retention mechanism.

Hook one end of the clip to hook first.

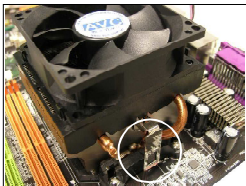

2. Then press down the other end of the clip to fasten the cooling set on the top of the retention mechanism. Locate the Fix Lever and lift up it .

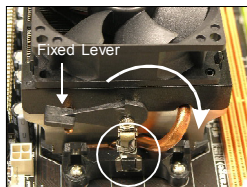

3. Fasten down the lever.

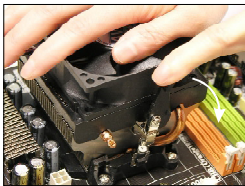

4. Attach the CPU Fan cable to the CPU fan connector on the mainboard.

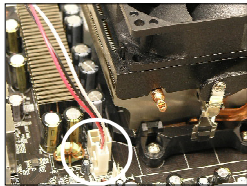

Power Supply

ATX 20-Pin System Power Connector: ATX1

This connector allows you to connect to an ATX power supply. To connect to the ATX power supply, make sure the plug of the power supply is inserted in the proper orientation and the pins are aligned. Then push down the power supply firmly into the connector.

ATX1

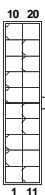

ATX1 Pin Definition

PIN	SIGNAL	PIN	SIGNAL
1	3.3V	11	3.3V
2	3.3V	12	-12V
3	GND	13	GND
4	5V	14	PS_ON
5	GND	15	GND
6	5V	16	GND
7	GND	17	GND
8	PW_OK	18	-5V
9	5V_SB	19	5V
10	12V	20	5V

ATX 12V Power Connector: JPW1

This 12V power connector JPW1 is used to provide power to the CPU.



Pin Definition

PIN	SIGNAL
1	GND
2	GND
3	12V
4	12V



Important

Power supply of 350watts (and above) is highly recommended for system stability.

Back Panel

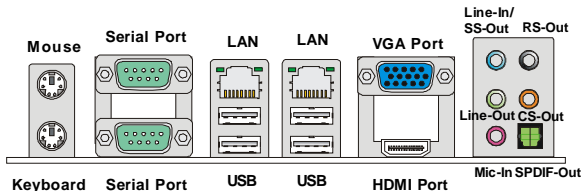

► Mouse/Keyboard Connector

The standard PS/2[®] mouse/keyboard DIN connector is for a PS/2[®] mouse/keyboard.

► Serial Port

The serial port is a 16550A high speed communications port that sends/ receives 16 bytes FIFOs. You can attach a serial mouse or other serial devices directly to the connector.

► LAN (RJ-45) Jacks

The standard RJ-45 jacks are for connection to Local Area Network (LAN). You can connect network cables to them.

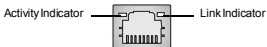

		Left LED	Right LED
LED Color		Active LED	100M/1000M Speed LED
10M Cable Plug-in	No Transmission	Yellow	Green/Orange
	Transition	OFF	OFF
100M Cable Plug-in	No Transmission	OFF	OFF
	Transition	Yellow(Blinking)	Green(Lighting)
1000M Cable Plug-in	No Transmission	OFF	Green(Lighting)
	Transition	Yellow(Blinking)	Orange(Lighting)
In S3/S4/S5 Standby State		OFF	OFF

► USB Connectors

The UHCI (Universal Host Controller Interface) Universal Serial Bus root is for attaching USB devices such as keyboard, mouse, or other USB-compatible devices.

► VGA Port

The DB15-pin female connector is provided for video monitors.

► HDMI Port

The High-Definition Multimedia Interface (HDMI) is an all-digital audio/video interface capable of transmitting uncompressed streams. HDMI supports all TV format, including standard, enhanced, or high-definition video, plus multi-channel digital audio on a single cable.

► Audio Port Connectors

These audio connectors are used for audio devices. You can differentiate the color of the audio jacks for different audio sound effects.

- **Line-In/ SS-Out (Blue)** - Line In / Side-Surround Out in 7.1 channel mode, is used for external CD player, tapeplayer or other audio devices.
- **Line-Out (Green)** - Line Out, is a connector for speakers or headphones.
- **Mic (Pink)** - Mic, is a connector for microphones.
- **RS-Out (Black)** - Rear-Surround Out in 4/ 5.1/ 7.1 channel mode.
- **CS-Out (Orange)** - Center/ Subwoofer Out in 5.1/ 7.1 channel mode.

► Optical S/PDIF-Out connector

This SPDIF (Sony & Philips Digital Interconnect Format) connector is provided for digital audio transmission to external speakers through a fiber cable.

Connectors

IDE Connector: IDEB1

The mainboard has a 32-bit Enhanced PCI IDE and Ultra DMA 33/66/100/133 controller that provides PIO mode 0~4, Bus Master, and Ultra DMA 33/66/100/133 function. You can connect hard disk drives, CD-ROM and other IDE devices.

The Ultra ATA133 interface boosts data transfer rates between the computer and the hard drive up to 133 megabytes (MB) per second.

IDEB1



Important

If you install two IDE devices, you must configure the second drive to Slave mode by setting its jumper. Refer to the hard disk documentation supplied by hard disk vendors for jumper setting instructions.

Serial ATA Connectors: SATA1, SATA2

SATA1~SATA2 are high-speed SATA interface ports and support SATA data rates of 300MB/s. Each SATA connector can connect to 1 hard disk device and is fully compliant with Serial ATA 2.0 specifications.

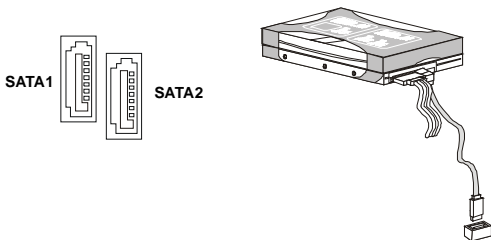

Important

Please do not fold the Serial ATA cable into 90-degree angle. Otherwise, data loss may occur during transmission.

Chassis Intrusion Connector: JCASE1

This connector connects to the chassis intrusion switch cable. If the chassis is opened, the chassis intrusion mechanism will be activated. The system will record this status and show a warning message on the screen. To clear the warning, you must enter the BIOS utility and clear the record.

1 □ CINTRU
2 □ GND

JCASE1

Audio Amplifier Connector: JAUD1

The 6W JAUD1 is used to connect audio amplifiers to enhance audio performance.



Pin Definition

PIN	SIGNAL
1	AMP_R+
2	AMP_R-
3	AMP_L+
4	AMP_L-

Front Panel Connector: JFP1

The mainboard provides one front panel connector for electrical connection to the front panel switches and LEDs. The JFP1 is compliant with Intel® Front Panel I/O Connectivity Design Guide.

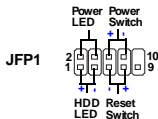

JFP1 Pin Definition

PIN	SIGNAL	DESCRIPTION
1	HD_LED +	Hard disk LED pull-up
2	FPPWR/SLP	Power LED pull-up
3	HD_LED -	Hard disk active LED
4	FPPWR/SLP	Power LED pull-up
5	RST_SW -	Reset Switch low reference pull-down to GND
6	PWR_SW +	Power Switch high reference pull-up
7	RST_SW +	Reset Switch high reference pull-up
8	PWR_SW -	Power Switch low reference pull-down to GND
9	RSVD_DNU	Reserved. Do not use.

Fan Power Connectors: CPUFAN1, SYSFAN1

The fan power connectors support system cooling fan with +12V. When connecting the wire to the connectors, always take note that the red wire is the positive and should be connected to the +12V, the black wire is Ground and should be connected to GND. If the mainboard has a System Hardware Monitor chipset on-board, you must use a specially designed fan with speed sensor to take advantage of the CPU fan control.

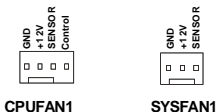

Important

Please refer to the recommended CPU fans at A D's official website or consult the vendors for proper CPU cooling fan.

Parallel Port Header: JLPT1

The mainboard provides a 26-pin header for connection to an optional parallel port bracket. The parallel port is a standard printer port that supports Enhanced Parallel Port (EPP) and Extended Capabilities Parallel Port (ECP) mode.

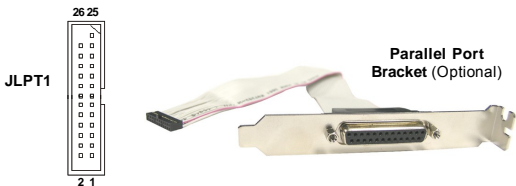

PIN	SIGNAL	PIN	SIGNAL	PIN	SIGNAL	PIN	SIGNAL
1	RSTB#	2	AFD#	15	PRND6	16	GND
3	PRND0	4	ERR#	17	PRND7	18	GND
5	PRND1	6	PINIT#	19	ACK#	20	GND
7	PRND2	8	LPT_SLIN#	21	BUSY	22	GND
9	PRND3	10	GND	23	PE	24	GND
11	PRND4	12	GND	25	SLCT	26	GND
13	PRND5	14	GND				

Front USB Connector: JUSB1/ JUSB2

The USB 2.0 pinheader is compliant with Intel® I/O Connectivity Design Guide. USB 2.0 technology increases data transfer rate up to a maximum throughput of 480Mbps, which is 40 times faster than USB 1.1, and is ideal for connecting high-speed USB interface peripherals such as **USB HDD, digital cameras, MP3 players, printers, modems and the like.**



Pin Definition

PIN	SIGNAL	PIN	SIGNAL
1	VCC	2	VCC
3	USB0-	4	USB1-
5	USB0+	6	USB1+
7	GND	8	GND
9	Key (no pin)	10	NC



Important

Note that the pins of VCC and GND must be connected correctly to avoid possible damage.

TV-Out Connector: JTV1

The mainboard provides a TV-Out connector.



JTV1 Pin Definition

Pin	Description	Pin	Description
1	GND	2	Y_L
3	C_L	4	COMP_L
5	GND	6	Key (no pin)

Display Matrix				
	CRT	HDMI	LVDS	TV OUT
CRT		X	V	X
HDMI	X		V	X
LVDS	V	V		V
TV OUT	X	X	V	

V : Support X : No Support

LVDS Flat Panel Connector: JLVDS1

The LVDS (Low Voltage Differential Signal) connector provides a digital interface typically used with flat panels. After connecting an LVDS interfaced flat panel to the JLVDS1, be sure to check the panel datasheet and set the J1 LVDS Power Selection Jumper to a proper voltage.

Display Matrix				
	CRT	HDMI	LVDS	TV OUT
CRT		X	V	X
HDMI	X		V	X
LVDS	V	V		V
TV OUT	X	X	V	

V : Support X : No Support

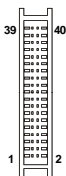

JLVDS1

SIGNAL	PIN	SIGNAL
+12V	2	+12V
+12V	4	+12V
GND	6	+12V
GND	8	VCC3/VCC5
LCD_VDD	10	LCD_VDD
LDDC_DATA	12	LDDC_CLK
LVDS_VDDEN	14	L_BKLTCTL
GND	16	L_BKLTEN
LA_DATA0	18	LA_DATA0#
LA_DATA1	20	LA_DATA1#
LA_DATA2	22	LA_DATA2#
LA_CLK	24	LA_CLK#
LA_DATA3	26	LA_DATA3#
GND	28	GND
LB_DATA0	30	LB_DATA0#
LB_DATA1	32	LB_DATA1#
LB_DATA2	34	LB_DATA2#
LB_CLK	36	LB_CLK#
LB_DATA3	38	LB_DATA3#
GND	40	GND

I2C Bus Connector: J4

The mainboard provides one I2C (also known as I²C) Bus connector for users to connect System Management Bus (SMBus) interface.



J4

Pin Definition

Pin	Signal
1	VCC5F
2	SMBCLK
3	GND
4	SMBDATA

Jumpers

COM Port Power Jumpers: J1, J2

These jumpers specify the operation voltage of the onboard serial ports.



Clear CMOS Jumper: JBAT1

There is a CMOS RAM onboard that has a power supply from external battery to keep the data of system configuration. With the CMOS RAM, the system can automatically boot OS every time it is turned on. If you want to clear the system configuration, set this jumper to clear data.

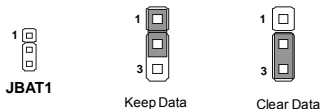

Important

You can clear CMOS by shorting 2-3 pin while the system is off. Then return to 1-2 pin position. Avoid clearing the CMOS while the system is on; it will damage the mainboard.

LVDS Power Selection Jumper: J3

Use this jumper to specify the operation voltage of the LVDS interfaced flat panel.



Slots

Mini PCI (Peripheral Component Interconnect) Express Slot

The CON1 is Mini PCI-E connector for wireless LAN, TV tuner, and Robson NAND Flash.



Mini PCI-E Slot

PCI (Peripheral Component Interconnect) Slot

The PCI slot supports LAN card, SCSI card, USB card, and other add-on cards that comply with PCI specifications.



32-bit PCI Slot

PCI Interrupt Request Routing

The IRQ, acronym of interrupt request line and pronounced I-R-Q, are hardware lines over which devices can send interrupt signals to the microprocessor. The PCI IRQ pins are typically connected to the PCI bus pins as follows:

DEVICE	IDSEL	INT A	INTB	INTC	INTD	REQ# / GNT#
32-bit PCI Slot	AD18	E	F	G	H	REQ#0 / GNT#0



Important

When adding or removing expansion cards, make sure that you unplug the power supply first. Meanwhile, read the documentation for the expansion card to configure any necessary hardware or software settings for the expansion card, such as jumpers, switches or BIOS configuration.

Chapter 3

System Resources

This chapter provides information on the following system resources:

1. Watch Dog Timer Setting (p. 3-2)
2. AMI POST Code (p. 3-3)
3. Resource List (p. 3-6)

Watch Dog Timer Setting

Software code

SIO_IDX equ 4EH

SIO_DTA equ 4FH

Timer equ 10; reset after 10 seconds

1. Enter configuration mode
mov dx,SIO_IDX
mov al,87h
out dx,al
out dx,al
2. Set to LDN 08
mov dx,SIO_IDX
mov al,07h
out dx,al
mov dx,SIO_DTA
mov al,08h
out dx,al
3. Set WatchDog Timer
mov dx,SIO_IDX
mov al,0f6h
out dx,al
mov dx,SIO_DTA
mov al,Timer
out dx,al
4. Exit configuration mode
mov dx,SIO_IDX
mov al,0AAh
out dx,al

AMI POST Code

Bootblock Initialization Code Checkpoints

The Bootblock initialization code sets up the chipset, memory and other components before system memory is available. The following table describes the type of checkpoints that may occur during the bootblock initialization portion of the BIOS:

Bootblock Initialization Code Checkpoint list

Checkpoint	Description
Before D1	Early chipset initialization is done. Early super I/O initialization is done including RTC and keyboard controller. NMI is disabled.
D1	Perform keyboard controller BAT test. Check if waking up from power management suspend state. Save power-on CPUID value in scratch CMOS.
D0	Go to flat mode with 4GB limit and GA20 enabled. Verify the bootblock checksum.
D2	Disable CACHE before memory detection. Execute full memory sizing module. Verify that flat mode is enabled.
D3	If memory sizing module not executed, start memory refresh and do memory sizing in Bootblock code. Do additional chipset initialization. Re-enable CACHE. Verify that flat mode is enabled.
D4	Test base 512KB memory. Adjust policies and cache first 8MB. Set stack.
D5	Bootblock code is copied from ROM to lower system memory and control is given to it. BIOS now executes out of RAM.
D6	Both key sequence and OEM specific method is checked to determine if BIOS recovery is forced. Main BIOS checksum is tested. If BIOS recovery is necessary, control flows to checkpoint E0.
D7	Restore CPUID value back into register. The Bootblock- Runtime interface module is moved to system memory and control is given to it. Determine whether to execute serial flash
D8	The Runtime module is uncompressed into memory. CPUID information is stored in memory.
D9	Store the Uncompressed pointer for future use in PMM. Copying Main BIOS into memory. Leaves all RAM below 1MB Read-Write including E000 and F000 shadow areas but closing SMRAM.
DA	Restore CPUID value back into register. Give control to BIOS POST (ExecutePOSTKernel.) See <i>POST Code Checkpoint list</i> for more information.

Post Code Checkpoints

The POST code checkpoints are the largest set of checkpoints during the BIOS preboot process. The following table describes the type of checkpoints that may occur during the POST portion of the BIOS:

Checkpoint	Description
03	Disable NMI, Parity, video for EGA, and DMA controllers. Initialize BIOS, POST, Runtime data area. Also initialize BIOS modules on POST entry and GPNV area. Initialize CMOS as mentioned in the Kernel Variable "Wcomsflags".
04	Check CMOS diagnostic byte to determine if battery power is OK and CMOS checksum is OK. Verify CMOS checksum manually by reading storage area. If the CMOS checksum is bad, update CMOS with power-on default values and clear passwords. Initialize status register A. Initialize data variables that are based on CMOS setup questions. Initialize both the 8259 compatible PICs in the system.
05	Initialize the interrupt controlling hardware (generally PIC) and interrupt vector table.
06	Do R/W test to CH-2 count reg. Initialize CH-0 as system timer. Install the POSTINT1Ch handler. Enable IRQ-0 in PIC for system timer interrupt. Traps INT1Ch vector to "POSTINT1ChHandlerBlock".
08	Initialize the CPU. The BAT test is being done on KBC. Program the keyboard controller command byte is being done after Auto detection of KB/MS using AMI KB-5.
0A	Initialize the 8042 compatible Key Board Controller.
0B	Detects the presence of PS/2 mouse.
0C	Detects the presence of keyboard in KBC port.
0E	Testing and initialization of different Input Devices. Also, update the Kernel Variables. Traps the INT09h vector, so that the POST INT09h handler gets control for IRQ1. Uncompress all available language, BIOS logo, and Silent logo modules.
13	Early POST initialization of chipset registers.
24	Uncompress and initialize any platform specific BIOS modules.
30	Initialize System Management Interrupt.
2A	Initialize different devices through DIM.
2C	Initialize different devices. Detects and initializes the video adapter installed in the system that have optional ROMs.
2E	Initialize all the output devices.
31	Allocate memory for ADM module and uncompress it. Give control to ADM module for initialization. Initialize language and font modules for ADM. Activate ADM module.
33	Initialize the silent boot module. Set the window for displaying test information.
37	Displaying sign-on message, CPU information, setup key message, and any OEM specific information.

Checkpoint	Description
38	Initializes different devices through DIM.
39	Initializes DMAC-1 & DMAC-2.
3A	Initializes RTC date/time.
3B	Test for total memory installed in the system. Also, Check for DEL or ESC keys to limit memory test. Display total memory in the system.
3C	Mid POST initialization of chipset registers.
40	Detect different devices (Parallel ports, serial ports, and coprocessor in CPU... etc.) successfully installed in the system and update the BDA, EBDA... etc.
50	Programming the memory hole or any kind of implementation that needs an adjustment in system RAM size if needed.
52	Updates CMOS memory size from memory found in memory test. Allocates memory for Extended BIOS Data Area from base memory.
60	Initializes NUM-LOCK status and programs the KBD typematic rate.
75	Initialize Int-13 and prepare for IPL detection.
78	Initializes IPL devices controlled by BIOS and option ROMs.
7A	Initializes remaining option ROMs.
7C	Generate and write contents of ESCD in NVRam.
84	Log errors encountered during POST.
85	Display errors to the user and gets the user response for error.
87	Execute BIOS setup if needed / requested.
8C	Late POST initialization for chipset registers.
8E	Program the peripheral parameters. Enable / Disable NMI as selected.
90	Late POST initialization of system management interrupt.
A0	Check boot password if installed.
A1	Clean-up work needed before booting to OS.
A2	Takes care of runtime image preparation for different BIOS modules Fill the free area in F000h segment with 0FFh. Initializes the Microsoft IRQ Routing Table. Prepares the runtime language module. Disables the system configuration display if needed.
A4	Initialize runtime language module.
A7	Displays the system configuration screen if enabled. Initialize the CPU's before boot, which includes the programming of the MTRR's.
A8	Prepare CPU for OS boot including final MTRR values.
A9	Wait for user input at config display if needed.
AA	Uninstall POST INT1Ch vector and INT09h vector. Deinitializes the ADM module.
AB	Prepare BBS for 19 boot.
AC	End of POST initialization of chipset registers.
B1	Save system contest for ACPI.
00	Passes control to OS Loader (typically INT19h).

Resource List

SB600 GPIO Config.

GPIO Pin	Type	Multiplexed	Power	Function
GPIO0	I/OD(3.3V)	NA	Main	NC
GPIO1	I/O(3.3V)	NA	Main	NC
GPIO2	I/O(3.3V)	NA	Main	NC
GPIO3	I/O(3.3V)	NA	Main	NC
GPIO4	I/O(3.3V)	NA	Main	NC
GPIO5	I/O(3.3V)	NA	Main	NC
GPIO6	I/OD(3.3V)	NA	Main	NC
GPIO7	I/O(3.3V)	NA	Main	NC
GPIO8	I/O(3.3V)	NA	Main	NC
GPIO9	I/O(3.3V)	NA	Main	IDE Cable Detect
GPIO10	I/O(3.3V)	NA	Main	NC
GPIO11	I/O(S5_3.3V)	SPI_DO	Standby	SPI_DO
GPIO12	I/O(S5_3.3V)	SPI_DI	Standby	SPI_DI
GPIO13	O(3.3V)	NA	Main	NC
GPIO14	I/O(3.3V)	NA	Main	NC
GPIO[15..30]	I/O(3.3V)	IDE_D [0..15]	Main	IDE_D [0..15]
GPIO31	I/O(S5_3.3V)	SPI_HOLD#	Standby	SPI_HOLD#
GPIO32	I/O(S5_3.3V)	SPI_CS#	Standby	SPI_CS#
GPIO33	I/O(3.3V)	INTE#	Main	INTE#
GPIO34	I/O(3.3V)	INTE#	Main	INTE#
GPIO35	I/O(3.3V)	INTE#	Main	INTE#
GPIO36	I/O(3.3V)	INTE#	Main	INTE#
GPIO37	I/O(3.3V)	NA	Main	NC
GPIO38	I/O(3.3V)	NA	Main	NC
GPIO39	I/O(3.3V)	AC_SDOUT	Main	AC_SDOUT#
GPIO40	I/O(3.3V)	NA	Main	NC
GPIO41	I/O(3.3V)	NA	Main	NC
GPIO42	I/O(S5_3.3V)	ACZ_SDIN0	Standby	ACZ_SDIN0#
GPIO43	I/O(S5_3.3V)	NA	Standby	NC
GPIO44	I/O(S5_3.3V)	NA	Standby	NC
GPIO45	I/O(S5_3.3V)	NA	Standby	NC
GPIO46	I/O(S5_3.3V)	NA	Standby	GPIO46
GPIO47	I/O(S5_3.3V)	SPI_CLK	Standby	SPI_CLK
GPIO48	I/O(3.3V)	NA	Main	AMP_GAN0
GPIO49	I/O(3.3V)	NA	Main	AMP_GAN1
GPIO50	I/O(3.3V)	NA	Main	AMP_EN
GPIO51	I/O(3.3V)	NA	Main	NC
GPIO52	I/O(3.3V)	NA	Main	NC
GPIO[53..60]	I/O(3.3V)	NA	Main	NC
GPIO61	I/O(3.3V)	NA	Main	NC
GPIO62	I/O(3.3V)	NA	Main	NC
GPIO63	I/O(3.3V)	NA	Main	NC
GPIO64	I/O(3.3V)	TALERT#	Main	TALERT#
GPIO65	I/O(3.3V)	BMREQ#	Main	BMREQ#
GPIO66	I/O(S5_3.3V)	NA	Standby	NC
GPIO67	OD(3.3V)	SATA_ACT#	Main	SATA_ACT#
GPIO68	I/O(3.3V)	NA	Main	NC
GPIO69	I/O(S5_3.3V)	NA	VBAT	NC
GPIO70	I/O(3.3V)	NA	Main	NC
GPIO71	I/O(3.3V)	NA	Main	NC
GPIO72	I/O(3.3V)	NA	Main	NC
GPIO73	I/O(3.3V)	NA	Main	NC

SB600 GPM Config.

GPM Pin	Type	Multiplexed	Power	Function
GPM#0	I/O(S5 3.3V)	USB_OC0#	Standby	USB OverCurrent
GPM#1	I/O(S5 3.3V)	USB_OC1#	Standby	USB OverCurrent
GPM#2	I/O(S5 3.3V)	NA	Standby	NC
GPM#3	I/O(S5 3.3V)	NA	Standby	NC
GPM#4	I/O(S5 3.3V)	NA	Standby	NC
GPM#5	I/O/OD(S5 3.3V)	NA	Standby	WLAN_PWRON
GPM#6	I/O(S5 3.3V)	NA	Standby	GPM6#
GPM#7	I/O(S5 3.3V)	SYS_RESET#	Standby	SYS_RESET#
GPM#8	I/O(S5 3.3V)	NA	Standby	NC
GPM#9	I/O(S5 3.3V)	NA	Standby	NC

SB600 EXTEVENT & GEVENT Config.

GEVENT Pin	Type	Multiplexed	Power	Function
EXTEVENT0#	I/O(S5 3.3V)	NA	Standby	NC
EXTEVENT1#	I/O(3.3V)	NA	Main	NC
GEVENT2#	I/O(S5 3.3V)	NA	Standby	NC
GEVENT3#	I/O(S5 3.3V)	LPC_PME#	Standby	LPC_PME#
GEVENT4#	I/O(S5 3.3V)	PCI_PME#	Standby	PCI_PME#
GEVENT5#	I/O(S5 3.3V)	NA	Standby	NC
GEVENT6#	I/O(S5 3.3V)	NA	Standby	NC
GEVENT7#	I/O(S5 3.3V)	NA	Standby	NC
GEVENT8#	I/O(S5 3.3V)	PCIE_WAKE#	Standby	PCIE_WAKE#

I/O Map

I/O Port	Description
0000-000F	DMA Controller 1
0020-0021	Interrupt Controller 1
002E-002F	SIO Port
0040-0043	ystem Timer
004E-004F	TPM Port
0060, 0064	Keyboard Controller
0070-0073	RTC and CMOS
0080-0090	DMA Controller Page Registers
0092	Port 92h
00A0-00A1	Interrupt Controller 2
00B2-00B3	APM register
00C0-00DF	DMA Controller 2
00F0-00FF	Numeric Data Processor
01F0-01F7	Primary IDE Controller
02F8-02FF	COM2
0376	Secondary IDE Controller
0378-037F	LPT1
03F6	Primary IDE Controller
03F8-03FF	COM1
0800-085F	ACPI I/O space
0B00-0B0F	SMBus I/O Space
0CF8-0CFF	PCI configuration Port

PCI Devices

PCI Device					
Device	Ven. ID	Dev. ID	Bus#	Dev#	Func#
ATi Host Bridge	1002	7910	00	00	00
ATi PCI-to-PCI Bridge	1002	7912	00	01	00
ATi PCI-to-PCI Bridge	1002	7914	00	04	00
ATi PCI-to-PCI Bridge	1002	7915	00	05	00
ATi PCI-to-PCI Bridge	1002	7916	00	06	00
ATi IDE Controller	1002	4380	00	12	00
ATi OHCI USB Controller	1002	4387	00	13	00
ATi OHCI USB Controller	1002	4388	00	13	01
ATi OHCI USB Controller	1002	4389	00	13	02
ATi OHCI USB Controller	1002	438A	00	13	03
ATi OHCI USB Controller	1002	438B	00	13	04
ATi Unknown Device	1002	4386	00	13	05
ATi SMBus	1002	4385	00	14	00
ATi IDE Controller	1002	438C	00	14	01
ATi Unknown Device	1002	4383	00	14	02
ATi ISA Bridge	1002	438D	00	14	03
ATi Subtractive Decode P2P Bridge	1002	4384	00	14	04
AMD Host Bridge	1022	1100	00	18	00

SMBus Resource Allocation

SMBus Resource Allocation		
Device	Address	Description
MS-6	0101 111X	ACPI Controller
DIMM Slot	1010 0000	SPD

ISA Interrupt Allocation

ISA Interrupt Allocation	
IRQ	Description
IRQ0	System Timer
IRQ1	Keyboard Controller
IRQ2	Cascade Interrupt
IRQ3	COM2
IRQ4	COM1
IRQ5	PCI Device
IRQ6	PCI Device
IRQ7	LPT1
IRQ8	RTC
IRQ9	ACPI Controller Interrupt
IRQ10	PCI Device
IRQ11	PCI Device
IRQ12	PS/2 Mouse
IRQ13	Numeric Data Processor
IRQ14	Primary IDE Controller
IRQ15	Secondary IDE Controller

ISA DMA Channel Allocation

DMA Channel	Description
Channel 0	Unassigned 8-bit channel
Channel 1	Unassigned 8-bit channel
Channel 2	Unassigned 8-bit channel
Channel 3	Unassigned 8-bit channel
Channel 4	Cascade channel
Channel 5	Unassigned 16-bit channel
Channel 6	Unassigned 16-bit channel
Channel 7	Unassigned 16-bit channel

Any advice or comments about our products and service, or anything we can help you with please don't hesitate to contact with us. We will do our best to support your products, projects and business.



Address: Global American, Inc.
17 Hampshire Drive
Hudson, NH 03051

Telephone: Toll Free (U.S. Only) 800-833-8999
(603)886-3900

FAX: (603)886-4545

Website: <http://www.globalamericaninc.com>
E-Mail: salesinfo@globalamericaninc.com

